

Hitachi AMS 2100/2300 Storage System Hardware Guide

FASTFIND LINKS

[Document conventions](#)

[Product version](#)

[Getting help](#)

[Table of Contents](#)

© 2008-2014 Hitachi, Ltd. All rights reserved.

No part of this publication may be reproduced or transmitted in any form or by any means, electronic or mechanical, including photocopying and recording, or stored in a database or retrieval system for any purpose without the express written permission of Hitachi, Ltd. and Hitachi Data Systems Corporation (hereinafter referred to as "Hitachi").

Hitachi, Ltd. and Hitachi Data Systems reserve the right to make changes to this document at any time without notice and assume no responsibility for its use. Hitachi, Ltd. and Hitachi Data Systems products and services can only be ordered under the terms and conditions of Hitachi Data Systems' applicable agreements.

All of the features described in this document may not be currently available. Refer to the most recent product announcement or contact your local Hitachi Data Systems sales office for information on feature and product availability.

Notice: Hitachi Data Systems products and services can be ordered only under the terms and conditions of Hitachi Data Systems' applicable agreements. The use of Hitachi Data Systems products is governed by the terms of your agreements with Hitachi Data Systems.

Hitachi is a registered trademark of Hitachi, Ltd. in the United States and other countries. Hitachi Data Systems is a registered trademark and service mark of Hitachi in the United States and other countries.

Systems is a registered trademark and service mark of Hitachi in the United States and other countries.

All other trademarks, service marks, and company names are properties of their respective owners.

Export authorization is required for the AMS 2000 Data At Rest Encryption

- Import/Use regulations may restrict export of the AMS2000 SED to certain countries
- China – AMS2000 is eligible for import but the License Key and SED may not be sent to China
- France – Import pending completion of registration formalities
- Hong Kong – Import pending completion of registration formalities
- Israel – Import pending completion of registration formalities
- Russia – Import pending completion of notification formalities
- Distribution Centers – IDC, EDC and ADC cleared for exports



Table of Contents

Preface	xi
Intended audience	xii
Product version	xii
Release notes and readme	xii
Document revision level	xii
Changes in this revision	xiii
Document organization	xiii
Document conventions	xiv
Convention for storage capacity values	xv
Accessing product documentation	xvi
Getting help	xxi
Comments	xxi
1 Introduction	1-1
Array overview	1-2
Control unit configurations	1-3
Power switch	1-4
AMS 2100 base unit	1-6
AMS 2300 base unit	1-7
Expansion unit	1-9
High capacity expansion unit	1-10
Features and benefits	1-11
Supported host operating systems	1-11
High data availability	1-11
Connectivity	1-11
Fibre channel interface	1-11
iSCSI interface	1-13
Scalability	1-15
Fibre channel interface	1-18
iSCSI interface	1-19
High capacity cache	1-19
Cache management	1-19

Cache specifications	1-20
Performance reporting and monitoring	1-20
Reliability, availability, and serviceability	1-21
Dynamic load balance	1-21
High reliability	1-21
Spare disks	1-21
Replacing an active failed disk drive	1-21
Redundant power supplies	1-21
RAID implementations	1-22
Open systems features and functions	1-23
Open systems middleware	1-23
Logical unit mapping	1-23
Data management features and functions	1-24
Copy solution features and functions	1-26
Performance management features and functions	1-26
Failure monitoring features and functions	1-27
E-mail alert function	1-27
Power saving features and functions	1-27
Email alert notification	1-28
Cooperative function with VMware	1-28
Long term array storage	1-29
2 Functional and operational characteristics	2-1
Overview of the AMS 2100/2300 storage system	2-2
Architecture and components	2-2
AMS 2100 configuration architecture	2-2
AMS 2300 configuration architecture	2-4
Expansion unit architecture	2-5
Modular 2U SAS expansion unit RKAKS architecture	2-6
High-density expansion unit architecture	2-7
Array specifications	2-8
Fibre channel interface	2-10
iSCSI interface	2-11
Setting iSCSI information	2-11
Required parts	2-12
Optional parts	2-14
Accessory parts	2-18
3 Getting started	3-1
Task roadmap	3-2
4 Hardware components	4-1
The base unit	4-2
Base unit front panel	4-2
Disk drives	4-3

Disk drive configurations	4-3
Disk drive status LEDs	4-3
Base unit status LEDs.	4-4
Front panel	4-4
.	4-5
Rear panel	4-5
Cache backup batteries	4-5
Switch panel	4-7
Base unit rear panel.	4-8
Overview	4-8
Base unit power supplies	4-9
Power supply status.	4-9
Power receptacles	4-9
Safety lock	4-10
Control units	4-10
AMS 2100 Fibre channel control unit	4-11
AMS 2100 Rev1 Fibre channel control unit RKS.	4-12
AMS 2100 Rev2 Fibre channel control unit RKES.	4-13
AMS 2300 Fibre Channel control unit	4-15
AMS 2300 Rev2 Fibre channel control unit RKM	4-16
AMS 2300 Rev2 Fibre channel control unit RKEM	4-17
AMS 2100/2300 iSCSI control unit.	4-19
Fibre channel host connectors.	4-22
10/100 Ethernet management port	4-23
Standard expansion unit.	4-25
Expansion unit (RKAK) front panel.	4-25
Disk drives	4-26
Disk drive configurations	4-26
Disk drive status LEDs	4-27
Expansion unit status LEDs.	4-28
Expansion unit rear panel.	4-29
Expansion unit power supply	4-30
Power supply status.	4-30
Power receptacles	4-30
Safety lock	4-31
ENC unit RKAK	4-32
Modular 2U SAS expansion unit	4-33
Modular 2U SAS expansion unit front panel	4-33
Modular 2U SAS expansion unit disk drive LEDs	4-34
Modular 2U SAS expansion unit power unit	4-34
Power supply status.	4-34
Modular 2U SAS expansion unit ENC unit	4-35
High-density expansion unit	4-36
High-density expansion unit front view	4-36
High-density expansion unit front panel	4-37
High-density expansion unit status LEDs	4-37
High-density expansion unit rear panel	4-38

High-density expansion unit power supply	4-39
High-density expansion unit ENC connectors	4-41
High-density expansion unit top view	4-42
Disk drive configurations	4-43
Disk drive status LEDs	4-43
High-density expansion unit ENC card	4-45
5 Installation	5-1
Chapter overview and task list	5-2
Safety considerations	5-2
Personal safety	5-2
Electrical safety guidelines	5-3
Handling of cables on the floor	5-4
Handling of under-floor cables	5-4
Equipment safety	5-4
Warning labels	5-5
Warning and safety labels (base unit)	5-5
Warning and safety labels (expansion unit)	5-6
Warning and safety labels (modular 2U SAS expansion unit)	5-7
Warning and safety labels (high-density expansion unit)	5-8
Disk drives	5-9
Battery unit	5-10
Power supply	5-10
Control unit	5-12
Cache memory	5-13
Interface board	5-13
Host connector	5-14
ENC unit	5-15
ENC cable	5-16
Cable holder	5-17
Preinstallation requirements	5-18
Site considerations	5-18
User-provided items	5-18
Installation site	5-18
Floor load rating	5-19
Installation area and service clearance	5-19
Notes about installation	5-19
Installation configurations	5-20
Minimum configurations	5-22
Maximum configurations	5-23
Installing an AMS 2100/2300	5-24
Installation road map	5-24
Unpacking an array	5-24
Checking the contents of the package	5-27
Removing the front bezel	5-28
Removing the front bezel of the modular 2U SAS expansion unit	5-30
Mounting the array in a rack	5-30

Attaching an EMI gasket	5-30
Mounting the array	5-33
Fastening the array to the rack	5-34
Connecting cables	5-35
Connecting a LAN cable	5-48
Connecting power cables	5-49
Turning the array ON	5-53
Adding a disk drive	5-53
Task overview	5-53
Installing a disk drive	5-54
Attaching a front bezel	5-55
Attaching a modular 2U SAS extension unit front bezel	5-56
Installing Storage Navigator Modular 2	5-57
6 Power On/Off procedures	6-1
Task list	6-2
Prerequisites	6-2
Restarting a base unit	6-2
Storage system power on	6-3
Base unit	6-3
Power on self test	6-4
Expansion units and high-density expansion units	6-5
Storage system power off	6-5
Base unit	6-5
Expansion units	6-5
Recovering from a power outage	6-6
7 Configuration	7-1
Configuration tasks	7-2
Prerequisites	7-2
User supplied items	7-2
Supported network standards	7-3
Precautions when using the IPv6 protocol	7-4
Navigator 2 IPv6 support	7-4
IPv6 Link local address	7-5
Setting the IPv6 address	7-5
Incorrect router advertisement	7-5
Temporary address	7-6
Connection method	7-6
Communication modes	7-7
Configuring an AMS 2100/2300	7-8
Prerequisites	7-8
Configuration roadmap	7-9

Introducing Navigator 2	7-9
Navigator 2 features	7-10
Storage features	7-11
Installing Navigator 2	7-12
Changing the storage management PC IP address	7-12
Navigator 2 Installation procedure	7-13
Installing Java	7-13
Clients running Microsoft Windows	7-14
Clients running Solaris or Linux	7-15
Installation problems	7-15
Starting Navigator 2	7-15
Managing storage	7-18
First time storage configuration - required tasks	7-18
Adding arrays to Navigator 2	7-18
Managing a specific array	7-21
Initial array setup	7-22
Restoring the management console	7-28
Reregistering the array	7-29
Registering the array on the support website	7-31
Cautionary note about system construction	7-31
Fabric Switch Connection Configurations	7-34
A note on deleting the RAID group expansion instruction after executing the RAID Group expansion instruction	7-34
Additional storage configuration - optional tasks	7-35
Checking the array status	7-36
Managing resources	7-36
Managing replication	7-39
Local replication	7-40
Remote replication	7-40
Using the LUN manager	7-41
Performance tuning in small-scale configurations	7-42
Using SSL	7-48
Launching Navigator 2	7-48
Navigator 2 security settings	7-48
Changing the server certificate and private key	7-49
Updating the server certificate and private key	7-51
Changing the Navigator 2 web server configuration	7-52
Changing the Navigator 2 Java applet configuration	7-52
Setting the day and time	7-52
Edit Date & Time	7-54
Edit Time Zone & NTP	7-54
Refresh Information	7-55
Other storage management operations	7-55
Uninstalling Navigator 2	7-56

8	Troubleshooting	8-1
	Getting help	8-2
	Troubleshooting tables.	8-2
	Troubleshooting flowcharts.	8-9
	Navigator 2 does not start	8-9
	Navigator 2 cannot connect to an array	8-10
	Recovering from failures	8-11
	Troubleshooting based on LED indications	8-13
	The power LED does not turn on.	8-14
	The power LED has turned off	8-15
	Ready LED does not turn on	8-15
	Alarm LED has turned on	8-16
	Warning LED has turned on or blinks.	8-16
9	Upgrading the hardware	9-1
	Prerequisites	9-2
	Adding a disk drive	9-3
	Locations and numbers of disk drives	9-3
	Locations of disk drives	9-4
	If no vacant slots are available	9-4
	Installation procedure	9-5
	Expanding storage capacity	9-7
	Recognizing a new logical unit	9-8
	Adding an expansion unit	9-9
	Prerequisites	9-9
	Restrictions	9-9
	Specifications	9-9
	Adding an expansion unit	9-10
	Adding an expansion unit with the array power turned on	9-10
	Adding an expansion unit with the array power turned off	9-11
	Connection and recognition of the expansion unit	9-12
10	Upgrading the firmware	10-1
	Overview	10-2
	Prerequisites	10-2
	Upgrading the firmware	10-2
	Upgrading the software	10-5
11	Connection configuration restrictions.	11-1
	Connection of Additional Chassis.	11-2
	Correct installation.	11-2
	Incorrect installation	11-2

A	Specifications	A-1
	Mechanical specifications	A-2
	Electrical specifications	A-2
	Environmental specifications.	A-3
	Ethernet specifications.	A-3
	Cache specifications	A-4
B	Regulatory information	B-1
	Regulatory compliance.	B-2
	US FCC Notice and/or Declaration of Conformity	B-3
	Canadian DoC Notice.	B-3
	European Declaration of Conformity	B-4
	Notice of export controls	B-4
	China RoHS	B-4
	Hazardous and toxic substances	B-4
	Disposal	B-5
	Recycling	B-5

Glossary

Index



Preface

Congratulations on purchasing a new Hitachi AMS 2100/2300 Storage System.

This guide will assist you in installing, configuring, and maintaining your Hitachi AMS 2100/2300.

This preface includes the following information:

- [Intended audience](#)
- [Product version](#)
- [Release notes and readme](#)
- [Document revision level](#)
- [Changes in this revision](#)
- [Document organization](#)
- [Document conventions](#)
- [Convention for storage capacity values](#)
- [Accessing product documentation](#)
- [Getting help](#)

Intended audience

This document is intended for system administrators, Hitachi Data Systems representatives, and Authorized Service Providers who install, configure, and operate Hitachi Adaptable Modular System (AMS) 2000 Family storage systems.

Product version

This document applies to Hitachi AMS 2000 Family firmware version 08C3/R or later.

Release notes and readme

Read the release notes and readme file before installing and using this product. They may contain requirements or restrictions that are not fully described in this document and updates or corrections to this document.

Document revision level

This section provides a history of the revision changes to this document.

Revision	Date	Description
MK-97DF8010-00	October 2008	Initial Release
MK-97DF8010-01	November 2008	Revision 1, supersedes and replaces MK-97DF8010-00.
MK-97DF8010-02	February 2009	Revision 2, supersedes and replaces MK-97DF8010-01.
MK-97DF8010-03	April 2009	Revision 3, supersedes and replaces MK-97DF8010-02.
MK-97DF8010-04	May 2009	Revision 4, supersedes and replaces MK-97DF8010-03.
MK-97DF8010-05	June 2009	Revision 5, supersedes and replaces MK-97DF8010-04.
MK-97DF8010-06	July 2009	Revision 6, supersedes and replaces MK-97DF8010-05.
MK-97DF8010-07	August 2009	Revision 7, supersedes and replaces MK-97DF8010-06.
MK-97DF8010-08	November 2009	Revision 8, supersedes and replaces MK-97DF8010-07.
MK-97DF8010-09	December 2009	Revision 9, supersedes and replaces MK-97DF8010-08.
MK-97DF8010-10	January 2010	Revision 10, supersedes and replaces MK-97DF8010-09.
MK-97DF8010-11	April 2010	Revision 11, supersedes and replaces MK-97DF8010-10.
MK-97DF8010-12	August 2010	Revision 12, supersedes and replaces MK-97DF8010-11.
MK-97DF8010-13	November 2010	Revision 13, supersedes and replaces MK-97DF8010-12.
MK-97DF8010-14	December 2010	Revision 14, supersedes and replaces MK-97DF8010-13.
MK-97DF8010-15	February 2011	Revision 15, supersedes and replaces MK-97DF8010-14.
MK-97DF8010-16	May 2011	Revision 16, supersedes and replaces MK-97DF8010-15.
MK-97DF8010-17	July 2011	Revision 17, supersedes and replaces MK-97DF8010-16.
MK-97DF8010-18	August 2011	Revision 18, supersedes and replaces MK-97DF8010-17.
MK-97DF8010-19	September 2011	Revision 19, supersedes and replaces MK-97DF8010-18.
MK-97DF8010-20	December 2012	Revision 20, supersedes and replaces MK-97DF8010-19.
MK-97DF8010-21	January 2013	Revision 21, supersedes and replaces MK-97DF8010-20.

Revision	Date	Description
MK-97DF8010-22	July 2013	Revision 22, supersedes and replaces MK-97DF8010-21
MK-97DF8010-23	December 2013	Revision 23, supersedes and replaces MK-97DF8010-22
MK-97DF8010-24	April 2014	Revision 24, supersedes and replaces MK-97DF8010-23
MK-97DF8010-25	August 2014	Revision 25, supersedes and replaces MK-97DF8010-24

Changes in this revision

- Under [E-mail alert function on page 1-27](#), added text about the email settings return to default settings following a power outage or loss of battery power.
- Added the new section [Setting the day and time on page 7-52](#).

Document organization









Thumbnail descriptions of the chapters are provided in the following table. Click the [chapter title](#) in the first column to go to that chapter. The first page of every chapter or appendix contains links to the contents.

Chapter/Appendix Title	Description
Chapter 1, Introduction	This chapter provides a brief overview of the AMS 2100/2300.
Chapter 2, Functional and operational characteristics	This chapter describes the basic features of the AMS 2100/2300 models.
Chapter 3, Getting started	This chapter provides an overview of the tasks to install and configure an AMS 2100/2300 disk array.
Chapter 4, Hardware components	This chapter describes the hardware components of an AMS 2100/2300.
Chapter 5, Installation	This chapter explains the steps to prepare a site to install an AMS 2100/2300 array and provides instructions to install the array.
Chapter 6, Power On/Off procedures	This chapter provides the procedures to apply power to and remove power from an AMS 2100/2300 disk array.
Chapter 7, Configuration	This chapter describes how to configure an AMS 2100/2300.
Chapter 8, Troubleshooting	This chapter provides information to help you identify and resolve problems in the event that you encounter a problem with an AMS 2100/2300.
Chapter 9, Upgrading the hardware	This chapter describes procedures for adding optional components and additional units to the AMS 2100/2300
Chapter 10, Upgrading the firmware	This chapter provides the procedures to Upgrade the firmware on the AMS 2100/2300.
Appendix A, Specifications	This appendix provides the mechanical, electrical, environmental, and other specifications for the AMS 2100/2300 systems. Complete specifications are contained in the <i>Hitachi AMS 2000 Family Storage System Reference Guide</i> .

Chapter/Appendix Title	Description
Appendix B, Regulatory information	This appendix provides information about the regulatory and compliance rules that govern the installation and operation of the AMS 2100/2300.

Document conventions

This document uses the following symbols to draw attention to important safety and operational information.

Symbol	Meaning	Description
	Tip	Tips provide helpful information, guidelines, or suggestions for performing tasks more effectively.
	Note	Notes emphasize or supplement important points of the main text.
	Caution	Cautions indicate that failure to take a specified action could result in damage to the software or hardware.
	WARNING	Warnings indicate that failure to take a specified action could result in loss of data or serious damage to the hardware.
	DANGER	The Danger symbol warns users of possible injury or death if instructions are not followed.
	ELECTRIC SHOCK HAZARD!	This symbol warns users of electric shock hazard. Failure to take appropriate precautions such as not opening or touching hazardous areas of the equipment could result in injury or death.
	Electrostatic Sensitive	The ESD symbol warns users that the equipment is sensitive to electrostatic discharge (ESD) and could be damaged if users do not take appropriate precautions such as using a grounded wrist strap when touching or handling the equipment.
	Burn Hazard	HOT SURFACE! Turn off power and allow to cool before touching.
	Sharp Edges or Corners	WARNING! Sharp edges or corners. Avoid touching or wear gloves

The following typographic conventions are used in this document.

Convention	Description
Bold	Indicates text on a window, other than the window title, including menus, menu options, buttons, fields, and labels. Example: Click OK.
<i>Italic</i>	Indicates a variable, which is a placeholder for actual text provided by the user or system. Example: copy source-file target-file. Note: Angled brackets (< >) are also used to indicate variables.

Convention	Description
screen text	Indicates text that is displayed on screen or entered by the user. Example: # pairdisplay -g oradb
< > angled brackets	Indicates a variable, which is a placeholder for actual text provided by the user or system. Example: # pairdisplay -g <group> Note: Italic font is also used to indicate variables.
[] square brackets	Indicates optional values. Example: [a b] indicates that you can choose a, b, or nothing.
{ } braces	Indicates required or expected values. Example: { a b } indicates that you must choose either a or b.
vertical bar	Indicates that you have a choice between two or more options or arguments. Examples: [a b] indicates that you can choose a, b, or nothing. { a b } indicates that you must choose either a or b.
<u>underline</u>	Indicates the default value. Example: [a b]

Convention for storage capacity values

Physical storage capacity values (e.g., disk drive capacity) are calculated based on the following values:

Physical capacity unit	Value
1 KB	1,000 bytes
1 MB	1,000 KB or 1,000 ² bytes
1 GB	1,000 MB or 1,000 ³ bytes
1 TB	1,000 GB or 1,000 ⁴ bytes
1 PB	1,000 TB or 1,000 ⁵ bytes
1 EB	1,000 PB or 1,000 ⁶ bytes

Logical storage capacity values (e.g., logical device capacity) are calculated based on the following values:

Logical capacity unit	Value
1 block	512 bytes
1 KB	1,024 (2 ¹⁰) bytes
1 MB	1,024 KB or 1024 ² bytes
1 GB	1,024 MB or 1024 ³ bytes
1 TB	1,024 GB or 1024 ⁴ bytes
1 PB	1,024 TB or 1024 ⁵ bytes
1 EB	1,024 PB or 1024 ⁶ bytes

Accessing product documentation

The AMS 2000 Family user documentation is available on the Hitachi Data Systems Portal: <https://portal.hds.com>. Please check this site for the most current documentation, including important updates that may have been made after the release of the product.

This documentation set consists of the following documents.

Release notes

- Adaptable Modular Storage System Release Notes
- Storage Navigator Modular 2 Release Notes



Please read the release notes before installing and/or using this product. They may contain requirements and/or restrictions not fully described in this document, along with updates and corrections to this document.

Installation and getting started

The following documents provide instructions for installing an AMS 2000 Family storage system. They include rack information, safety information, site-preparation instructions, getting-started guides for experienced users, and host connectivity information. The symbol  identifies documents that contain initial configuration information about Hitachi AMS 2000 Family storage systems.

 **AMS2100/2300 Getting Started Guide**, MK-98DF8152

Provides quick-start instructions for getting an AMS 2100 or AMS 2300 storage system up and running as quickly as possible.

 **AMS2500 Getting Started Guide**, MK-97DF8032

Provides quick-start instructions for getting an AMS 2500 storage system up and running as quickly as possible.

AMS 2000 Family Site Preparation Guide, MK-98DF8149

Contains site planning and pre-installation information for AMS 2000 Family storage systems, expansion units, and high-density expansion units. This document also covers safety precautions, rack information, and product specifications.

AMS 2000 Family Fibre Channel Host Installation Guide,
MK-08DF8189

Describes how to prepare Hitachi AMS 2000 Family Fibre Channel storage systems for use with host servers running supported operating systems.

AMS 2000 Family iSCSI Host Installation Guide, MK-08DF8188

Describes how to prepare Hitachi AMS 2000 Family iSCSI storage systems for use with host servers running supported operating systems.

Storage and replication features

The following documents describe how to use Storage Navigator Modular 2 (Navigator 2) to perform storage and replication activities.

Storage Navigator 2 Advanced Settings User's Guide, MK-97DF8039

Contains advanced information about launching and using Navigator 2 in various operating systems, IP addresses and port numbers, server certificates and private keys, boot and restore options, outputting configuration information to a file, and collecting diagnostic information.

Storage Navigator Modular 2 User's Guide, MK-99DF8208

Describes how to use Navigator 2 to configure and manage storage on an AMS 2000 Family storage system.

AMS 2000 Family Dynamic Provisioning Configuration Guide, MK-09DF8201

Describes how to use virtual storage capabilities to simplify storage additions and administration.

Storage Navigator 2 Storage Features Reference Guide for AMS, MK-97DF8148

Contains concepts, preparation, and specifications for Account Authentication, Audit Logging, Cache Partition Manager, Cache Residency Manager, Data Retention Utility, LUN Manager, Performance Monitor, SNMP Agent, and Modular Volume Migration.

AMS 2000 Family Copy-on-write SnapShot User Guide, MK-97DF8124

Describes how to create point-in-time copies of data volumes in AMS 2100, AMS 2300, and AMS 2500 storage systems, without impacting host service and performance levels. Snapshot copies are fully read/write compatible with other hosts and can be used for rapid data restores, application testing and development, data mining and warehousing, and nondisruptive backup and maintenance procedures.

AMS 2000 Family ShadowImage In-system Replication User Guide, MK-97DF8129

Describes how to perform high-speed nondisruptive local mirroring to create a copy of mission-critical data in AMS 2100, AMS 2300, and AMS 2500 storage systems. ShadowImage keeps data RAID-protected and fully recoverable, without affecting service or performance levels. Replicated data volumes can be split from host applications and used for

system backups, application testing, and data mining applications while business continues to operate at full capacity.

AMS 2000 Family TrueCopy Remote Replication User Guide,
MK-97DF8052

Describes how to create and maintain multiple duplicate copies of user data across multiple AMS 2000 Family storage systems to enhance your disaster recovery strategy.

AMS 2000 Family TrueCopy Extended Distance User Guide,
MK-97DF8054

Describes how to perform bi-directional remote data protection that copies data over any distance without interrupting applications, and provides failover and recovery capabilities.

AMS 2000 Data Retention Utility User's Guide, MK-97DF8019

Describes how to lock disk volumes as read-only for a certain period of time to ensure authorized-only access and facilitate immutable, tamper-proof record retention for storage-compliant environments. After data is written, it can be retrieved and read only by authorized applications or users, and cannot be changed or deleted during the specified retention period.

Storage Navigator Modular 2 online help

Provides topic and context-sensitive help information accessed through the Navigator 2 software.

Hardware maintenance and operation

The following documents describe how to operate, maintain, and administer an AMS 2000 Family storage system. They also provide a wide range of technical information and specifications for the AMS 2000 Family storage systems. The symbol  identifies documents that contain initial configuration information about Hitachi AMS 2000 Family storage systems.

 **AMS 2100/2300 Storage System Hardware Guide**, MK-97DF8010 — this document

Provides detailed information about installing, configuring, and maintaining an AMS 2100/2300 storage system.

 **AMS 2500 Storage System Hardware Guide**, MK-97DF8007

Provides detailed information about installing, configuring, and maintaining an AMS 2500 storage system.

 **AMS 2000 Family Storage System Reference Guide**, MK-97DF8008

Contains specifications and technical information about power cables, system parameters, interfaces, logical blocks, RAID levels and configurations, and regulatory information about AMS 2100, AMS 2300, and AMS 2500 storage systems. This document also contains remote adapter specifications and regulatory information.

AMS 2000 Family Storage System Service and Upgrade Guide, MK-97DF8009

Provides information about servicing and upgrading AMS 2100, AMS 2300, and AMS 2500 storage systems.

AMS 2000 Family Power Savings User Guide, MK-97DF8045

Describes how to spin down volumes in selected RAID groups when they are not being accessed by business applications to decrease energy consumption and significantly reduce the cost of storing and delivering information.

Command and Control (CCI)

The following documents describe how to install the Hitachi AMS 2000 Family Command Control Interface (CCI) and use it to perform TrueCopy and ShadowImage operations.

AMS 2000 Family Command Control Interface (CCI) Installation Guide, MK-97DF8122

Describes how to install CCI software on open-system hosts.

AMS 2000 Family Command Control Interface (CCI) Reference Guide, MK-97DF8121

Contains reference, troubleshooting, and maintenance information related to CCI operations on AMS 2100, AMS 2300, and AMS 2500 storage systems.

AMS 2000 Family Command Control Interface (CCI) User's Guide, MK-97DF8123

Describes how to use CCI to perform TrueCopy and ShadowImage operations on AMS 2100, AMS 2300, and AMS 2500 storage systems.

Command Line Interface (CLI)

The following documents describe how to use Hitachi Storage Navigator Modular 2 to perform management and replication activities from a command line.

Storage Navigator Modular 2 Command Line Interface (CLI) Unified Reference Guide, MK-97DF8089

Describes how to interact with all Navigator 2 bundled and optional software modules by typing commands at a command line.

Storage Navigator 2 Command Line Interface Replication Reference Guide for AMS, MK-97DF8153

Describes how to interact with Navigator 2 to perform replication activities by typing commands at a command line.

Dynamic Replicator documentation

The following documents describe how to install, configure, and use Hitachi Dynamic Replicator to provide AMS Family storage systems with continuous data protection, remote replication, and application failover in a single, easy-to-deploy and manage platform.

Hitachi Dynamic Replicator - Scout Release Notes, RN-99DF8211

Hitachi Dynamic Replicator - Scout Host Upgrade Guide,
MK-99DF8267

Hitachi Dynamic Replicator - Scout Host User Guide
MK-99DF8266

Hitachi Dynamic Replicator - Scout Installation and Configuration Guide, MK-98DF8213

Hitachi Dynamic Replicator - Scout Quick Install/Upgrade Guide,
MK-98DF8222

Getting help

If you need to contact the Hitachi Data Systems support center, please provide as much information about the problem as possible, including:

- The circumstances surrounding the error or failure.
- The exact content of any messages displayed on the host systems.
- The exact content of any messages displayed on Storage Navigator Modular 2.
- The Storage Navigator Modular 2 configuration information. This information is used by service personnel for troubleshooting purposes.

The Hitachi Data Systems customer support staff is available 24 hours a day, seven days a week. If you need technical support, please log on to the Hitachi Data Systems Portal for contact information: <https://portal.hds.com>

Comments

Please send us your comments on this document: doc.comments@hds.com. Include the document title, number, and revision, and refer to specific section and paragraph whenever possible.

Thank you! (All comments become the property of Hitachi Data Systems.)

Introduction

This chapter provides an overview of the Hitachi AMS 2100/2300 Storage System. It covers the following key topics:

- ❑ [Array overview](#)
- ❑ [Features and benefits](#)
- ❑ [High capacity cache](#)
- ❑ [Performance reporting and monitoring](#)
- ❑ [Reliability, availability, and serviceability](#)
- ❑ [RAID implementations](#)
- ❑ [Open systems features and functions](#)
- ❑ [Data management features and functions](#)
- ❑ [Copy solution features and functions](#)
- ❑ [Performance management features and functions](#)
- ❑ [Failure monitoring features and functions](#)
- ❑ [Power saving features and functions](#)
- ❑ [Email alert notification](#)
- ❑ [Long term array storage](#)

Array overview

The AMS 2100/2300 storage system consists of three main components:

- A **base unit**, which includes two redundant power supplies, two redundant controllers, two cache backup batteries, and from four to 15 disk drives. The base unit provides data storage, as well as connection, control, and management of the array system. There are two base unit models:
 - AMS 2100 (Hitachi factory designation RKS)
 - AMS 2300 (Hitachi factory designation RKM)
- Optional **expansion units**. For the AMS 2100, one to seven expansion units, and for the AMS 2300, one to 15 expansion units. An expansion unit provides additional storage space and can connect the base unit to additional expansion units or high-density expansion units. The same expansion unit is used with both base unit models. The factory designation for the standard expansion unit is RKAK.

An expansion unit contains two redundant power supplies, two ENC interface units, and from two to 15 disk drives.

- Optional **modular 2U SAS expansion units**. For the AMS 2100 and the AMS 2300, this unit can install a maximum of 24 disk drives. An expansion unit provides additional storage space and can connect the base unit to additional expansion units or high-density expansion units. The same expansion unit is used with both base unit models. The factory designation for the modular expansion unit is RKAKS.

An expansion unit contains two redundant power supplies, two ENC interface units, and from two to 24 disk drives.

- Optional **high-density expansion units**. For the AMS 2100, one high-density expansion unit, and for the AMS 2300, one to four high-density expansion units. A high-density expansion unit provides additional storage space and can connect the base unit to additional expansion units or high-density expansion units. The same high-density expansion unit is used with both base unit models. The factory designation for the high-density expansion unit is RKAKX.

A high-density expansion unit contains two independent storage sections. Each section contains two redundant power supplies, two redundant ENC control units, and from four to 24 disk drives. The maximum number of drives that can be installed in a high-density unit is 48.

Table 2-1. Array components

Type	Factory name	Component name
2100	RKS	Base unit
	RKES	Rev2 base unit
2300	RKM	Base unit
	RKEM	Rev2 base unit
Expansion Units	RKAK	Standard
	RKAKS	Modular 2U SAS
	RKAKX	High density



NOTE: See [Scalability on page 1-15](#) for details about combinations of expansion units and high-density expansion units.

Control unit configurations

The Hitachi Data Systems AMS 2100/2300 base units support the following controller configurations. Numbers are total per base unit.

Table 1-1: AMS 2100/2300 Control Unit Configurations

Base Unit	Host Interface	Number of Ports (total)	Cache
AMS 2100	Fibre Channel	4 Fibre Channel	4 GB
			8 GB
	iSCSI	4 iSCSI	4 GB
			8 GB
AMS 2300	Fibre Channel	8 Fibre Channel	8 GB
			16 GB
	iSCSI	4 iSCSI	8 GB
			16 GB

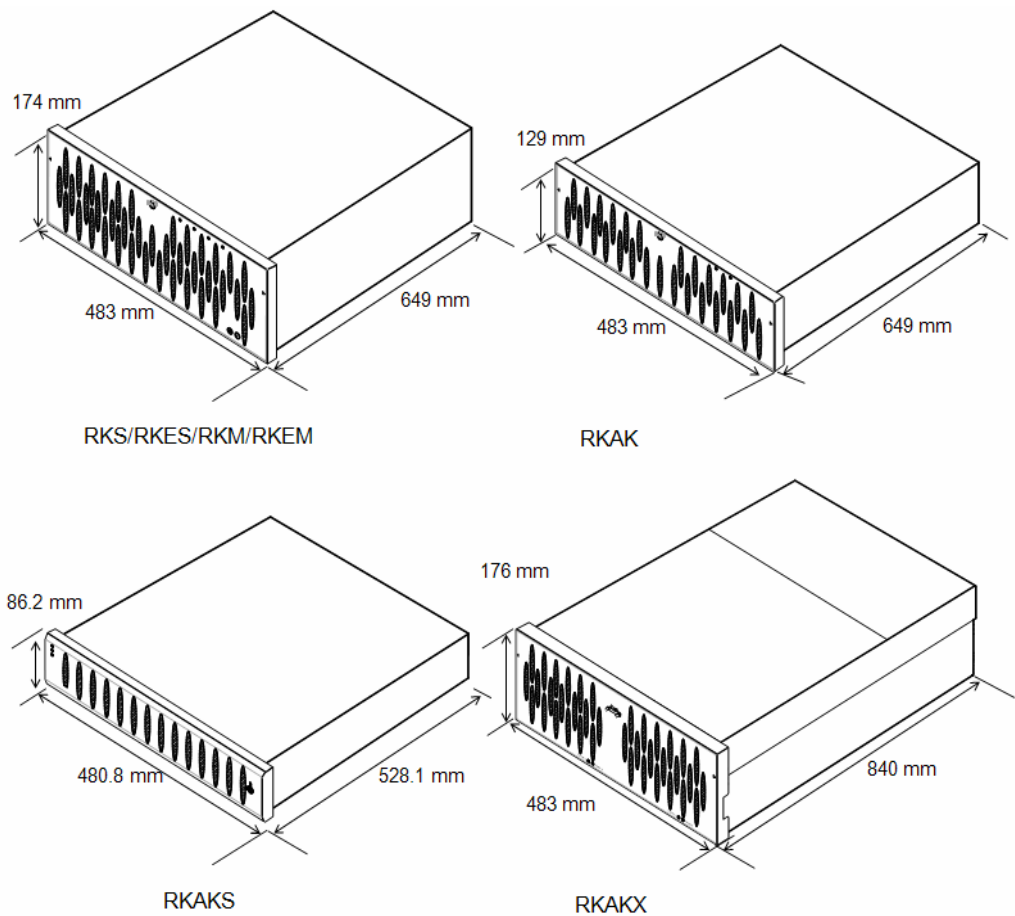

Figure 1-1: Base and Expansion units

Figure shows a basic illustration of a base unit, two expansion units, and a high-density expansion unit. They are all described briefly in this chapter and in detail in [Chapter 4, Hardware components](#).

The front of the AMS 2100 and AMS 2300 base units are identical. Light-Emitting Diode (LED) indicators show the unit's power, ready, warning, and alarm status.

Power switch

The Power switch for turning the controllers and drives in a base unit is also located on the front of the unit. Facing the front of the base unit, this switch is located at the lower right corner. Pressing on the right button turns the power on. Pressing on the left button turns the power off.

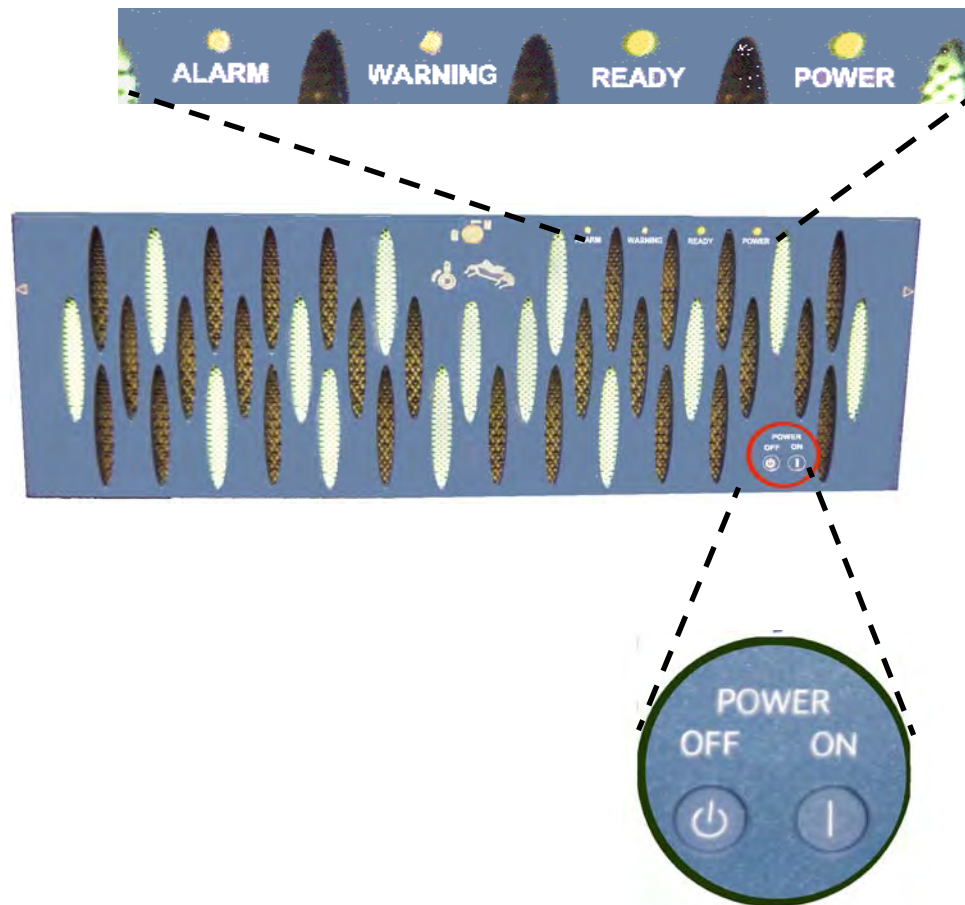

Figure 1-2: Front View of base unit



NOTE: The power ON/OFF buttons on the front bezel actuate the Main Switch on the front of the base unit (behind the front bezel). The Main Switch is actually a standby switch and controls power to all components in the base unit except the power supplies. The power supplies do not have a power switch and turn on as soon as the power cables are connected to them. They can deliver power to the rest of the unit after successful completion of their power on self test (POST). See [Chapter 4, Hardware components](#) and [Chapter 6, Power On/Off procedures](#) or details.

When the power switch is toggled to the OFF position, power is still applied to the power supplies. To completely remove the power from the unit, remove both power cables from the unit or disconnect them from the power source.

AMS 2100 base unit

The Hitachi AMS 2100 storage system (model RKS) (hereafter referred to as AMS 2100) includes a base unit and from 0 to 7 expansion units or from from 0 to 3 high-density expansion units.

- The base unit contains from 4 to 15 SAS and/or SATA disk drives, two redundant controllers, two redundant power supplies, and two cache battery backup units.
- Each base unit contains two controllers that manage all functions of the array and connect the array to the host and management systems. Each control unit has either two Fibre Channel ports or two iSCSI ports as shown in the middle and lower photos respectively. See [Disk drive configurations](#) in Chapter 4 for detailed information about the number and type of disk drives that can be installed in an AMS 2100.

[Figure 1-3](#) shows the front (above) and rear (below) views of the AMS 2100 base unit. The front bezel has been removed in the front view. Expanded views with descriptions of the components are shown in [Chapter 4, Hardware components](#).

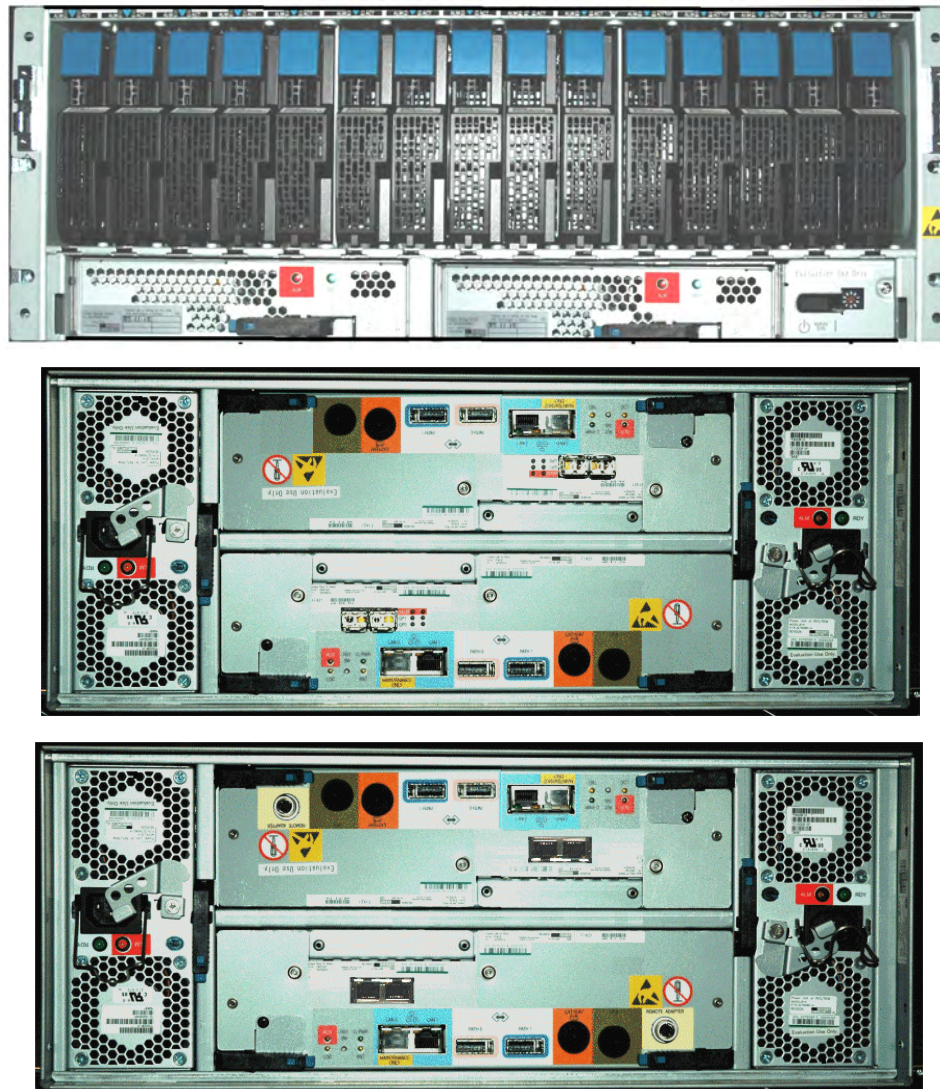

Figure 1-3: AMS 2100 Base Unit Front and Rear Views

AMS 2300 base unit

The Hitachi AMS 2300 Adaptable Modular Storage disk array (model RKM) (hereafter referred to as AMS 2300) includes a base unit and from 0 to 15 expansion units.

- The AMS 2300 base unit contains from 4 to 15 SAS and/or SATA disk drives, two redundant controllers, two redundant power supplies, and two cache battery backup units.
- The AMS 2300 is externally identical to the AMS 2100 except that it has four Fibre Channel ports on each of the two controllers instead of two, or two iSCSI ports, as shown in the figure below. Internally, it has a faster CPU, more RAM, and can have more expansion units and spare drives. See Appendix A and the *Hitachi AMS 2000 Family Storage System Reference Guide* for full specifications. See [Disk drive configurations](#) in Chapter 4 for detailed information about the number and type of disk drives that can be installed in an AMS 2300.

[Figure 1-4](#) shows the front (above) and rear (below) views of the AMS 2300 base unit. The front bezel has been removed in this photo. Expanded views with descriptions of the components are shown in [Chapter 4, Hardware components](#).

Figure 1-4: AMS 2300 Base Unit Front and Rear Views

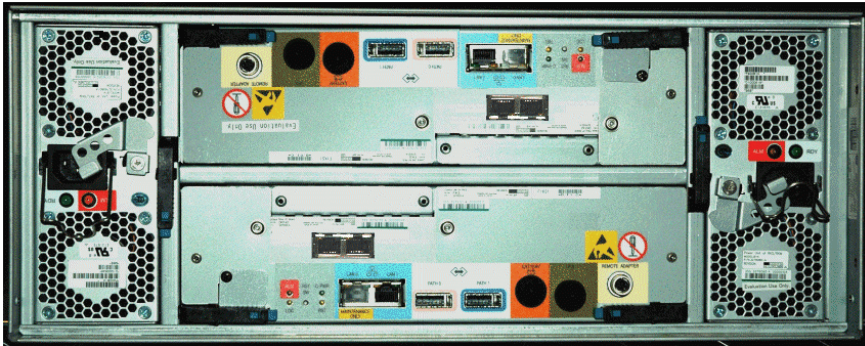
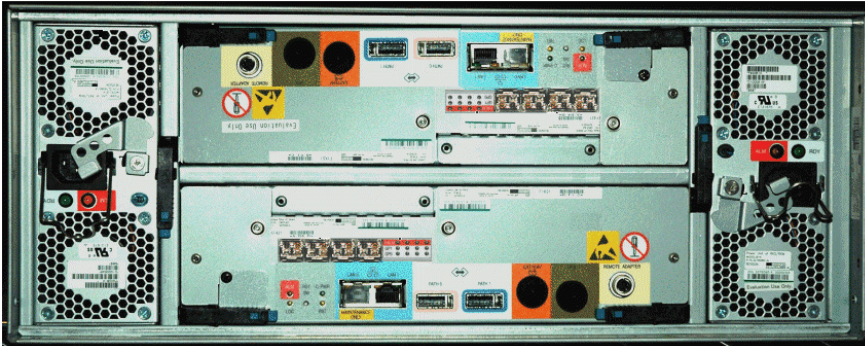
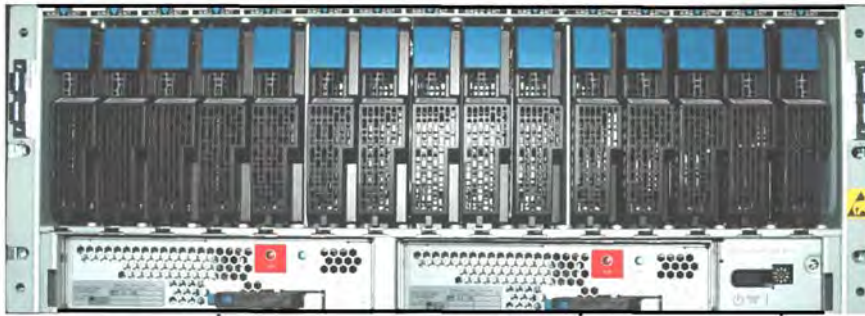

Expansion unit

The Hitachi AMS 2100/2300 expansion unit (Model RKAK) contains from 4 to 15 SAS or SATA disk drives, two redundant power supplies, and two ENC control units. The control units manage the drives and are also used to connect the expansion unit to the base unit and to other expansion units. See [Disk drive configurations](#) in Chapter 4 for detailed information about the number and type of disk drives that can be installed in an expansion unit.

[Figure 1-5](#) shows the front (above) and rear (below) views of the AMS 2100/2300 expansion unit. The front bezel has been removed in this photo. Expanded views are shown in [Chapter 4, Hardware components](#).



Figure 1-5: AMS 2100 /AMS 2300 Expansion Unit Front and Rear Views

High capacity expansion unit

The Hitachi High-density Expansion Unit (Model RKAKX) contains from 4 to 48 SATA disk drives, four redundant power supplies, and four ENC control units (cards). The control units manage the drives and are also used to connect the expansion unit to the base unit and to other expansion units. See [Scalability on page 1-15](#) and [Disk drive configurations](#) in Chapter 4 for detailed information about the number and type of disk drives that can be installed in an expansion unit.

[Figure 1-6](#) shows the front (above) and rear (below) views of the high-density expansion unit. The front bezel has been removed in this photo. Expanded views are shown in [Chapter 4, Hardware components](#).

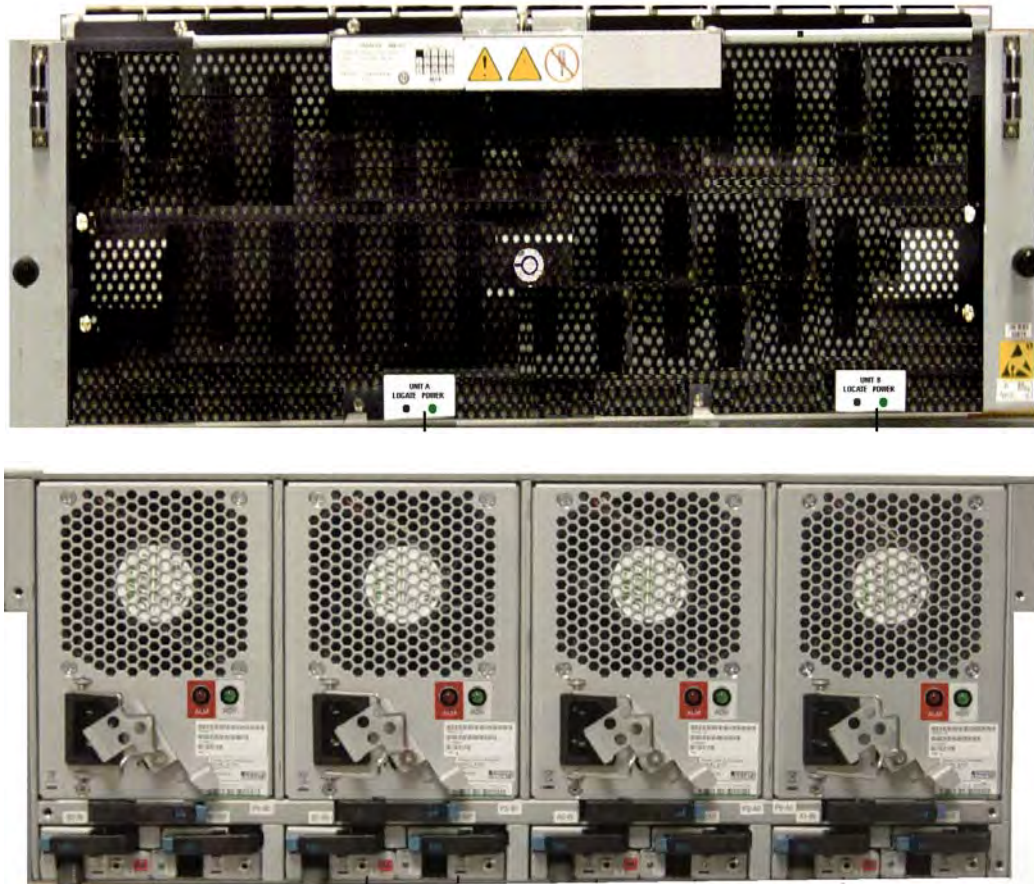

Figure 1-6: High Capacity Expansion Unit Front and Rear Views

Features and benefits

This section describes the main features and benefits of the AMS 2100/2300 disk arrays.

Supported host operating systems

The AMS 2100/2300 supports the following operating systems on host computers. Details for each operating system are described in Hitachi AMS 2000 Family iSCSI Host Installation Guide and Hitachi AMS 2000 Family Fibre Channel Host Installation Guide.

- Microsoft Windows 2008
- Microsoft Windows XP (Service Pack 2)
- Microsoft Windows 2003 and 2003 Server (Service Pack 1)
- Microsoft Windows 2000 (Service Pack 3/4)
- Sun™ Solaris™ v8, v9, and v10.
- HPUX
- Red Hat Linux
- SUSE Linux
- AIX
- Asianux
- Novell NetWare version 6.5 SP6, SP7 (for Fibre Channel only)
- Apple Macintosh OS10 (Fibre Channel only)

High data availability

The AMS 2300 is designed for high performance and protection of user data. See [Reliability, availability, and serviceability on page 1-21](#) for further information on the reliability and availability features of the AMS 2100/2300.

Connectivity

The AMS 2100/2300 supports most open systems through standard Fibre Channel interfaces or standard iSCSI interfaces. The base unit can be configured with control units that have either Fibre Channel interface boards or iSCSI interface boards installed. Both control units must be configured with the same type of interface board.

Fibre channel interface

The AMS 2100 supports two Fibre Channel ports per controller, and the AMS 2300 supports 4 Fibre Channel ports per controller.

The AMS2300 with an 8 Gbps Fibre Channel connection can transfer data between the host computer and the disk array at a maximum speed of 800 MB/s for one port.

In the AMS2100 with a 4 Gbps Fibre Channel connection, the array provides high-speed data transfer between the host computer and the array. The maximum speed is 400 MB/s for one port. Higher throughput can be obtained, even when accessing multiple devices connected on the same Fibre Channel loop.

The array supports open system operations and shortwave multimode optical cables. With these shortwave Fibre Channel cards, the AMS2100/AMS2300 can be located up to 300 meters from the open-system host.

Fibre Channel provides the following capabilities:

Table 1-2: Fibre Channel Features

Feature	Mode	Description
Supported Topologies	Fibre Channel	<ul style="list-style-type: none"> Fibre Channel-AL Point-to-Point F-port
High-speed Data Transfer	Fibre Channel	<p>With the 4 Gbps Fibre Channel connection, the AMS 2100 array can transfer data between the host computer and the array at a maximum speed of 400 MB/sec on each port. An 8 Gbps Fibre Channel connection is possible with the AMS 2300 array. The system provides sufficient throughput, even when accessing multiple devices connected on the same Fibre Channel loop.</p> <p>The AMS 2100 Fibre Channel interface is capable of operating at data transfer speeds of up to 400 MB/sec. The AMS 2100/2300 supports shortwave multimode optical cables. With these shortwave Fibre Channel cards, The AMS 2100/2300 can be located up to 500 meters from the open-system host.</p>
Cable	Fibre Channel	See Table 1-3 below.
Number of Connectable Devices	Fibre Channel	The array supports systems that can connect up to 128 Fibre Channel devices by using the Fibre Channel interface and connecting Fibre Channel-SW.
Security Function	Fibre Channel and Ethernet	When the system is configured to connect multiple hosts, a function is provided that rejects a boot by any host except a specified host. This function can prevent the access from an unauthorized host.

Fibre channel cable

The AMS 2100/2300 supports shortwave multimode optical cables. With these shortwave Fibre Channel cards, the array can be located up to 500 meters from the open-system host. The array can use 50/125m, 62.5/125m multimode fibre cable as defined in [Table 1-3](#), which lists the data transfer rates at specific distances.

Table 1-3: Supported Fiber-Optic Cables and Distances

Cable Length	Distance	
	LPe1150 (@ 4Gb/s)	LPe1250 (@ 8Gb/s)
Max 50/125μ multimode fibre cable (2000MHz*km bandwidth) OM3 (limiting optical receiver, 800-M5E-SN-I)	1246.71 feet (380 m)	492.12 feet (150 m)

Table 1-3: Supported Fiber-Optic Cables and Distances

Cable Length	Distance	
	LPe1150 (@ 4Gb/s)	LPe1250 (@ 8Gb/s)
50/125µm (500MHz*km bandwidth) OM2 (limiting optical receiver, 800-M5-SN-S)	492.12 feet (150 m)	164/04 feet (50 m)
62.5/125µm (200MHz*km bandwidth) OM1 (limiting optical receiver, 800-M6-SN-S)	229/65 feet (70 m)	68.89 feet (21 m)



NOTE: For more information on the Fibre Channel interface, refer to Chapter 4 in the *Hitachi AMS 2000 Family Storage System Reference Guide*, MK-97DF8009.

iSCSI interface

The AMS 2100/2300 provides two iSCSI ports per controller (4 total per base unit). To convert a base unit from Fibre Channel to iSCSI, replace both controllers and install the firmware on them. The same firmware supports both Fibre Channel and iSCSI units.

High-speed data transfer

With the 10 Gbps connection, the array provides high-speed data transfer to and from a host computer. The maximum transfer speed is 1000 MB/s per port. Higher throughput can be obtained, even when accessing multiple devices connected to the same network.

The AMS2100/AMS2300 supports iSCSI (1000 Base-T). With the HBA for iSCSI, generic NIC and software initiator, and network switch, the AMS 2100/2300 can be located up to 100 meters from the host.

Table 1-4: iSCSI Features

Feature	Mode	Description
High-speed Data Transfer	iSCSI	The AMS 2100/2300 supports iSCSI (1000Base-T). With a 1 Gbps Ethernet connection, the iSCSI interface is capable of operating at data transfer speed of up to 100 MB /sec per port. With the HBA for iSCSI, Generic NIC + Software initiator, and Network Switch, the AMS 2100/2300 can be located up to 100 meters. Enough throughput can be obtained even when having multiple access to the multiple devices connected to the same network.
Cable	iSCSI	Category 6 Ethernet cable Maximum cable length: 325 ft. / 100 m
Number of Connectable Devices	iSCSI	The subsystem supports systems that can connect up to 255 hosts for a physical port by using the switch. (When the TrueCopy remote replication function or TrueCopy Extended Distance function is installed and enabled, the maximum number of connectable hosts becomes 239.)
Security	iSCSI	When the system is configured to connect multiple hosts, a function is provided that rejects a boot by any host except a specified host. This function can prevent the access from an unauthorized host.

Table 1-4: iSCSI Features (Continued)

Feature	Mode	Description
CHAP Authentication	iSCSI	User authentication is performed for each target.
iSNS client Function	iSCSI	The iSNS client function enabled to use iSCSI device discovery, state change notification on the network easily
Ping	iSCSI	You can ping the network to verify whether the device at a specified address and the AMS 2100/2300 can communicate with IP network. This function specifies the address that Navigator 2 sends the ping from the iSCSI interface, and then displays a response. However, pinging an unreachable address might cause a delay and time-out of the host I/O processing on the controller. A warning message will be displayed before starting a Ping test. Hitachi Data Systems strongly recommended that you ping the network only when no host I/O exists on the controller.
MTU Parameter	iSCSI	The AMS2100/AMS2300 with an optional 10 Gbps iSCSI interface board can select the MTU (Maximum Transfer Unit) parameter from 1500, 4500, or 9000 bytes. Selecting a large size for the MTU parameter can improve the transfer efficiency. To select a large size, set the MTU parameter for the Ethernet port on the host side or for the Ethernet Switch that exists in the network at the value equal to or higher than the value set in the AMS2100/AMS2300.

Scalability

Using the components available, users can construct a variety of systems that meet a wide range of needs, as described here.

- A single AMS 2100 base unit that contains from 4 to 15 disk drives, or a larger system using a single AMS 2100 base unit with 4-15 drives and attached expansion units and/or high-density expansion units. The AMS 2100 supports a maximum of 159 drives.
- A single AMS 2300 base unit that contains from 4 to 15 disk drives, or a larger system using a single AMS 2300 base unit with 4-15 drives and attached expansion units and/or high-density expansion units. The AMS 2300 supports a maximum of 240 drives.
- **When RKS/RKES connect RKA KS/RKAKX, disk drive can be mounted up to 159 units.**
- **When RKM connect RKA KS, disk drive can be mounted up to 231 units.**
- **When RKEM connect RKA K/RKA KS/RKAKX, disk drive can be mounted up to 255 units.**

However, when mounting subsystems mixing RKA Ks and RKA Ks or RKA Ks/RKA Ks and RKA Ks, a maximum of Disk Drives can not be mounted. For more details, refer to [Table 1-5 on page 1-16](#).



NOTE: The configuration other than the number of Additional Chassis displayed in each table can be created, but the unusable slots increase in the chassis. The slot indicates the installation place of Disk Drives in the chassis. The number of slots in the Additional Chassis is as follows: RKA K: 15 slots, RKA KS: 24 slots and RKA KX: 24 slots each for RKA KX-A and RKA KX-B

Table 1-5: Mounted Number of Additional Chassis (RKAK and RKAKS) and the Maximum Mountable Number of Disk Drives

Basic Chassis (one unit)	RKAK mounted additional chassis	RKAKS mounted additional chassis	Max mountable number of disk drives
RKS/RKES	0	6	159
	1	5	150
	3	4	156
	4	3	147
	5	2	138
	6	1	129
	7	0	120
RKM	0	9	231
	2	8	237
	3	7	228
	5	6	234
	7	5	240
	8	4	231
	10	3	237
	11	2	228
	13	1	234
15	0	240	
RKEM	0	10	255
	1	9	246
	3	8	252
	4	7	243
	6	6	249
	8	5	255
	9	4	246
	11	3	252
	12	2	243
	14	1	249
	15	0	240

For further details, see the following two tables.

Table 1-6: Minimum and Maximum System Configurations

Base Unit			Expansion Unit				
	Disk Drives		Type	Units		Disk Drives	
	Min	Max		Min	Max	Min	Max
AMS 2100	4	15	Expansion Unit (RKAK)	0	7	2 per unit	15
			Modular 2U Expansion Unit (RKAKS)	0	8	2 per unit	24
			High-density Expansion Unit (RKAKX)	0	3	2 in each section of the unit ¹	48
AMS 2300	4	15	Expansion Unit (RKAK)	0	15	2 per unit	15
			Modular 2U Expansion Unit (RKAKS)	0	8	2 per unit	24
			High-density Expansion Unit (RKAKX)	0	4	2 in each section of the unit ¹	48

1. Minimum supported HDS configuration is two disk drives installed in slots 0 and 1 in Unit A, and two drives installed in slots 0 and 1 in Unit B.

Using an AMS 2000 rack, you can construct a system that meets your needs by combining base units and expansion units as shown in the following tables.

Table 1-7: AMS 2100 High-density Expansion Unit Intermix

Unit	Expansion Units 15 Disk Drives	High-density Expansion Units 48 disk Drives	Maximum Number of Disk Drives	
			SATA/SAS7.2K	SAS/SAS(SSED)
AMS 2100	0	2	111	91
	1	1	78 ¹	68
	2	1	93	83
	3	1	108 ²	98
	3	2	156	136
	4	0	75	75
	5	0	90	90
	5	1	138	128
	6	0	105	105
	7	0	120 ³	120
	0	3	159	129

1. Maximum number of disk drives using only high-density expansion units.

2. Maximum number of disk drives using intermix of expansion units and high-density expansion units.
3. Maximum number of disk drives using only expansion units.

Table 1-8: AMS 2300 High-density Expansion Unit Intermix

Unit	Standard Expansion Units 15 Disk Drives	Dense Expansion Units 48 Disk Drives	Maximum Number of Disk Drives		Status
			SATA/ SAS7.2K	SAS/ SAS(SED)	
AMS 2300 (1 RK2)	0	4	207	167	Maximum with dense expansion units
	1	4	222	182	
	2	3	189	159	
	3	3	204	174	
	4	3	219	189	
HW Rev 0100	5	3	234	204	Maximum with intermix of expansion units
	6	2	201	181	
	7	2	216	196	
	8	1	183	173	
	9	1	198	188	
	10	1	213	203	
	11	1	228	218	
	12	0	195	196	
	13	0	210	210	
	14	0	225	225	
	15	0	240	240	Maximum with standard tray

- To use AMS 2100/2300 systems efficiently, Hitachi Data Systems recommends that users mount a spare drive in each of the unused drive slots. Up to 15 spare disks can be set up in any location with an AMS 2100 and up to 30 spare disk drives with an AMS 2300.
- From the host computer, the array can be used not only as a single-large scale disk drive but also as 2048 logical disks (logical units) maximum in an AMS 2100 and 4096 logical units in an AMS 2300.

Fibre channel interface

The AMS2100/AMS2300 supports open system operations. The AMS2100/AMS2300 supports up to 4 fibre-channel ports. The AMS2300 Fibre Channel interface is capable of operating at data transfer speeds of up to 800 MB/sec. The AMS2100 Fibre Channel interface is capable of operating at data transfer speeds of up to 400 MB/sec. The AMS2100/AMS2300 supports shortwave multimode optical cables. With these shortwave fibre channel cards, the AMS2100/AMS2300 can be located up to 860 meters from the open-system host.

iSCSI interface

The AMS2100/AMS2300 provides 4 iSCSI ports (for the case of the dual Controller configuration) by installing an optional iSCSI interface board. The iSCSI interface is capable of operating at data transfer speed of up to 1000 M bytes/s (when the 10G bps iSCSI interface board is installed).

The AMS2100/AMS2300 supports 1G bps or 10G bps iSCSI (1000Base-T). With the HBA for iSCSI, Generic NIC + Software initiator, and Network Switch, the AMS2100/AMS2300 subsystem can be located up to 100 meters. **With the 10G bps iSCSI, with 50/125 um multimode (OM3/OM2) Cable, the AMS2100/AMS2300 subsystem can be located up to 300 (OM3) meters, or 82 (OM2) meters.**

High capacity cache

The AMS 2100/2300 supports a maximum of 4 GB high capacity cache per control unit. This cache configuration supports immediate reporting to a host when data is written from the host to the cache. This is explained in detail in the next section.

Cache management

The cache management function works as described in the following process.

1. Data is stored in the cache when reading and writing. It is dynamically managed depending on the workload read and write I/O characteristics. The high percent cache hit rate is expected due to the transaction processing that the data is updated after referencing the data. The system throughput is increased by the reduced data writing time.
2. As soon as data is written onto the cache, it is reported to the host. The write operation onto the disk will be asynchronously performed later. Because the host does not have to wait for the data to be written to a disk drive, it can perform the next process immediately, significantly improving system performance.



NOTE: Even if there is an electric power failure during the write process, the data is saved because the cache is nonvolatile. For data assurance time, refer to [Table 1-9 on page 1-20](#).

3. One specified logical unit from the host per controller can be resident in the cache. The high throughput can be realized for the specified logical unit since 100% cache percent hit rate is expected when reading from the host and writing.
4. Optimum segment size can be specified by dividing cache memory into multiple partitions in accordance with applications, and then cache memory can be effectively used and tuned according to user system by occupying cache memory by certain logical units.

Cache specifications

The Cache specifications are shown in [Table 1-9](#).

Table 1-9: Cache Specifications

Item	Description
AMS 2100	
Capacity (MB per controller)	2,048, 4,096
Control method	Read LRU / Write After ¹
Battery backup	Provided
Backup duration (h) ²	48 hrs when cache is 8,192 MB (4,096 MB per controller) 72 hrs when cache is 4,096 MB (2,048 MB per controller)
AMS 2300	
Capacity (MB per controller)	4,096, 8,192 MB
Control method	Read LRU / Write After ¹
Battery backup	Provided
Backup duration (h) ²	24 hrs when cache is 16,384 MB (8,192 MB per controller) 36 hrs when cache is 8192 MB (4,096 MB per controller)

1. LRU = Least Recently Used. An algorithm where new items are placed at the top of the cache and items at the bottom of the cache are discarded when the cache grows past its size limit. Whenever an item is accessed, it is pulled back to the top of the cache.

2. Backup time in hours with two full charged cache backup batteries.

Performance reporting and monitoring

The Navigator 2 storage management software provides the capability to either monitor the disk array in real-time or collect historical data regarding the performance of the storage system.

Reliability, availability, and serviceability

Dynamic load balance

When connecting two or more hosts, the automatic load adjustment function operates between the Control Units supported by the “Dynamic Load Balance Controller.” Therefore, it is not necessary to take into consideration which controller the hosts are connected to.

High reliability

The AMS 2100/2300 array controller increases data reliability by adding original 8 byte data assurance codes to data from a host computer. It automatically generates the assurance codes across the data bus in the control unit assigned to the disk drive, and then writes them to the disk drive along with the data. In addition, it automatically checks the codes when reading the data. This significantly enhances data reliability in the data distribution/concentration controller that is assigned to the disk array

Spare disks

An AMS 2100 can include up to 15 spare disks per array. An AMS 2300 can include up to 30 spare disks per array. The AMS 2100/2300 arrays monitor the disk drives for potential failure. The data copy operation can be automatically performed in the background, before a failure actually occurs. In addition, the redundancy of the dynamic sparing feature enables the spare disk to be replaced while the system is running (excluding RAID 0 configuration), thereby increasing the reliability of the array even more. The data recovery to the new disk drive can be performed in running on the system.

To maintain system reliability, HDS recommends that you include at least one spare disk drive for each 15 disk drives in an array with SATA disk drives.

Replacing an active failed disk drive

The AMS 2100/2300 array includes an online data recovery function that enables users to replace, or “hot swap,” a failed active disk drive with a spare drive while the array is running. Data on the failed disk is recovered and copied to the new disk drive while the array is running and performing other functions at the same time.

Redundant power supplies

The AMS 2100/2300 array includes two identical power supplies running in parallel. If either of these power supplies fails, the other can provide sufficient power to the system by itself. The array is designed to allow a failed power supply to be replaced (hot swapped) while the array is running. The array monitors the power supplies for correct operation and provides an alert to the Navigator 2 storage management software if the voltages provided by the power supplies do not meet the system specifications.

RAID implementations

The AMS 2100/2300 supports RAID 0, RAID 1+0, RAID 1, RAID 5, RAID 6, or an intermix, as described below.

Table 1-10: RAID Implementations

RAID Level	Description
0	<p>RAID 0 group stripes data across all disk drives in the group to attain higher throughput. There is no sparing disk drive function with this configuration.</p> <p>Notes:</p> <ul style="list-style-type: none"> When a failure occurs in a disk drive, data cannot be restored internally within the disk array because RAID 0 has no data redundancy. Therefore, although the host receives an error message, the data is left in its current state. Unlike with an independent disk drive, error block management (assignment of alternative block for the independent disk drive with the Reassign Blocks command) is not done. Therefore, when a RAID 0 disk drive becomes inaccessible due to a failure, all the logical units in the RAID 0 configuration including the failed disk drive become inaccessible. Restoration of user data with backup data is essential after replacing the failed disk drive. Do not allow RAID 0 to coexist with another RAID group. Do not form a group with two or more RAID 0 systems, for example (4D + 1P) × 2 + 2D. Each time a failure occurs in a RAID 0 disk drive, data that cannot be written into the disk drive (pinned data) is accumulated in the cache. When the amount of accumulated data exceeds a certain value, a write I/O instructed to the other RAID group will not be accepted and the system will crash. In this case, restoration of user data and resynchronization of a file system using the backup data are required for the entire array. The recovery time for this procedure can be quite long. Do not adopt the RAID 0 configuration to its fullest extent. Consider the above notes when building the configuration.
1+0 ¹	<p>RAID 1+0 groups provide data redundancy like RAID 1 by copying all the contents of two disk drives to another pair. Different from RAID 1, data striping is performed for a maximum of 16 sets of two disk drives.</p>
1	<p>RAID 1 array groups consist of at least two disk drives in a mirrored configuration. Data is mirrored across the groups of two adjacent drives. The stripe consists of two data chunks.</p>
5	<p>RAID 5 uses from 2 to 15 data disks, and has a parity disk performing the data striping.</p>
6	<p>RAID 6 uses from 2 to 28 data disks, and has two parity disks performing the data striping. Configuration with two parity disks provides the redundancy that can sustain two points failures.</p>

1. RAID 0+1 is described in place of RAID 1+0 in some places in this document. However, it has the same meaning as RAID 1+0.

The AMS 2100/2300 RAID specifications are shown in [Table 1-11](#).

Table 1-11: AMS 2100/2300 RAID Specifications

Item	RAID level	Base Unit	Expansion Units and High Capacity Expansion Unit (range for setup)
RAID Configuration	SAS/SAS(SSED)/SAS7.2K/Flash drives can be mounted with RAID levels 0, 1, 5, 6, & 1+0. SATA drives can be mounted only with RAID levels 1, 5, 6, & 1+0		
	RAID 0	2D to 15D SATA drives do not support RAID 0.	2D to 16D
	RAID 1	1D+1D	
	RAID 5	2D+1P to 14D+1P	2D+1P to 15D+1P
	RAID 6	2D+2P to 13D+2P	2D+2P to 28D+2P
	RAID 1+0	2D+2D to 7D+7D	2D+2D to 8D+8D

Open systems features and functions

The AMS 2100/2300 offers many features and functions specifically for the open-systems environment. The AMS 2100/2300 also supports important open-system functions such as fibre-channel arbitrated-loop (Fibre Channel-AL) and fabric topologies, command tag queuing, multi-initiator I/O, and most industry-standard software and middleware products which provide host fail-over, I/O path fail-over, and logical volume management functions.

Open systems middleware

Open-system middleware products provide host failover capability, I/O path failover support, and logical volume management in the open systems environment. Middleware is not usually supplied as part of the array's basic operating system.

Logical unit mapping

Each logical unit can be assigned to multiple Fibre Channel ports to provide I/O path failover with the middleware support.

Data management features and functions

The AMS 2100/2300 includes several high-performance features that implement easy and fast data management. These features are described in [Table 1-12](#).

Table 1-12: Data Management Features and Functions

Feature	Description
Cache Residency Manager	The Cache Residency Manager feature makes data of specific logical units resident in a cache and makes all accesses to the LUs from the host cache hit without making any disk accesses occur. When the function is applied to a logic unit frequently accessed, it is expected that the throughput is increased because all data Read/Write can be performed as cache hits.
LUN Manager	The LUN Manager feature consists of two main functions for Fibre Channel and two for iSCSI: <ul style="list-style-type: none"> The Fibre Channel security function controls the access from specific hosts or specific commands. The host group function (for Fibre Channel interface) enables also the array to make a suitable response to each host connected even within the same port by grouping connected hosts within a port and setting the logical unit mapping and the Host Connection mode for each host group. Up to 128 host groups can be set The iSCSI security function controls the access from specified hosts or specific commands. iSCSI target interface. The iSCSI security function controls access from specified hosts or specific commands.
LUN Expansion	The LUN Expansion feature is used to expand the size of logical unit (volume) to which a host computer accesses by combining multiple logical units (volumes) internally.
Data Retention Utility	The Data Retention Utility feature prevents the logical unit (volume) from being accessed illegally by the host.
Audit Logging Function	The Audit Logging function generates a syslog to audit the event when the user performs the setting operation for the disk array system, and outputs the syslog to the external server.
Account Authentication Function	The Account Authentication function authenticates login to the array unit based on the account information registered by the user and controls the access to the array resource. This prevents the illegal operation by the unauthorized person.
Audit Logging Function	The Audit Logging function generates a syslog to audit the event when the user performs the setting operation for the disk array system, and outputs the syslog to the external server.
Dynamic Provisioning	Dynamic provisioning is a function that improves the capacity efficiency of disk drives by assigning physical capacity On Demand at the time of the Write command receipt without assigning the physical capacity to logical units.

Table 1-12: Data Management Features and Functions

Feature	Description
Data At Rest Encryption	The Data At Rest Encryption allows a self encrypting drive with the function encrypting/decoding the stored data to be used as an installed disk drive for encrypting the data to be stored in the array.

Copy solution features and functions

The AMS 2100/2300 supports several copy solutions as described in the following table.

Table 1-13: Copy Solution Features and Function

Feature	Description
TrueCopy Remote Replication	The TrueCopy remote replication function continuously synchronizes the data on two arrays connected by a Fibre Channel interface, ensuring that both arrays always contain the same data. In addition, this function significantly improves copying speed by transferring only differential data.
TrueCopy Extended Distance	The TrueCopy Extended Distance (TCED) function continuously synchronizes the data on two arrays connected by a Fibre Channel interface, ensuring that both arrays always contain the same data. TCED also increases copying speed by transferring only differential data.
ShadowImage In-System Replication	The ShadowImage in-system replication function controls logical unit copying done within one and the same array. It can create a copy (secondary volume) of a logical unit within one and the same array keeping the redundancy that the source logical unit (primary volume) has.
Copy-on-write SnapShot	The Copy-on-write SnapShot feature enables you to maintain a logical copy of logical units (volumes) at a point in time within the same disk array system.
Modular Volume Migration	The Modular Volume Migration function migrates the logical unit which receives the host operation to another RAID group within a disk array system.

Performance management features and functions

The AMS 2100/2300 supports several performance functions as described in [Table 1-14](#).

Table 1-14: Performance Management Features and Functions

Feature	Description
Performance Monitor Function	This function acquires information on performance of RAID groups and logical units, etc. in the array, and utilization rates of resources such as hard disk drives and processors. The information acquired is displayed with line graphs.
Cache Partition Manager Function	This function enhances system performance by cache area division, segment size specification, and assignment for separate logical units.

Failure monitoring features and functions

The AMS 2100/2300 supports failure monitoring solutions, as described in [Table 1-15](#).

Table 1-15: Failure Monitoring Features and Functions

Feature	Description
SNMP Agent Support Function	<p>The SNMP Agent Support Function reports occurrences of failure to the workstation for monitoring the network via the SNMP (Simple Network Management Protocol) of the open platform.</p> <p>The SNMP Agent Support Function does not support IPv6. When performing the failure monitoring, execute it by IPv4 or use the E-mail alert function.</p>

E-mail alert function

The E-mail alert function e-mails failure information to the previously registered mail address from the subsystem when a failure has occurred in the subsystem.

The E-mail alert function can e-mail immediately after failure detection without a time lag by monitoring. It is able to detect failure occurrence instantly even at a distant place.

If data in cache memory is lost due to the subsystem going down from a power outage and battery failure, the email settings return to the settings that were in effect when you started the array for the first time. If this condition occurs, check the email settings after recovering the array. Refer to Help in the Hitachi Storage Navigator Modular 2.



NOTE: If you are sending E-mail alerts to a service provider, please contact the service provider or dealer before changing the settings of E-mail alert and/or management LAN/network.

Power saving features and functions

The AMS 2100/2300 supports power saving solutions, as described in [Table 1-16](#).

Table 1-16: Failure Monitoring Features and Functions

Feature	Description
Power Saving Support Function	Power Saving reduces the electric power consumption of the AMS 2100/2300 by spinning down the disk drives which included in a user-specified RAID group. The drives are still turned on, but the drive motors are stopped.

Email alert notification

When a failure occurs in an AMS 2100/2300 and error monitoring is enabled, the Navigator 2 email alert feature sends email messages containing failure information to up to three previously registered email addresses when a failure has occurred in the array. The email alert feature detects failures at the instant they happen, and immediately sends failure notices to the designated recipients.

If the subsystem goes down due to a power outage or battery failure, the email settings return to their default settings. Therefore, check and reconfigure the e-mail setting after recovering the array from such failures. For more information about the e-mail Alert function, refer to Help in the Hitachi Storage Navigator Modular 2.

The email alert feature is explained in detail in the Navigator 2 online help system. [Figure 1-7](#) shows an example of system construction of the email alert feature.

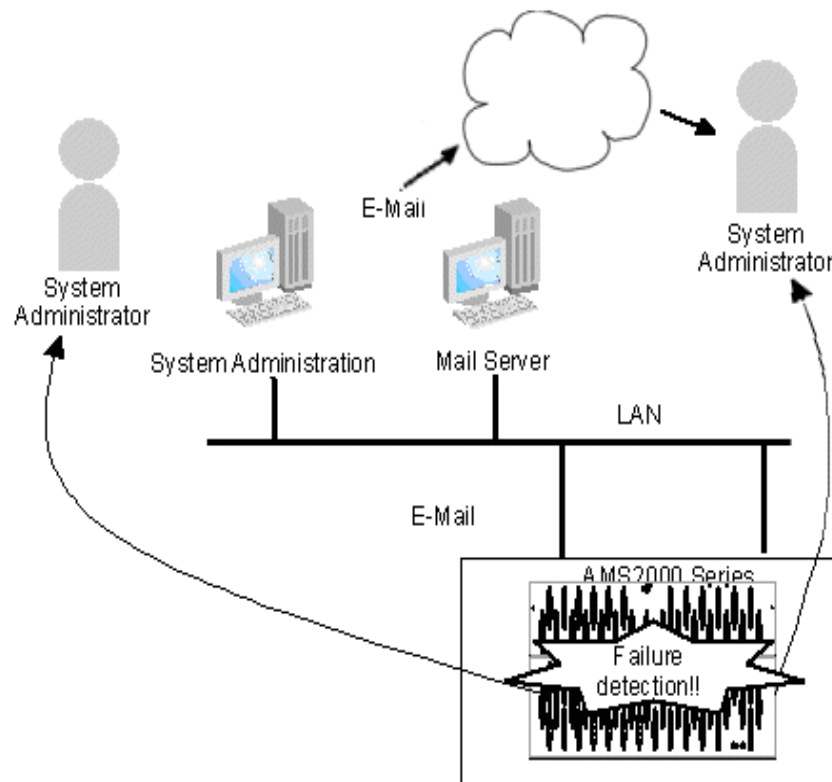

Figure 1-7: Example of System Construction of Email Alert Feature

Cooperative function with VMware

AMS2100/AMS2300 adapts to vStorage API that VMware provides.

To allow the function, you need to enable the following Hosts Connection Parameters. The parameters become automatically enabled if you select VMware as your platform.

- Unique Extended COPY Mode

- Unique Write Same Mode

For details, see the *VMware Version Host Installation Guide for Fibre Channel Connection* or the *VMware Version Host Installation Guide for iSCSI Connection*.



NOTE: When AMS2100/AMS2300 has a battery failure, the advantages of this function cannot be obtained. If the ownership of source and destination LUs differs when Cooperative Function with VMware operates, the ownership of the target LU is changed to that of the source LU. This ownership change operates regardless of the setting status of load balancing. To avoid ownership change, set `DataMover.HardwareAcceleratedMove` to 0 in ESX.

Long term array storage

The cache backup batteries in a Hitachi AMS 2000 Family Storage System array cannot hold a charge indefinitely. If you do not use an AMS 2100/2300 for six months or more, move the batteries to a system that is being used, or turn the array on for at least 24 hours once every six months.



CAUTION! If the AMS 2100/2300 is not energized for more than 6 months, the battery will likely discharge completely. When the battery completely discharges, it may be damaged and you may not be able to recharge it. To prevent this from happening, charge the battery for a minimum of 24 hours at least once every six months.

Functional and operational characteristics

This chapter describes the basic features of the Hitachi AMS 2000 Family Storage System. It contains the following key topics:

- ❑ [Overview of the AMS 2100/2300 storage system](#)
- ❑ [Array specifications](#)
- ❑ [Fibre channel interface](#)
- ❑ [iSCSI interface](#)
- ❑ [Required parts](#)
- ❑ [Optional parts](#)
- ❑ [Accessory parts](#)

Overview of the AMS 2100/2300 storage system

Architecture and components

The system architecture of the AMS 2100 and AMS 2300 are similar, as is their physical construction. Both arrays contain many of the same components. The block diagrams in this section show the differences and similarities of the two units.

AMS 2100 configuration architecture

This section contains the configuration block diagrams of the AMS 2100 base unit. Each controller contains two Fibre Channel ports or two iSCSI ports, depending on which interface board is installed in the controller. The AMS 2100 includes the following features:

- An AMS 2100 base unit and expansion unit can mount up to 15 disk drives. A modular 2U SAS expansion unit can mount up to 24 disk drives. A high-density expansion unit can mount up to 48 disk drives. See [Disk drive configurations](#) in Chapter 4 for information about the number and type of disc drives that can be installed in each unit.
- An AMS 2100 base unit includes two control units that can control up to 159 disk drives each in a RAID configuration.
- The disk drives in the base unit, expansion units, and high-density expansion units can be assigned to data disk(s), parity disk(s) or (mirror disk(s)) depending on the RAID level.
- Up to 15 spare disks can be mounted in any locations within an AMS 2100 configuration.

[Figure 2-1](#) shows the configuration block diagram of an AMS 2100 array. [Table 2-1](#) provides a description of each numbered part.

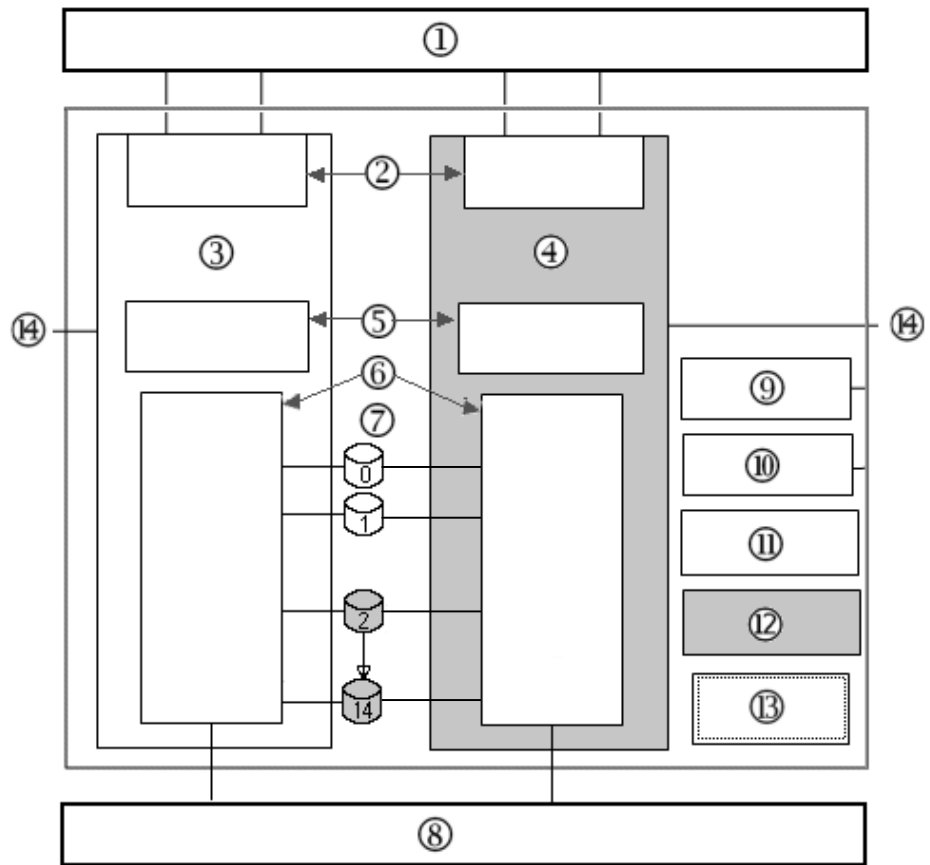

Figure 2-1: AMS 2100 Configuration Block Diagram

Table 2-1: AMS 2100 Configuration Block Diagram

Item	Description	Item	Description	Item	Description
①	Host System	⑥	SAS/SATA Control	⑪	Backup Battery #0 Backs up the cache in control unit 0
②	Fibre Channel Interface OR iSCSI interface (both must be the same type.)	⑦	Disk Drives ¹	⑫	Backup Battery #1 Backs up the cache in control unit 1
③	Control Unit #0	⑧	Expansion Unit or High-density Expansion Unit	⑬	Switch Panel
④	Control Unit #1	⑨	Power Supply #0	⑭	LAN (to management console)
⑤	Cache memory	⑩	Power Supply #1		

1. Supported disk drives: DF-F800-AKH146, DF-F800-AKH300, DF-F800-AKH450, DF-F800-AKF400, DF-F800-AWE2K, DF-F800-AVE500, DF-F800-AKH600, DF-F800-ANH600, DF-F800-AVE1K, DF-F800-AVE2K, DF-F800-AVE3K, DF-F800-AKS200

AMS 2300 configuration architecture

This section contains the configuration block diagrams of the AMS 2300 base unit. Each controller in the base unit contains four Fibre Channel ports or two iSCSI ports. The AMS 2300 includes the following features:

- An AMS 2300 base unit and expansion unit can mount up to 15 disk drives each. A high-density expansion unit can mount up to 48 disk drives each. See [Disk drive configurations](#) in Chapter 4 for information about the number and type of disc drives that can be installed in each unit.
- An AMS 2300 base unit includes two control units that can control up to 240 disk drives each in a RAID configuration.
- The disk drives in the base unit, expansion units, and high-density expansion units can be assigned to data disk(s), parity disk(s) or (mirror disk(s)) depending on the RAID level.
- Up to 30 spare disks can be mounted in any locations within an AMS 2300 configuration.

[Figure 2-2](#) shows the configuration block diagram of an AMS 2300 array. [Table 2-2](#) provides a description of each numbered part.

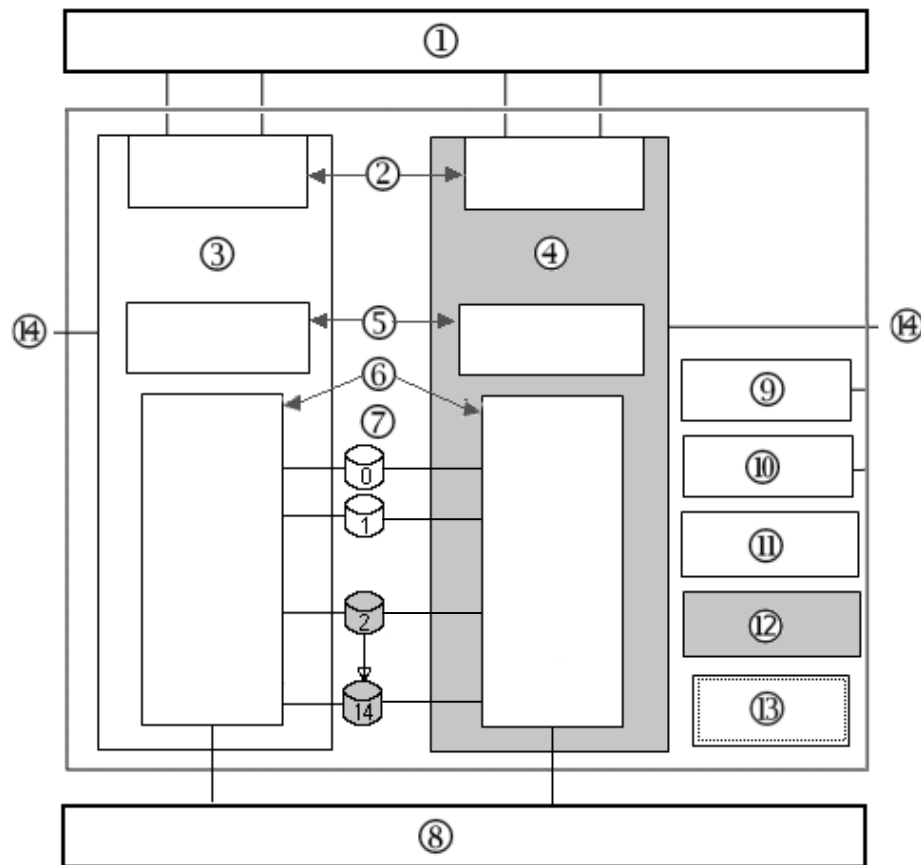

Figure 2-2: AMS 2300 Configuration Block Diagram

Table 2-2: AMS 2300 Configuration Block Diagram

Item	Description	Item	Description	Item	Description
①	Host System	⑥	SAS/SATA Control	⑪	Backup Battery #0
②	Fibre Channel or iSCSI interface (both must be the same type.)	⑦	Disk Drives ¹	⑫	Backup Battery #1
③	Control Unit #0	⑧	Expansion Unit or High-density Expansion Unit	⑬	Switch Panel
④	Control Unit #1	⑨	Power Supply #0	⑭	LAN (to management console)
⑤	Cache memory	⑩	Power Supply #1		

1. Supported disk drives: DF-F800-AKH146, DF-F800-AKH300, DF-F800-AKH450, DF-F800-ANH600, DF-F800-AKF400, DF-F800-AWE2K, DF-F800-AVE500, DF-F800-AKH600, DF-F800-AVE1K, DF-F800-AVE2K, DF-F800-AVE3K, DF-F800-AKS200

Expansion unit architecture

Figure 2-3 shows the configuration block diagram of an AMS 2000 Family expansion unit. Table 2-3 provides a description of each numbered part.

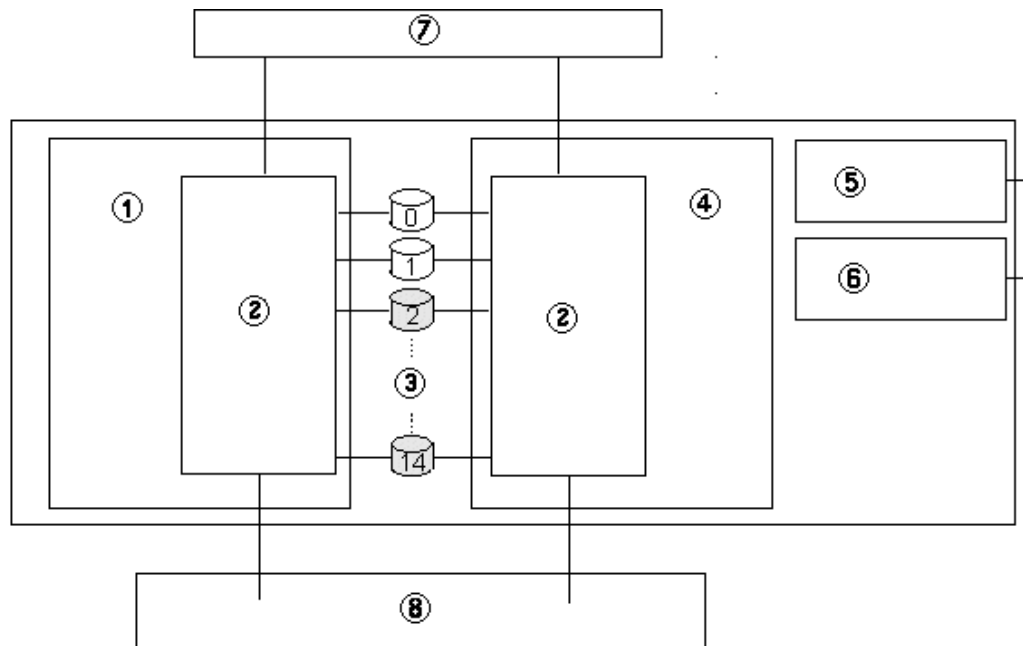

Figure 2-3: Expansion Unit Block Diagram

Table 2-3: Expansion Unit Block Diagram

Item	Description	Item	Description
①	ENC Unit 0	⑤	Power Supply 0
②	SAS / SATA Control	⑥	Power Supply 1
③	Disk Drives ¹	⑦	From Base or Expansion Unit
④	ENC Unit 1	⑧	To Expansion Unit

1. Supported disk drives: DF-F800-AKH146, DF-F800-AKH300, DF-F800-AKH450, DF-F800-AKH600, DF-F800-ANH600, DF-F800-AKF400, DF-F800-AWE2K, DF-F800-AVE500, DF-F800-AVE1K, DF-F800-AVE2K, DF-F800-AVE3K, DF-F800-AKS200

Modular 2U SAS expansion unit RKAKS architecture

The following illustration shows the configuration block diagram of an AMS 2000 Family Modular 2U SAS RKAKS expansion unit.

*1 Disk Drive: DF-F800-AMF300, DF-800-AMF600

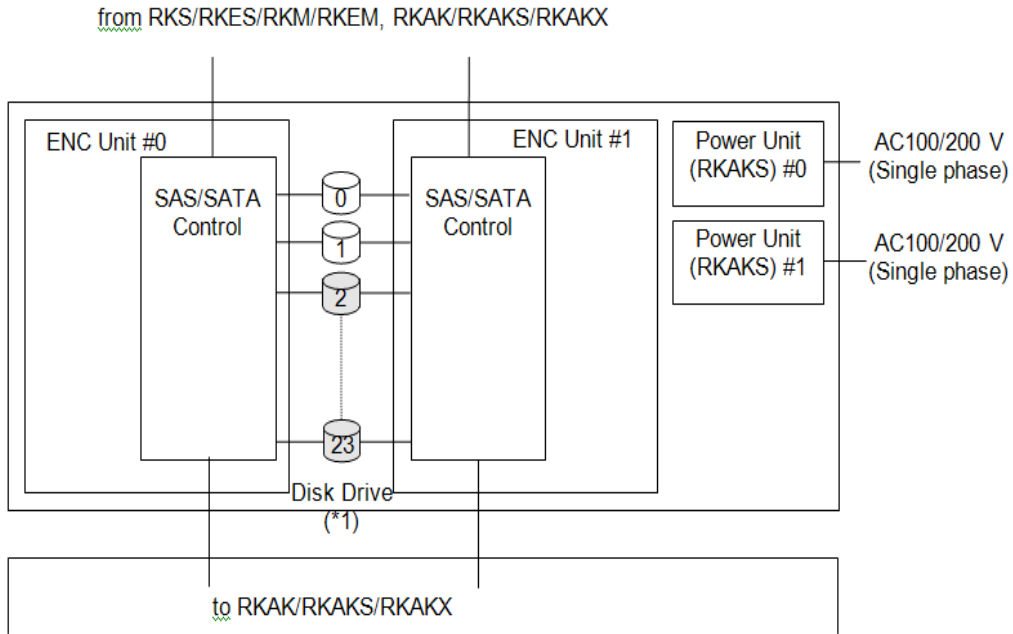

Table 2-4: System Configuration of the RKAKS

High-density expansion unit architecture

The following illustration shows the configuration block diagram of an AMS 2000 Family high-density expansion unit. The table following the illustration provides a description of each numbered part.

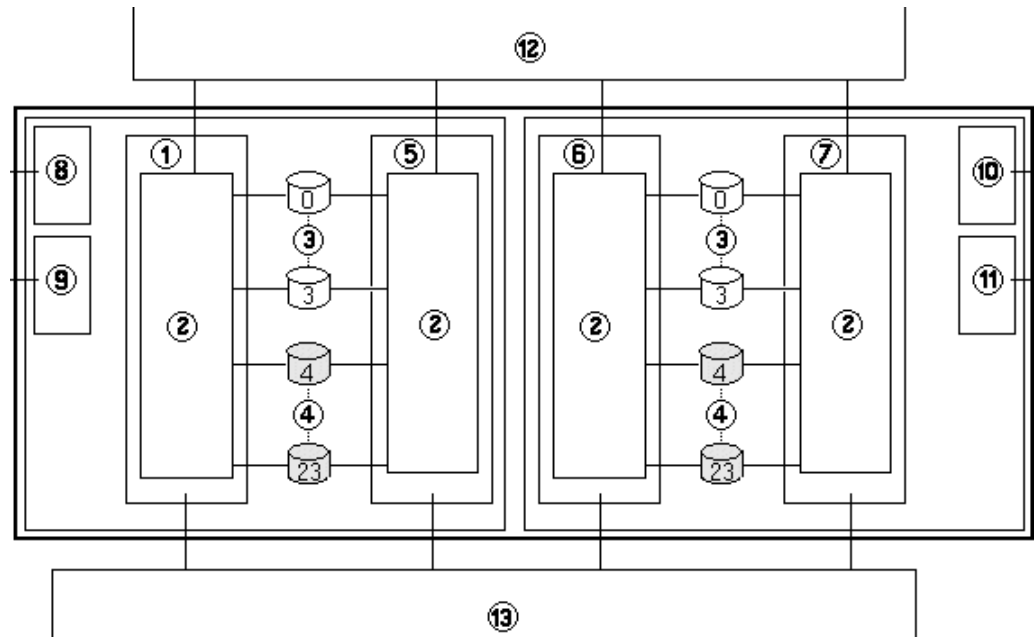

Figure 2-4: High-capacity Expansion Unit Block Diagram

Table 2-5: High-capacity Expansion Unit Block Diagram

Item	Description	Item	Description
①	ENC Unit A0	⑧	Power Supply A0
②	SAS / SATA Control	⑨	Power Supply A1
③	Disk Drives ¹ Drives 0 -3 are required. Drives 4 - 23 are optional	⑩	Power Supply B0
④	Disk Drives ¹ Drives 4 - 23 are optional	⑪	Power Supply B1
⑤	ENC Unit A1	⑫	From Base Unit, Expansion Unit, or High-density Expansion Unit
⑥	ENC Unit B0	⑬	To Expansion Unit or High-density Expansion Unit
⑦	ENC Unit B1		

1. Supported disk drives: DF-F800-ANH600X, DF-F800-AKH450X, DF-F800-AKH600X (SAS drives), DF-F800-AVE1KX, DF-F800-AVE2KX (SATA), DF-F800-AVE3KX(SATA drives) , DF-F800-AWE2KX (SAS7.2K drive),

Array specifications

Each AMS 2100/2300 base unit and expansion unit contains the physical disk drives, including the disk array groups and the dynamic spare disk drives.

Each rack has dual AC power distribution units (PDU). Each PDU is connected to a different power source, so that if one source fails, the other will still supply power to the arrays.

The AMS 2100 array can be configured with one AMS 2100 base unit and from 0 to 7 expansion units or a maximum of one high-density expansion unit for a maximum total of 120 disk drives. Using 3 TB disk drives, this configuration provides a maximum of 330.7 TB of storage space in RAID 5 (14D+1P) configuration. See [Table 1-7](#) for specifications regarding mixing expansion units and high-density expansion units.

The AMS 2300 array can be configured with one AMS 2300 base unit and from 0 to 15 expansion units or up to four high-density expansion units for a maximum total of 240 disk drives. Using 3 TB disk drives, this configuration provides a maximum of 661.5 TB of storage space in RAID 5 (14D+1P) configuration. See [Table 1-7](#) for specifications regarding mixing expansion units and high-density expansion units.

The basic specifications of the AMS 2100/2300 are shown in [Table 2-6](#).

Table 2-6: Basic AMS 2100/2300 Specifications

Configuration		AMS 2100 Base Unit	AMS 2300 Base Unit	Expansion Unit	High Capacity Expansion Unit
Disk Drives	Disk drive size inches (mm)	Width: 4 / 101.6 Depth: 5.79 /147.0 (Max.) Height: 1.03 / 26.1 (Max.) RKAKS: 81.6 / 205.718.7(2.5 Type)			
	Data capacity (GB) ¹	142.61/195.82/287.62/392.73/439.44/491.25/575.30/983.69/1956.94/1968.52 ² /2953.31 (3.5 Type) RKAKS: 287.62/575.30(2.5 Type)			
	Rotational speed (RPM)	15,000 RPM: 142.61/287.62/439.44/575.30 GB 10,000 RPM: 392.73 GB 7,200 RPM: 491.25/983.69/1956.94/1968.52/2953.31 GB ² Flash Drive: 195.82 GB RKAKS: 287.62/575.30:10,000(2.5Type)			
	Maximum mountable quantity (unit)	15	15	15 RKAKS: 24	38 (SAS/SAS(SSED) drive) 48 (SATA drive), 48 (SAS7.2K drive)
Host Interface	Interface type	AMS2100: 4 Gbps Fibre Channel Optical AMS2300: 4 Gbps / 8 Gbps Fibre Channel Optical 1 Gbps iSCSI (1000Base-T) 10 Gbps (Optical) iSCSI			
	Data transfer speed (i.e. maximum speed for transfer to host)	AMS2100: 400 MB/sec (Fibre Channel) AMS2300: 800 MB/sec (Fibre Channel) 1000 MB/s (iSCSI)			
	Number of host connectors (dual controllers)	Fibre Channel 2 per control unit, 4 total	Fibre Channel 4 per control unit, 8 total		
		iSCSI 2 per control unit, 4 total	iSCSI 2 per control unit, 4 total		
Transferred block size (bytes)	512	512			

1. The drive capacity values are calculated as 1 G byte =1,000,000,000 bytes. This definition is different from that calculated as 1 k byte =1,024 bytes, which displays on the PC you are using. The RAID group capacity values displayed in the Hitachi Storage Navigator Modular 2 are calculated as 1 k byte =1,024 bytes. See the Preface of this manual for more information on storage capacity values.

2. RKAKX supports 439.44 G bytes, 575.30 G bytes, 983.69 G bytes, 1956.94 G bytes, 1968.52 or 2953.31 G bytes.

Fibre channel interface

The AMS 2100/2300 supports open system operations. The AMS 2100 supports up to 4 fibre-channel ports and the AMS 2300 supports to 8 Fibre Channel ports. The AMS 2100/2300 Fibre Channel interface shortwave multimode optical cables and operates at data transfer speeds up to 400 MB/sec. With these shortwave Fibre Channel cards, the AMS 2100/2300 can be located up to 500 meters from an open-system host.



NOTE: For more information about the Fibre Channel interface, see Chapter 3, Interfaces, in the *Hitachi AMS2100/AMS2300 Series Disk Array System Reference Guide*.



NOTE: Set the "Transfer Rate" of Fibre Channel to the value corresponding to the transfer rate of devices connected directly with an array according to the following table. When the AMS 2100/2300 is connected directly and externally with the Universal Storage Platform/ Network Storage Controller, set the port transfer rate of both the Universal Storage Platform/ Network Storage Controller and the AMS 2100/AMS 2300 to the fixed transfer rate (the same value for the Universal Storage Platform and the AMS 2100/2300 selecting any one of 1 Gbps, 2 Gbps, or 4 Gbps).

Table 2-7: Fibre Channel Transfer Rates

Transfer Rate of Devices Connected with an Array (Gigabits per second)	Transfer Rate of an Array Subsystem (Gigabits per second)
1	1
2	2
4	4
8	8
Auto (Maximum speed 8)	8
Auto (Maximum speed 4)	4
Auto (Maximum speed 2)	2



NOTE: When connecting an AMS 2100/2300 directly and externally with a Universal Storage Platform/Network Storage controller, set the topologies of both devices to "Loop".

iSCSI interface

The AMS 2100/2300 provides 4 iSCSI ports in each base unit (2 per controller). The iSCSI interface is capable of operating at data transfer speed of up to 1000 MB/s when the 10G bps iSCSI interface board is installed.

The AMS 2100/2300 supports iSCSI (1000Base-T). With the HBA for iSCSI, Generic NIC + Software initiator, and Network Switch, the array can be located up to 100 meters from the host computer. With the 10G bps iSCSI, with 50/125 um multimode (OM3/OM2) Cable, the AMS2100/AMS2300 subsystem can be located up to 300 (OM3) meters, or 82 (OM2) meters.

For the 1G bps iSCSI, connect the switch based on the 1000BASE-T (full-duplex). Use the LAN cable with the following types and shapes.

- Cable type: category 5e or category 6
- Connector: RJ-45

For the physical port of the switch to be connected directly with the host and the iSCSI port of the AMS 2100/2300, do not set the Spanning Tree protocol function to ON. It may cause communications interference.

For the 10G bps iSCSI, use the following optical cable:

- 50/125 um multimode (OM2) Cable
- 50/125 um multimode (OM3) Cable

Setting iSCSI information

The following iSCSI information is set for iSCSI ports (it is not set for Fibre Channel ports).

- iSCSI Port IP address
- iSNS Server
- Adding target
- Target option

The host should log into the specified target of AMS2100/AMS2300 in iSCSI, unlike Fibre Channel. (Refer to the HBA or iSCSI software initiator manuals for information about logging in to the target.) In some initiators, the subsequent re-connection will be done automatically.

Required parts

Table 2-8 describes the required components for AMS 2100/2300 arrays.

Table 2-8: AMS 2100/2300 Required Parts

Name	Model	Components ¹
Base Unit (RK2)	DF-800-RK2	Frame (1), Front Bezel (1), Panel (1), Backup battery unit (2), AC cable J2H (2), Power unit (2)
One or more of the listed disk drives ²	DF-F800-AKH146	3.5-type Disk drive (142.61 GB) installed in a canister. (15,000 RPM)
	DF-F800-AKH300	3.5-type Disk drive (287.62 GB) installed in a canister. (15,000 RPM)
	DF-F800-AMF300	3.5-type Disk drive (287.62 GB) installed in a canister. (15,000 RPM)
	DF-F800-AKF400	3.5-type Disk drive (392.73 GB) installed in a canister. (10,000 RPM)
	DF-F800-AKH450	3.5-type Disk drive (439.44 GB) installed in a canister. (15,000 RPM)
	DF-F800-AKH450X	3.5-type Disk drive (439.44 GB) installed in a canister. (15,000 RPM) (for RKAKX)
	DF-F800-AVE500	3.5-type Disk drive (491.25 GB) installed in a canister. (7,200 RPM)
	DF-F800-AMF600	3.5-type Disk drive (491.25 GB) installed in a canister. (7,200 RPM)
	DF-F800-AKH600	3.5-type Disk drive (575.30 GB) installed in a canister. (15,000 RPM)
	DF-F800-ANH600 ³	3.5-type Disk drive (575.30 GB) installed in a canister. (15,000 RPM)
	DF-F800-ANH600X ³	3.5-type Disk drive (575.30 GB) installed in a canister. (15,000 RPM) (for RKAKX)
	DF-F800-AVE1K	3.5-type Disk drive (983.69 GB) installed in a canister. (7,200 RPM)
	DF-F800-AVE1KX	3.5-type Disk drive (983.69 GB) installed in a canister. (7,200 RPM) (for RKAKX)
	DF-F800-AWE2K	3.5-type Disk drive (1956.94 G bytes) installed in a canister. (7,200 RPM)
	DF-F800-AWE2KX	3.5-type Disk drive (1956.94 G bytes) installed in a canister. (7,200 RPM) (for RKAKX)
	DF-F800-AVE2K	3.5-type Disk drive (1968.52 GB) installed in a canister. (7,200 RPM)
	DF-F800-AVE2KX	3.5-type Disk drive (1968.52 GB) installed in a canister. (7,200 RPM) (for RKAKX)
DF-F800-AVE3K	3.5-type Disk drive (2953.31 G bytes) installed in a canister. (Disk rotational speed: 7,200 min ⁻¹)	
DF-F800-AVE3KX	3.5-type Disk drive (2953.31 G bytes) installed in a canister. (Disk rotational speed: 7,200 min ⁻¹) (for RKAKX)	
DF-F800-AKS200	Flash Drive (195.82 GB) installed in a canister.	

Table 2-8: AMS 2100/2300 Required Parts

Name	Model	Components ¹
Storage Features ⁴		Features bundled on the Navigator 2 installation CD. See Storage features on page 7-11 for the complete list of included and optional storage features. <ul style="list-style-type: none"> • Audit Logging and Account Authentication • LUN Manager • Cache Residency Manager and Cache Partition Manager • Modular Volume Migration • SNMP Agent Support • Data Retention • Performance Monitor
Resource Manager ⁵	P-002D-J400	Utility which integrates the following products: <ul style="list-style-type: none"> • Media provided: CD-ROM • Hitachi Storage Navigator Modular 2 • SNMP Agent Support function and Password Protection • Cache Residency Manager
Hitachi Storage Navigator Modular 2	P-002D-J401	Navigator 2 Storage Management Software

1. Numbers in parentheses following component names show quantities of the components.
2. These values of storage capacity are calculated as 1 GB = 1,000,000,000 bytes. This definition is different from that calculated as 1 k byte = 1,024 bytes. The RAID group capacity values displayed in the Hitachi Storage Navigator Modular 2 are calculated as 1 k byte = 1,024 bytes. See the Preface of this manual for more information on storage capacity values.
3. For more details about SAS(SSED) Drive functions and features, refer to *Data At Rest User's Guide*.
4. Basic Storage Features are installed in the AMS 2100 as standard.
5. Resource Manager is attached to the basic chassis as standard.

Optional parts

Table 2-9 describes the optional components for AMS 2100/2300 arrays.

Table 2-9: AMS 2100/2300 Optional Parts

Classification	Part Number	Name	Description ¹
Spare Disk	-	Disk drive	Refer to disk drive information.
Additional Disk Drive	-	Disk drive	Refer to disk drive information.
Expansion Unit (RKAK)	DF-F800-RKAK ²	Expansion Unit	Frame (1), AC cable J2H (2), Power unit (RKAK) (2), ENC unit (2), ENC cable (1m) (2)
Modular 2U SAS Expansion Unit (RKAKS)	DF-F800-RKAKS ²	Modular 2U SAS Expansion Unit	Frame (1), AC cable J2H (2), Power unit (RKAK) (2), ENC unit (2), ENC cable (1m) (2)
High-density Expansion Unit (RKAKX)	DF-F800-RKAKX ²	High-density Expansion Unit	Frame (1), AC cable J2H (4), Power unit (RKAKX) (4), ENC unit (X), ENC cable (3m) (4)
Controller for AMS 2100 base unit (2 required per base unit)	HDF-F800-SFC2 3282005-C	Control unit	2 Fibre Channel ports 2,048 MB Cache
	HDF-F800-SIS2 3282005-D		2 iSCSI ports 2,048 MB Cache
	HDF-F800-SFC4 3282005-G		2 Fibre Channel ports 4,096 MB Cache
	HDF-F800-SIS4 3282005-H		2 iSCSI ports 4,096 MB Cache
Controller for AMS 2300 base unit (2 required per base unit)	HDF-F800-MFC4 3282005-A	Control unit	4 Fibre Channel ports 4,096 MB Cache
	HDF-F800-MIS4 3282005-E		2 iSCSI ports 4,096 MB Cache
	HDF-F800-MFC8 3282005-B		4 Fibre Channel ports 8,192 MB Cache
	HDF-F800-MIS8 3282005-F		2 iSCSI ports 8,192 MB Cache
HDS AMS 2000 Rack	7846630	AMS 2000 Rack	1050 mm Deep w/30 amp Nema PDU (4)
	7846631	AMS 2000 Rack	1050 mm Deep w/30 amp IEC PDU (4)
	7846634	AMS 2000 Rack	Type E Rack 1050 mm deep w/30 amp IEC PDU (4)
Remote Adapter	DF-F800-VR4A	Remote adapter (Main unit)	Adapter for PS interlock control (Power cables for 100V and 200V each are standard equipment)
	DF-F800-VR4H	Remote adapter (Hub)	Hub for remote adapter (Power cables for 100V and 200V each are standard equipment)

Table 2-9: AMS 2100/2300 Optional Parts (Continued)

Classification	Part Number	Name	Description ¹
Power Cable	DF-F800-J1H	Power cable	2.5 m, 2-pole power cable with grounding terminal (AC 125 V, 13 A or 15 A)
	DF-F800-J2H	Power cable	2.5 m, 2-pole power cable with grounding terminal (AC 250 V, 13 A or 15 A)
	DF-F800-J2H5	Power cable	5.0 m, 2-pole power cable with grounding terminal (AC 200 V, 13 A or 15 A)
	DF-F800-J2H10	Power cable	10.0 m, 2-pole power cable with grounding terminal (AC 200 V, 13 A or 15 A)
Cable Assembly	DF-F800-K1BS	ENC cable assembly	ENC cable 1m (2)
Cable Assembly	DF-F800-K3BS	ENC cable assembly	ENC cable 3 m (2)
Cable Assembly	DF-F800-K5BS	ENC cable assembly	ENC cable 5 m (2)
Fibre Channel interface Cable Everywhere except Japan	FICSMLCLC025M.P	Fibre Channel interface Cable	SC/LC Fibre FICON Single Mode 9UM Cable 25M
	FICSMLCLC050M.P		SC/LC Fibre FICON Single Mode 9UM Cable 50M
	FICSMLCLC100M.P		SC/LC Fibre FICON Single Mode 9UM Cable 100M
	FICSMSCLC025M.P		LC/LC Fibre Single Mode 9UM Cable 25M
	FICSMSCLC050M.P		LC/LC Fibre Single Mode 9UM Cable 50M
	FICSMSCLC100M.P		LC/LC Fibre Single Mode 9UM Cable 100M
Fibre Channel interface Cable EMEA only	JZ-050LL005.P	Fibre Channel interface Cable	LC/LC Duplex Fibre Optic 50UM Cable 5M
	594-100M.P		SC/LC Duplex Fibre Optic 50UM Cable 100M
	594-10M.P		SC/LC Duplex Fibre Optic 50UM Cable 10M
	594-1M.P		SC/LC Fiber Optic 50UM Cable 1M
	594-25M.P		SC/LC Duplex Fibre Optic 50UM Cable 25M
	594-50M.P		SC/LC Duplex Fibre Optic 50UM Cable 50M
	594-5M.P		SC/LC Duplex Fibre Optic 50UM Cable 5M
	FICSMLCLC005M.P		SC/LC Fibre FICON Single Mode 9UM Cable 5M
	FICSMLCLC010M.P		SC/LC Fibre FICON Single Mode 9UM Cable 10M
	FICSMSCLC005M.P		LC/LC Fibre FICON Single Mode 9UM Cable 5M

Table 2-9: AMS 2100/2300 Optional Parts (Continued)

Classification	Part Number	Name	Description ¹
Fibre Channel interface Cable EMEA only	FICSMSCLC010M.P	Fibre Channel interface Cable	LC/LC Fibre FICON Single Mode 9UM Cable 10M
	JZ-050LL005PC.P		LC/LC Duplex Fibre Optic 50UM Cable 5M
	JZ-050LL010PC.P		LC/LC Duplex Fibre Optic 50UM Cable 10M
	JZ-050LL025PC.P		LC/LC Duplex Fibre Optic 50UM Cable 25M
	JZ-050LL050.P		LC/LC Duplex Fibre Optic 50UM Cable 50M
	JZ-050LL100.P		LC/LC Duplex Fibre Optic 50UM Cable 100M
Fibre Channel interface Cable Everywhere except EMEA and Japan.	JZ-050LL010.P	Fibre Channel interface Cable	LC/LC Duplex Fibre Optic 50UM Cable 10M
	JZ-050LL025.P		LC/LC Duplex Fibre Optic 50UM Cable 25M
	JZ-050LL050PC.P		LC/LC Duplex Fibre Optic 50UM Cable 50M
	JZ-050LL100PC.P		LC/LC Duplex Fibre Optic 50UM Cable 100M
	JZ-050SL005PC.P		SC/LC Duplex Fibre Optic 50UM Cable 5M
	JZ-050SL010PC.P		SC/LC Duplex Fibre Optic 50UM Cable 10M
	JZ-050SL025PC.P		SC/LC Duplex Fibre Optic 50UM Cable 25M
	JZ-050SL050PC.P		SC/LC Duplex Fibre Optic 50UM Cable 50M
	JZ-050SL100PC.P		SC/LC Duplex Fibre Optic 50UM Cable 100M
Control cable for External Backup Battery Unit	DF-F800-K1N	Control cable for External Backup Battery Unit	Interlocking control cable for the External Backup Battery Unit

Table 2-9: AMS 2100/2300 Optional Parts (Continued)

Classification	Part Number	Name	Description ¹
Storage Features		Power Saving	This feature reduces power consumption by turning off the drive motors in a selected group of drives in the array.
		Data Retention Utility	Protects the disk array data and LUNs from input/output (I/O) operations performed by open-systems hosts.
		In-System Replication Suite	ShadowImage in-system replication Copy-on-write Snapshot
		ShadowImage	This feature is used to make a copy of a logical unit (volume) within an array unit.
		Copy-on-write Snapshot	This function is used to make a point-in-time copy of a logical unit (volume) between array units.
		TrueCopy Remote Replication	This feature equalizes data of disk array subsystems by always synchronizing their data.
		TrueCopy Extended Distance	This feature equalizes data of disk array subsystems by always synchronizing their data asynchronously.
	P-002D-Jxxx	P-002D-Jxxx	The Dynamic Provisioning is a function to improve the capacity efficiency of disk drives by assigning physical capacity On Demand at the time of the Write command receipt without assigning the physical capacity to logical units.
Rack Assembly	AMS 2000 Rack	AMS 2000 Rack	See Hitachi AMS 2000 Site Preparation Guide.

1. Numbers in parentheses show quantities of the components.

2. For AMS2300, when the system is configured with a mix of RKAK and RKAKX, DF-F800-K3BS or DF-800-5KBS ENC, the cables need to be separately purchased.

Accessory parts

Table 2-10 lists the accessory parts for the AMS 2100/2300.

Table 2-10: AMS 2100/2300 Accessory Parts ¹

Classification	Model	Name	Specification
Power Cables	DF-F800-J1H	Power Cable	2.5 m, 2-pole power cable with grounding terminal (AC 125 V, 13 A or 15 A)
	DF-F800-J2H		2.5 m, 2-pole power cable with grounding terminal (AC 250 V, 13 A or 15 A)
	DF-F800-J2H5		5.0 m, 2-pole power cable with grounding terminal (AC 200 V, 13 A or 15 A)
	DF-F800-J2H10		10.0 m, 2-pole power cable with grounding terminal (AC 200 V, 13 A or 15 A)
	A-F6516-P620		Power cable for PDB (2)
	A-F6516-P630		Power cable for PDB (2)
Fibre Channel Interface Cables	A-6515-GM10S	SC-LC Fibre I/F Cable	SC-LC Fibre I/F cable for Optical (10 m)
	A-6515-GM20S		SC-LC Fibre I/F cable for Optical (20 m)
	A-6515-GM30S		SC-LC Fibre I/F cable for Optical (30 m)
	A-6515-GM50S		SC-LC Fibre I/F cable for Optical (50 m)
	A-6515-GM1JS		SC-LC Fibre I/F cable for Optical (100 m)
	A-6515-GM5L	LC-LC Fibre I/F Cable	LC-LC Fibre I/F cable for Optical (5 m)
	A-6515-GM10L		LC-LC Fibre I/F cable for Optical (10 m)
	A-6515-GM20L		LC-LC Fibre I/F cable for Optical (20 m)
	A-6515-GM30L		LC-LC Fibre I/F cable for Optical (30 m)
	A-6515-GM50L		LC-LC Fibre I/F cable for Optical (50 m)
	A-6515-GM1L		LC-LC Fibre I/F cable for Optical (100 m)
Cable assembly	DF-F800-K5BS	ENC cable assembly	ENC cable 5 m (1)
Rack Rail	DF-F800-URHT7	Rail kit for Rack	Rail kit for Rack (for HA8000/8500)
	DF-F800-UR7	Rail kit for Rack	Rail kit for HP, EP8000, SUN, AP7000 Rack
	DF-F800-URX8	Rail kit for Rack	Rail kit for Rack (for RKAKX)

Table 2-10: AMS 2100/2300 Accessory Parts (Continued)¹

Classification	Model	Name	Specification
Remote adapter cable	DF-F800-VRC2	Remote adapter cable	For control of Remote adapter, 2 m
	DF-F800-VRC5	Remote adapter cable	For control of Remote adapter, 5 m
	DF-F800-VRC10	Remote adapter cable	For control of Remote adapter, 10 m
	DF-F800-VRC20	Remote adapter cable	For control of Remote adapter, 20 m
	DF-F800-VRC50	Remote adapter cable	For control of Remote adapter, 50 m

1. Numbers in parentheses following component names show quantities of the components.

Getting started

This chapter provides an overview of the tasks to install and configure a Hitachi Adaptable Modular Storage 2100/2300 Storage System. It covers the following key topic:

- [Task roadmap](#)

Task roadmap

Table 3-1 lists and describes the required and optional tasks that users should and can do to install, set up, configure, and manage the AMS 2100/2300 array.

Table 3-1: Procedures for Installing and Configuring the AMS 2100/2300

Step	Task	Description
Required Tasks		
1	Unpack the array	Unpack and inspect the array components. See Unpacking an array on page 5-24 .
2	Mount the array in a rack	Install the rail kits and mount the base and expansion units. Connect power cables. See Mounting the array on page 5-33 .
3	Connect cables	Connect the ENC cables and either Fibre Channel or iSCSI data cables. See Connecting ENC cables (expansion unit) on page 5-36 , Connecting Fibre channel cables on page 5-51 , and Connecting iSCSI cables on page 5-52 .
4	Connect a management PC to the array	Connect the LAN cable. See Connecting cables on page 5-35 .
5	Attach the front bezel	See Turning the array ON on page 5-53 .
6	Turn the array on.	See Chapter 6, Power On/Off procedures .
7	Turning the array off	See Chapter 6, Power On/Off procedures .
8	Configuring the array - required configuration	See Chapter 7, Configuration .
9	Configuring host system and storage	Add arrays to Navigator 2 and configure them. See Chapter 7, Configuration .
Optional Tasks		
1	Configuring the array - optional Configuration	See Chapter 7, Configuration .
2	Upgrade the Hardware	Add Disk Drives. See Chapter 9, Upgrading the hardware .
3	Upgrade the Firmware	Download the firmware and install it. See Chapter 10, Upgrading the firmware .
4	Upgrade the Software	Install a new version of Navigator 2. See Installing Navigator 2 on page 7-12 .

Hardware components

This chapter describes the components, controls, connectors and indicators of the Hitachi Adaptable Modular Storage 2100/2300 Storage System. It covers the AMS 2100 and AMS 2300 base units, the expansion unit, and the high-density expansion unit, and explains the functions of various parts of the units. This chapter covers the following key topics:

- ❑ [The base unit](#)
- ❑ [Standard expansion units](#)
- ❑ [Modular 2U SAS expansion unit](#)
- ❑ [High-density expansion unit](#)

The base unit

This section describes the base unit and its components, controls, and indicators.

Base unit front panel

This section describes each of the components on the front of the base unit. The following illustration shows the front of a base unit with the decorative bezel installed (upper photo) and removed in the lower photo, with the components on the front of the unit exposed. Both the AMS 2100 and the AMS 2300 unit models are the same on the front.

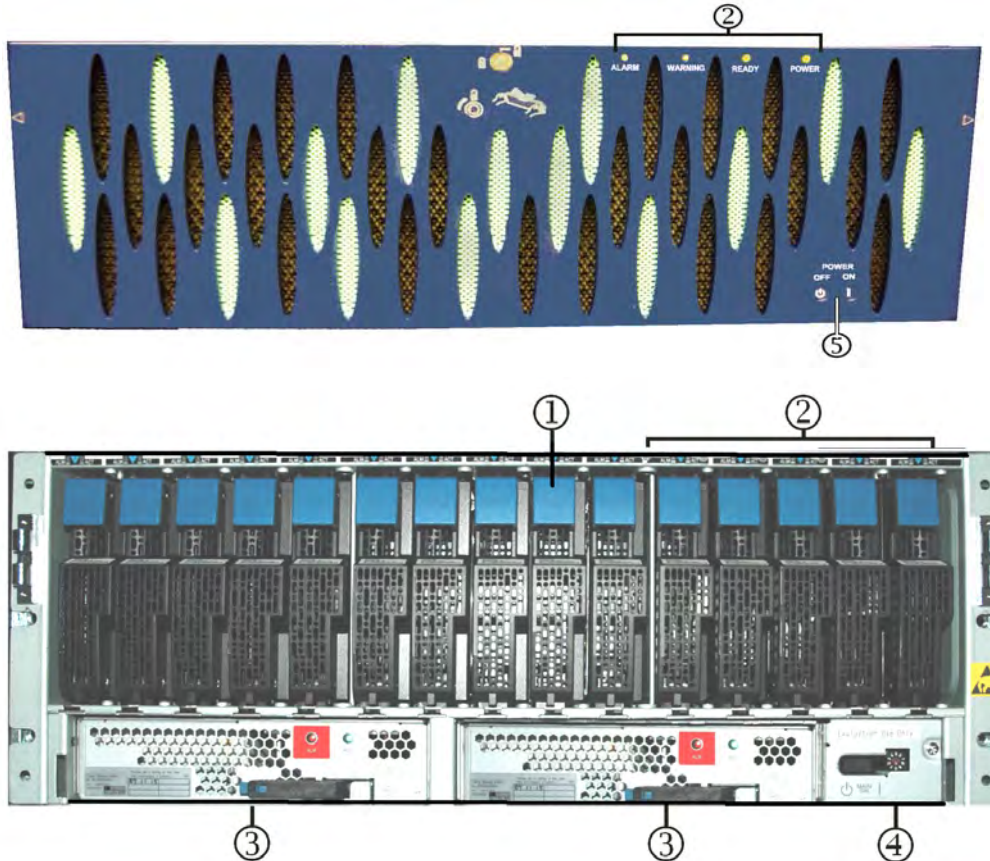

Figure 4-1: AMS 2100 Base Unit Front View

Table 4-1: Base Unit Front View

Item	Description	Item	Description
①	Disk Drives	③	Cache Backup Battery (#0 on left, #1 on right). See Cache backup batteries on page 4-5 for details.
②	Base Unit Status LEDs See Base unit status LEDs on page 4-4 for details.	④	Switch Panel (Power and Mode switches). See AMS 2100 base unit on page 1-6 and Switch panel on page 4-7 for details.

Disk drives

As shown by item #1 in [Figure 4-1](#), an AMS 2100/2300 has 15 drive slots in the front of the array. Each slot can accommodate one SATA drive or one SAS drive.

Disk drive configurations

The following requirements are for both the AMS 2100 and the AMS 2300 base units. See the section on expansion units for configuration information about them.

- The minimum number of drives that must be installed in the base unit is four. The first four drives must be installed in slots 0 - 3 and must be either all SAS drives or all SATA drives.
- The minimum number of disk drives in an expansion unit is two. These must be installed in slots 0-1 and must both be either SAS or SATA drives.
- After the minimum configuration is met in the base unit or the expansion unit, you can add up to two SAS or two SATA drives (which makes a RAID 1 configuration) at a time, or other combinations of drives as required to meet the RAID configurations specified in [RAID implementations on page 1-22](#).

Disk drive status LEDs

The base unit has two LEDs that are built into the unit chassis above each disk drive slot. These LEDs, shown in [Figure 4-2](#), indicate the status of the drive that is installed in the slot below them. The number in the triangle is the slot number of the disk drive.

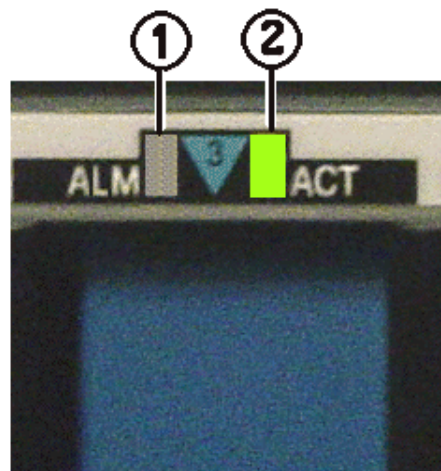

Figure 4-2: Disk Drive Status LEDs

Table 4-2: Disk Drive Status LEDs

Item	Description	Item	Description
①	ALarM LED (red) Lights when the drive has a serious error.	②	ACTive LED (green) Lights or flashes when the drive is operating and is being read from or written to. It indicates that the disk drive is operational.

Base unit status LEDs

Front panel

The upper right edge of the front of the AMS 2100/2300 base unit has four LEDs that indicate the status of the array. Also built into the chassis are two status LEDs for each disk drive. In addition, the Cache Backup battery has two status LEDs. [Figure 4-3](#) and [Table 4-3](#) describe the front panel status LEDs and their functions.

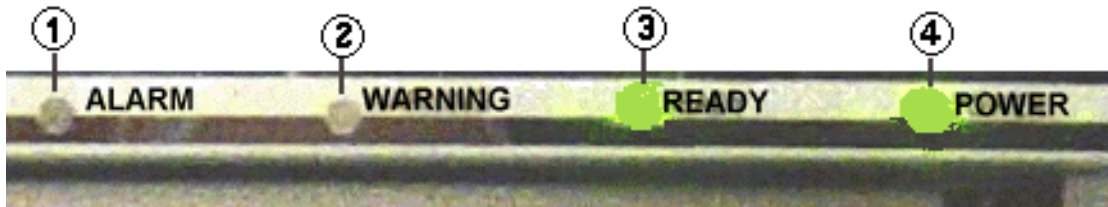

Figure 4-3: Base Unit Status LEDs (front panel)

Table 4-3: Base Unit Status LEDs (front panel)

Item	Name/Color	Status	Description
Unit Overall Status LEDs			
①	Alarm (red)		The Alarm LED shows when an AMS 2100/2300 array has encountered a serious error.
		OFF	Normal operation
		ON	A serious error has occurred in the array. Please contact Hitachi Data Systems Technical Support. See the Getting Help section in the Preface of this manual.
	Slow Blink (1 blink/sec)	A serious failure has occurred. Please contact Hitachi Data Systems Technical Support. See the Getting Help section in the Preface of this manual.	
②	Warning (orange)		The (orange) Warning LED shows when the base unit is operating normally, has encountered a non-serious error, or is upgrading the firmware.
		OFF	Normal operation
		ON or Slow Blink (1 blink/sec)	Non-serious error. The base unit can continue to operate. See the Alerts & Events window in Navigator 2 for information about the error.
	Fast Blink (8 blinks/sec)	The firmware is being updated (do not turn off the array).	
③	Ready (green)	ON	Normal operation. The array is fully operational.
		Slow Blink	Firmware download is complete. The array is fully operational.
		Fast Blink	Not a failure. The firmware is being updated (do not turn off the array).
④	Power (green)	ON	The base unit is turned on and receiving power.
		OFF	The base unit is not turned on.

Table 4-3: Base Unit Status LEDs (front panel) (Continued)

Item	Name/ Color	Status	Description
Disk Drive Status LEDs (see Disk drive status LEDs on page 4-3).			
①	ALarM LED (red)	ON	Lights when the drive has a serious Error.
		OFF	Normal Status
②	ACTive LED (green)	ON or Flashing	Lights or flashes when the drive is operating and is being read from or written to. It indicates that the disk drive is operational.
		OFF	No data is being transferred
Cache Backup Battery (see Cache backup batteries on page 4-5)			
②	Alarm LED (red)	ON	Indicates that the battery has failed.
		OFF	Indicates that the battery status is normal.
③	Ready LED (green) indicates battery condition	ON	Normal status
		Slow Blink	(1 blink per second): The battery is not fully charged.
		Off or Fast Blink	(8 blinks per second): Abnormal status

Rear panel

The rear panel of the AMS 2100/2300 base unit has several LEDs that indicate the status of the power supplies and control units. These LEDs are explained as part of the descriptions of the [Base unit power supplies](#) and the [Control units](#).

Cache backup batteries

The AMS 2100 and AMS 2300 base units include two cache backup batteries. See items #3 and #4 in [Figure 4-1 on page 4-2](#). Two fully charged batteries can preserve the data in the cache for 24 to 72 hours, depending on the size of the cache and the amount of data in it. See [Cache management](#) in Chapter 1 for details.

[Figure 4-4](#) shows the cache backup battery. The front panel on the battery contains an Alarm LED and a Ready LED. The battery includes a lock lever that keeps the battery securely installed in the array and is used to remove the battery when needed.

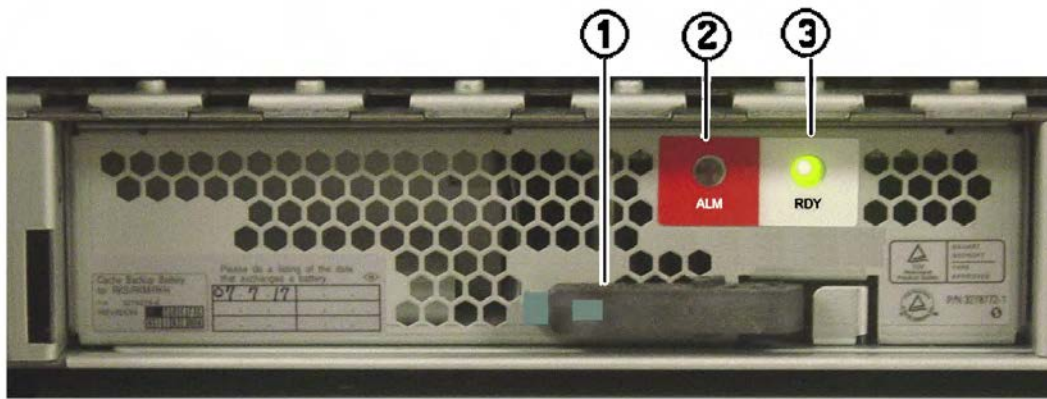

Figure 4-4: Cache Backup Battery

Table 4-4: Cache Backup Battery

Item	Description	Status
①	Lock Lever	When the lock lever is closed and the blue button is fully extended, the battery is secured to the array.
②	Alarm LED (red)	<ul style="list-style-type: none"> When on, indicates that the battery has failed. When off, indicates that the battery status is normal.
③	Ready LED (green)	This LED indicates the condition of the battery. <ul style="list-style-type: none"> On: normal status Low-speed blinking (1 blink per second): The battery is not fully charged. Off or high-speed blinking (8 blinks per second): Abnormal status

Switch panel

The base unit switch panel is located at the lower right corner of the front of the array. See item #5 in [Figure 4-1 on page 4-2](#). The panel contains a power on-off switch and a mode switch, as shown in [Figure 4-5](#).

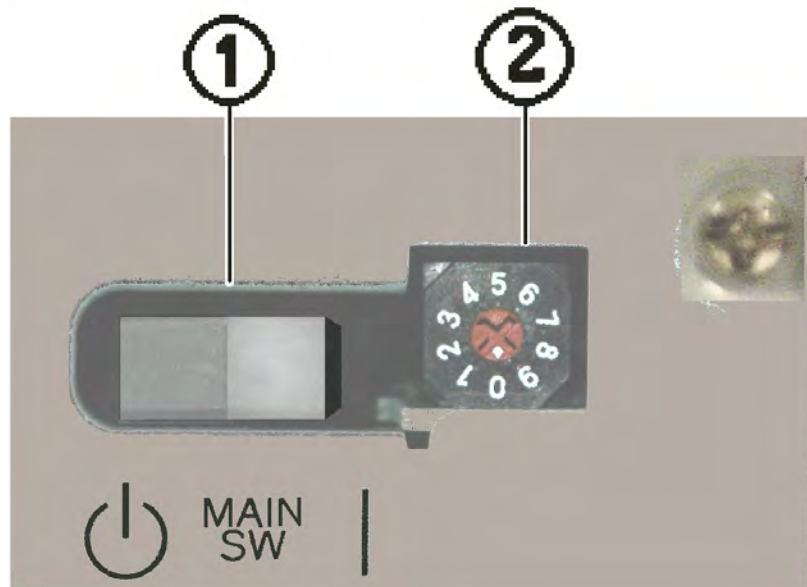

Figure 4-5: Base Unit Switch Panel

Table 4-5: Base Unit Switch Panel

Item	Description
①	<p>Power Switch (labeled Power ON on the front bezel and labeled Main SW on the switch panel).</p> <p>As shown in Figure 4-5, the power ON/OFF switch is labeled MAIN SW.</p> <ul style="list-style-type: none"> • To turn the array power ON, press the right side of the switch (labeled). • To turn the array power OFF, press the left side of the switch.
②	<p>Mode Switch</p> <p>Sets the Uninterruptable Power Supply (UPS) mode to either Local Mode or one of three remote modes. Leave this switch in the local mode (0) position.</p>



NOTE: When you turn the power on, each component in the array automatically runs a power on self test (POST). During this time, the Power LED will be on and the Ready light will be blinking. The POST takes approximately four minutes under normal circumstances. When the POST is complete and the unit is ready for operation, the Ready light changes from blinking to steady ON.

Important! Read chapter 6, Power On and Off Procedures before turning the power on or off.

Base unit rear panel

This section describes the components on the rear panel of both the AMS 2100 and the AMS 2300. While most of the components on the rear panels are the same, some components in the base units are different.

Overview

Figure 4-6 shows the main hardware components on the rear side of a Fibre Channel AMS 2100 base unit. Except for the number of Fibre Channel host connectors on the controllers, the Fibre Channel version of the AMS 2100 rear panel is identical to the AMS 2300. The rear panels of the iSCSI versions of the two models are the same.

The two controllers in each model array are identical and can be installed in either slot. The Fibre Channel and iSCSI controllers for the AMS 2100 and the AMS 2300 are described further on in this chapter.

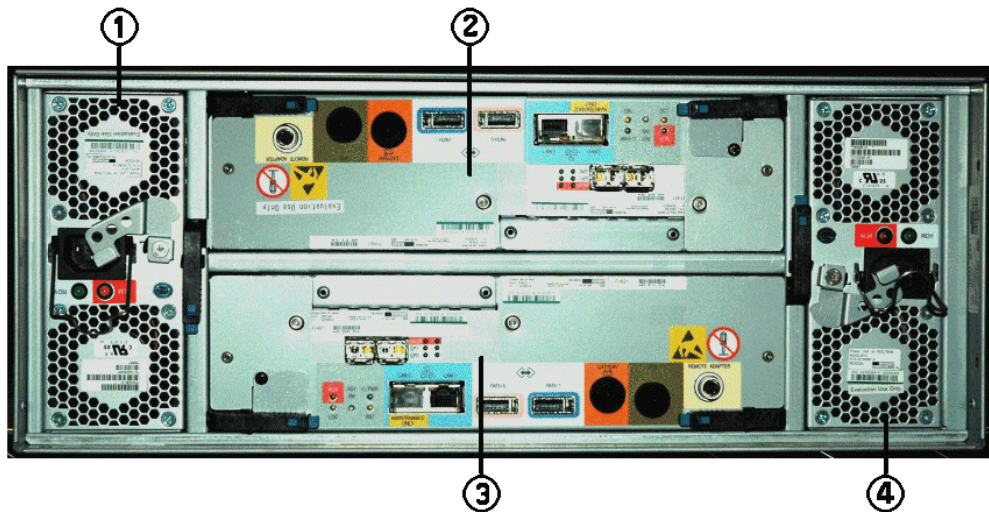

Figure 4-6: AMS 2100 Base Unit Rear Panel Components

Table 4-6: AMS 2100 Base Unit Rear Panel Components

Item	Description	Item	Description
①	Power Supply 0 See Base unit power supplies on page 4-9 for details.	③	Controller 0
②	Controller 1 See Control units on page 4-10 for details.	④	Power Supply 1

Base unit power supplies

As shown in [Figure 4-6](#), the AMS 2100/2300 has two fully redundant power supplies. If one power supply fails, the other one can supply sufficient power and cooling to the array until the failed power supply is replaced.

Power supply status

Each power supply has two LEDs on the panel near the power receptacle. These LEDs indicate the operational status of the power supply, as shown in [Table 4-7](#).

Table 4-7: Base Unit Power Supply LEDs

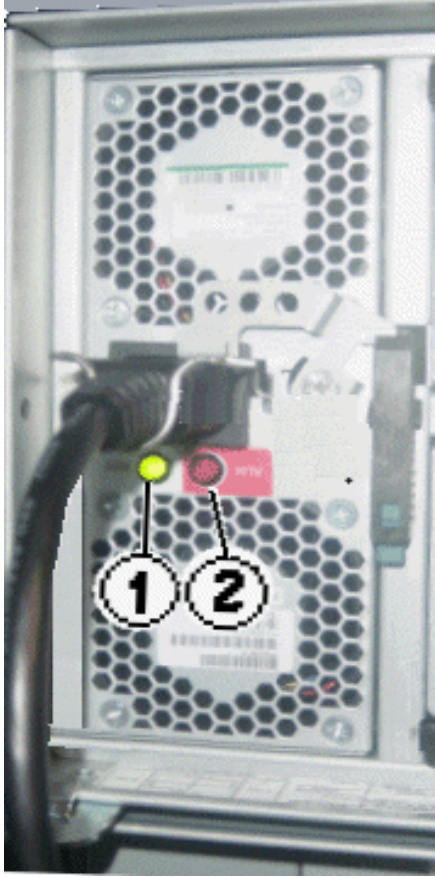
Item	Description
	<p>Ready LED (green).</p> <p>OFF when the power supply is not connected to power.</p> <p>Blinks when the corresponding power receptacle is connected to a working AC outlet, and is running the power on self test (POST).</p> <p>ON when the unit is operational, even if the AMS 2100/2300 array is not turned on.</p>
	<p>Alarm LED (red). This LED indicates that the power supply has failed. Although the other power supply can supply sufficient power and cooling for the array, Hitachi Data Systems recommends that you replace the failed power supply as soon as possible. See the <i>Hitachi AMS 2000 Family Storage System Service Guide</i> for instructions.</p>

Power receptacles

Each power supply contains a power receptacle that must be connected to a working AC power source using the supplied AC power cable.



NOTE: Hitachi Data Systems recommends that each power supply in the base unit be connected to a different AC source in the rack. If one source fails, the other source continues to supply power to the other power supply. This keeps the array running until power is restored to the failed source.

Safety lock

The power supply includes a safety lock. It prevents the lock lever from being opened until the power cable is disconnected from the power supply. This prevents the power supply from being removed from the array with the power applied.

As shown in [Figure 4-7](#), the power supply also includes a power cable retainer that can be used to ensure that the power cable is not accidentally disconnected from the power supply.



NOTE: Hitachi Data Systems recommends that you install the cable retainer to prevent the power cable from accidentally being disconnected from the power supply.

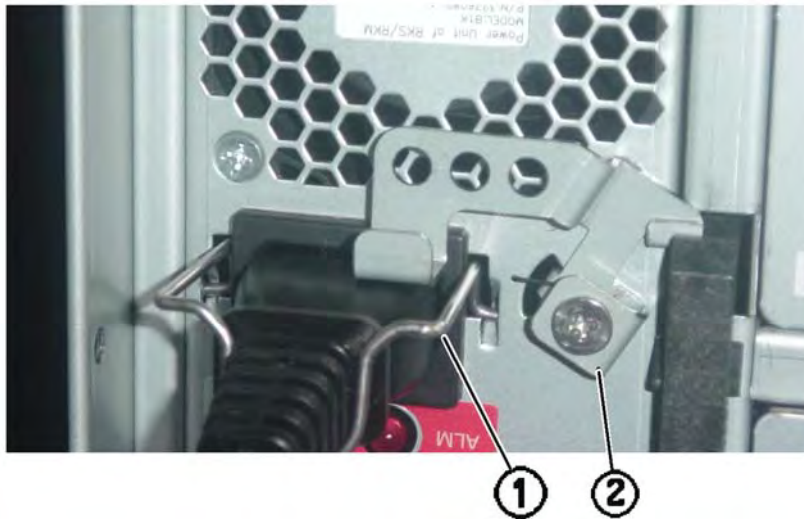

Figure 4-7: Base Unit Power Supply Safety Components

Table 4-8: Base Unit Power Supply Safety Components

Item	Description	Item	Description
①	Power Cable Retainer	②	Safety Lock

Control units

The control units are multifunction devices that provide connection and management functions for the array, including:

- Connecting the base unit to a host computer
- Connecting the base unit to an expansion unit
- Connecting the base unit to a management console
- Managing the storage, replication, and security of data from the host computer to the disk drives
- Storing and supporting the array firmware (operating system) and the Navigator 2 storage management software

AMS 2100 Fibre channel control unit

As described earlier, the controllers in each model base unit are different. The main differences between the control units is the number of Fibre Channel ports and the amount of cache memory (RAM) installed in the control units. [Figure 4-8](#) shows the lower control unit of an AMS 2100 /RKS base unit. The upper control unit is identical but is installed in the base unit upside down.

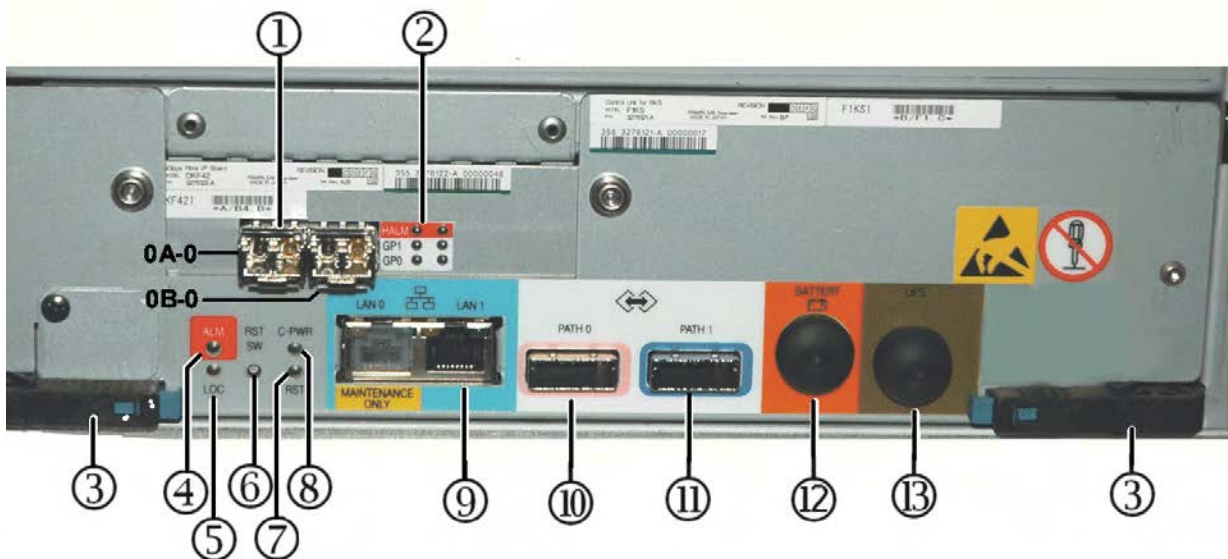

Figure 4-8: Control Unit Connectors and LEDs (Fibre Channel AMS 2100)

Table 4-9: Control Unit Connectors and LEDs (Fibre Channel AMS 2100)

Item	Description	Item	Description	Item	Description
①	Fibre channel host connectors (2 per controller)	⑥	Reset Button Resets the control unit and performs a full dump.	⑩	ENC Connector 0 IN (Path 0)
②	Fibre Channel HALM (Host Alarm) - indicates that the host connector is abnormal. GP0 LED/GP1 LEDs (green) - indicate that the interface is normal.	⑦	Reset LED (orange) Blinks while the control unit is resetting	⑪	ENC Connector 1 IN (Path 1)
		⑧	C- Power LED (green) When on, indicates that cache memory is backed up.	⑫	Battery Expansion Unit Connector (not supported)
③	Lock Lever (2 places)	⑨	Left connector Maintenance (LAN 0)	⑬	Uninterruptible Power Supply Connector
④	Alarm LED (red) Indicates that the control unit has failed.		Right connector: 10/100 Ethernet management port (LAN 1)		
⑤	LOC LED (orange) See Table 4-16 on page 4-21		ACT LED (yellow) indicates data is being transferred. LINK LED (green) When ON, indicates that the link status is normal.		

The AMS 2100 supports uninterrupted power supplies (UPS). The connector location may differ slightly, depending on controller revision. Please contact your Hitachi Data Systems representative for supported UPS models. Refer to the UPS documentation for implementation details.

AMS 2100 Rev1 Fibre channel control unit RKS

As described earlier, the controllers in each model base unit are different. The main differences between the control units is the number of Fibre Channel ports and the amount of cache memory (RAM) installed in the control units. Figure 4-9 shows the lower control unit of an AMS 2100 Rev1/ RKS base unit. The upper control unit is identical but is installed in the base unit upside down.

- Control Unit(RKS)

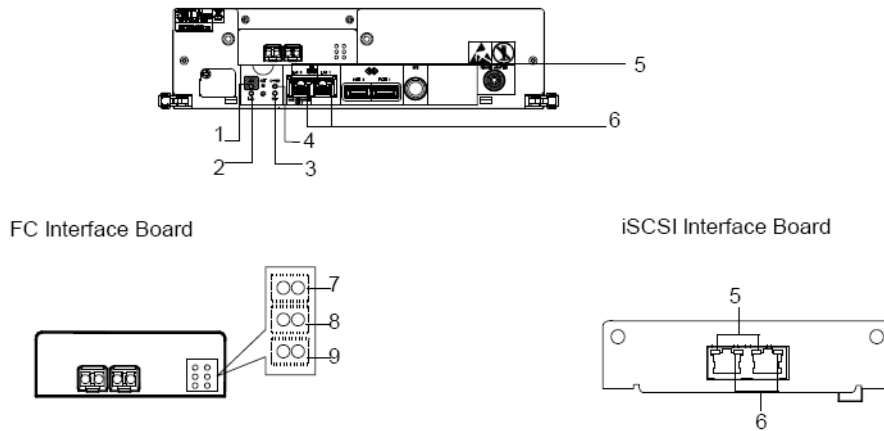

Figure 4-9: AMS 2100 Rev1 Disk Drive Status LEDs

Table 4-10: AMS 2100 Rev1 Base Unit Status LEDs (front panel)

Item	LED	Function
1	Alarm (red)	Lights when the drive has a failure in the control unit.
2	LOC (orange)	When adding the chassis with the power turned on, indicates the addition source (not an error). Determine the type of error by the number of times the LED blinks. <ul style="list-style-type: none"> • Not blinking: Boot section error of ENC microprogram, RAM error, or ENC hard configuration error. • 1: SRAM error • 2: ENC hard error • 3: Microprogram error in flash memory • 4: CUDG error in ENC • 6: Voltage on the control unit is abnormal. Reset of the control unit is not canceled.
3	RST (orange)	ON: control unit is resetting.
4	C-PWR (green)	ON: cache memory is backed up.

Item	LED	Function
5	ACT/Active (yellow)	ON: data is being transferred.
6	LINK (green)	ON: link status is normal.
7	HALM	ON: host connector is abnormal.
8	GP1 (green)	ON: status of the interface is abnormal.
9	GP0 (green)	ON: status of the interface is normal.

AMS 2100 Rev2 Fibre channel control unit RKES

As described earlier, the controllers in each model base unit are different. The main differences between the control units is the number of Fibre Channel ports and the amount of cache memory (RAM) installed in the control units. Figure 4-10 and Table 4-11 shows the lower control unit of an AMS 2100 Rev2 /RKES base unit. The upper control unit is identical but is installed in the base unit upside down.

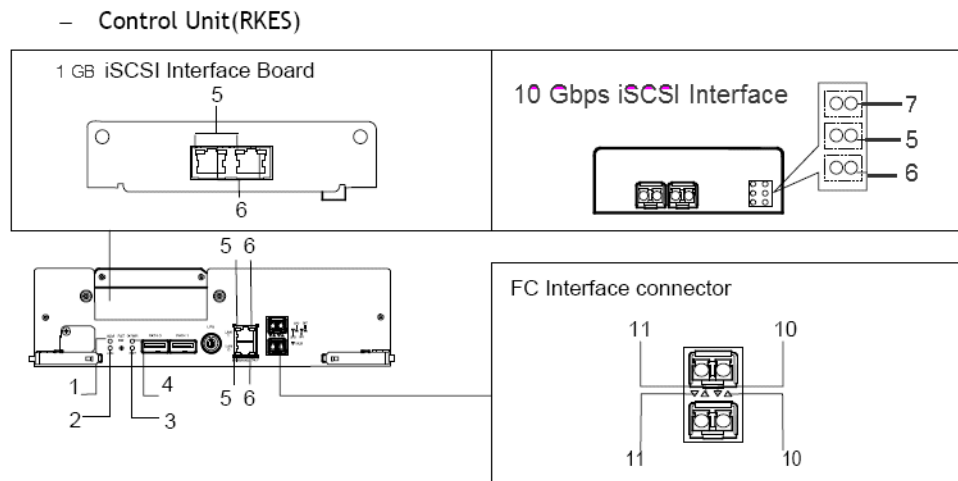

Figure 4-10: RKES Disk Drive Status LED

Table 4-11: RKES Disk Drive Status LEDs (front panel)s

Item	LED	Function
1	Alarm (red)	Lights when the drive has a failure in the control unit.

Item	LED	Function
2	LOC (orange)	<p>When adding the chassis with the power turned on, indicates the addition source (not an error).</p> <p>Determine the type of error by the number of times the LED blinks.</p> <ul style="list-style-type: none"> • Not blinking: Boot section error of ENC microprogram, RAM error, or ENC hard configuration error. • 1: SRAM error • 2: ENC hard error • 3: Microprogram error in flash memory • 4: CUDG error in ENC • 6: Voltage on the control unit is abnormal. Reset of the control unit is not canceled.
3	RST (orange)	ON: control unit is resetting.
4	C-PWR (green)	ON: cache memory is backed up.
5	ACT/Active (yellow)	ON: data is being transferred.
6	LINK (green)	ON: link status is normal.
7	HALM	ON: host connector is abnormal.
8	GP1 (green)	ON: status of the interface is normal.
9	GP0 (green)	ON: status of the interface is normal.
10	GP1 (red)	ON: status of the interface is normal.
11	GP0 (red)	ON: the host connector is abnormal (GP0 LED and GP1 LEDs become red at the same time).

AMS 2300 Fibre Channel control unit

As described earlier, the controllers in each model base unit are different. The main differences between the control units is the number of Fibre Channel ports and the amount of cache memory (RAM) installed in the control units. [Figure 4-11](#) shows the lower control unit (#0) of an for the AMS 2300 /RKS base unit. The upper control unit (#1) is identical but is installed in the base unit upside down.

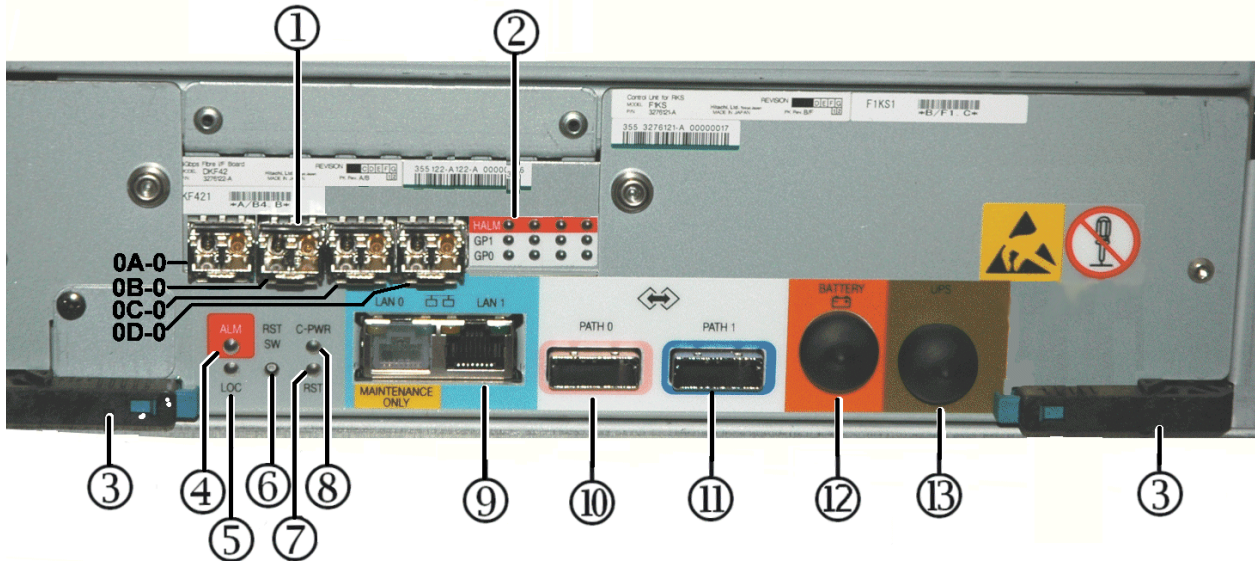

Figure 4-11: Control Unit Connectors and LEDs (Fibre Channel AMS 2300)

Table 4-12: Control Unit Connectors and LEDs (Fibre Channel AMS 2300)

Item	Description	Item	Description	Item	Description
①	Fibre channel host connectors (4 per controller)	⑥	Reset Button Resets the control unit and performs a full dump.	⑩	ENC Connector 0 IN (Path 0)
②	Fibre Channel HALM (Host Alarm) - indicates that the host connector is abnormal. GP0 LED/GP1 LEDs (green) - indicate that the interface is normal.	⑦	Reset LED (orange) Blinks while the control unit is resetting	⑪	ENC Connector 1 IN (Path 1)
③	Lock Lever (2 places)	⑧	C- Power LED (green) When on, indicates that cache memory is backed up.	⑫	Battery Expansion Unit Connector (not supported)
④	Alarm LED (red) Indicates that the control unit has failed.	⑨	Left connector Maintenance (LAN 0)	⑬	Uninterruptible Power Supply Connector ¹
⑤	LOC LED (orange) See Table 4-16 on page 4-21		Right connector:: 10/100 Ethernet management port (LAN 1)		
			ACT LED (yellow) indicates data is being transferred. LINK LED (green) When ON, indicates that the link status is normal.		

1. Fibre Channel AMS 2300 supports uninterrupted power supplies (UPS). The location of this connector may be slightly different than shown here, depending on the model of the controller. For more information, contact your Hitachi Data Systems representative, or refer to the UPS documentation.

AMS 2300 Rev2 Fibre channel control unit RKM

As described earlier, the controllers in each model base unit are different. The main differences between the control units is the number of Fibre Channel ports and the amount of cache memory (RAM) installed in the control units. Figure 4-12 and Table 4-13 shows the lower control unit of an AMS 2300 Rev2 /RKM base unit. The upper control unit is identical but is installed in the base unit upside down.

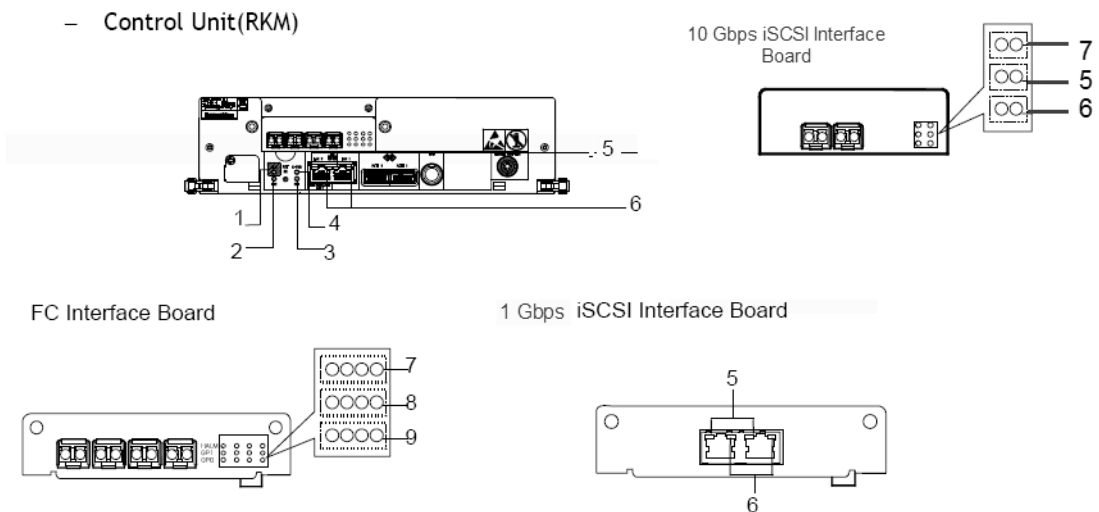

Figure 4-12: AMS 2300 RKM LEDs

Table 4-13: AMS 2300 RKM LEDs

Item	LED	Function
1	Alarm (red)	Lights when the drive has a failure in the control unit.

Item	LED	Function
2	LOC (orange)	<p>When adding the chassis with the power turned on, indicates the addition source (not an error).</p> <p>Determine the type of error by the number of times the LED blinks.</p> <ul style="list-style-type: none"> • Not blinking: Boot section error of ENC microprogram, RAM error, or ENC hard configuration error. • 1: SRAM error • 2: ENC hard error • 3: Microprogram error in flash memory • 4: CUDG error in ENC • 6: Voltage on the control unit is abnormal. Reset of the control unit is not canceled.
3	RST (orange)	ON: the control unit is resetting.
4	C-PWR (green)	ON: cache memory is backed up.
5	ACT/Active (yellow)	ON: data is being transferred.
6	LINK (green)	ON: the link status is normal.
7	HALM	ON: the host connector is abnormal.
8	GP1 (green)	ON: the status of the interface is normal.
9	GP0 (green)	ON: the status of the interface is normal.

AMS 2300 Rev2 Fibre channel control unit RKEM

As described earlier, the controllers in each model base unit are different. The main differences between the control units is the number of Fibre Channel ports and the amount of cache memory (RAM) installed in the

control units. [Figure 4-13](#) and [Table 4-14](#) shows the lower control unit of an AMS 2100 /RKES base unit (Rev2). The upper control unit is identical but is installed in the base unit upside down.

Figure 4-13: AMS 2300 Rev2 RKEM LEDs

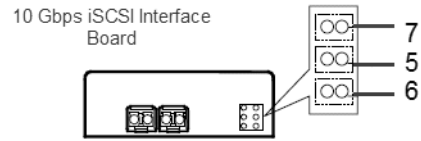

- Control Unit(RKEM)

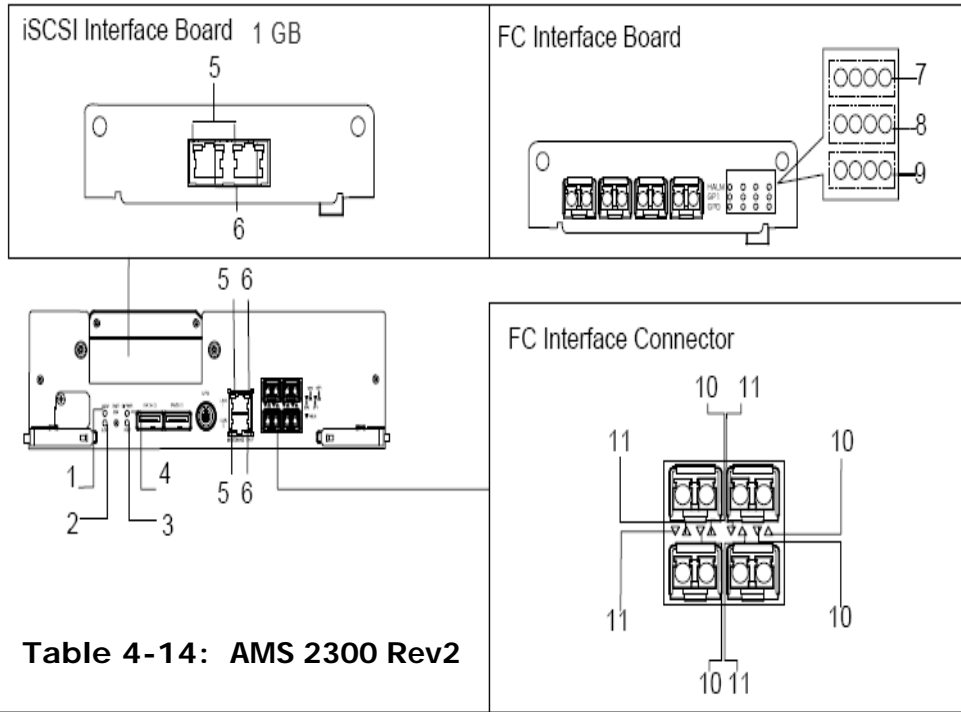

Table 4-14: AMS 2300 Rev2

RKEM LEDs

Item	LED	Function
1	Alarm (red)	Lights when the drive has a failure in the control unit.

Item	LED	Function
2	LOC (orange)	<p>When adding the chassis with the power turned on, indicates the addition source (not an error).</p> <p>Determine the type of error by the number of times the LED blinks.</p> <ul style="list-style-type: none"> • Not blinking: Boot section error of ENC microprogram, RAM error, or ENC hard configuration error. • 1: SRAM error • 2: ENC hard error • 3: Microprogram error in flash memory • 4: CUDG error in ENC • 6: Voltage on the control unit is abnormal. Reset of the control unit is not canceled.
3	RST (orange)	ON: control unit is resetting.
4	C-PWR (green)	ON: cache memory is backed up.
5	ACT/Active (yellow)	ON: data is being transferred.
6	LINK (green)	ON: link status is normal.
7	HALM	ON: host connector is abnormal.
8	GP1 (green)	ON: status of the interface is normal.
9	GP0 (green)	ON: status of the interface is normal.
10	GP1 (red)	ON: status of the interface is normal.
11	GP0 (red)	ON: the host connector is abnormal (GP0 LED and GP1 LEDs become red at the same time).

AMS 2100/2300 iSCSI control unit

The iSCSI AMS 2100/2300 control units are externally the same and are shown in the following illustration. The only difference between them is the amount of RAM (cache memory) each contains. See [Cache management on page 1-19](#) for details about the cache options.

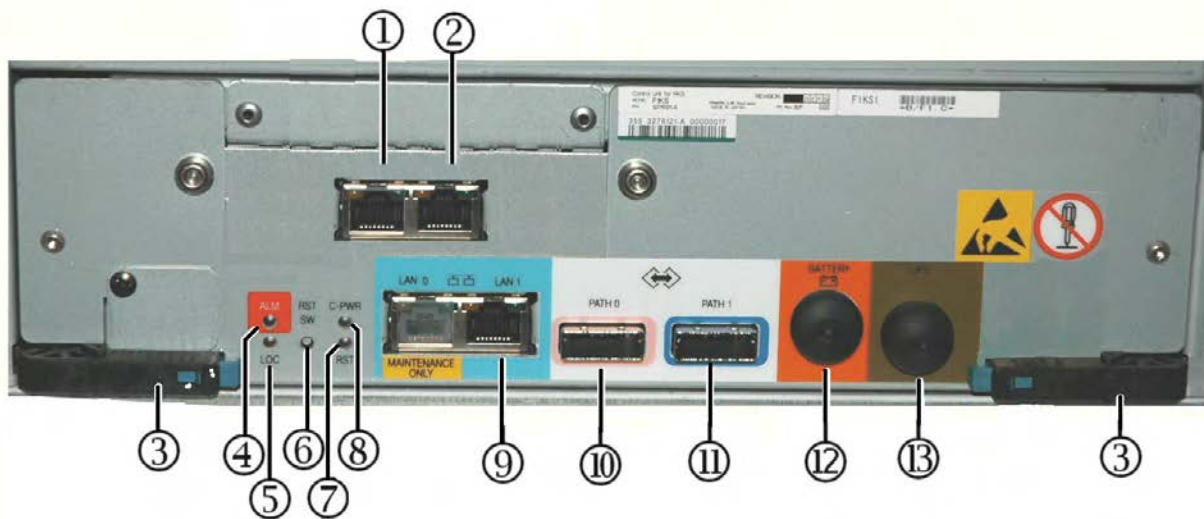

Figure 4-14: AMS 2100/2300 iSCSI Control Unit

Table 4-15: AMS 2100/2300 iSCSI Control Unit

Item	Description	Item	Description	Item	Description
①	iSCSI RJ45 Port #0 See item 9 for ACT and Link LED descriptions	⑦	Reset LED ((orange)) Blinks while the base unit is resetting	⑩	ENC Connector 0 IN (Path 0)
②	iSCSI RJ45 Port #1 See item 9 for ACT and Link LED descriptions	⑧	C- Power LED (green) When on, indicates that cache memory is backed up.	⑪	ENC Connector 1 IN (Path 1)
③	Lock Lever (2 places)	⑨	Left connector: Maintenance (LAN 0) Right connector: 10/100 Ethernet management port (LAN 1) ACT LED (yellow) indicates data is being transferred. LINK LED (green) When ON, indicates that the link status is normal.	⑫	Battery Expansion Unit Connector (not supported)
④	Alarm LED (red) Indicates that the control unit has failed.			⑬	Uninterruptable Power Supply Connector ¹
⑤	LOC LED ((orange)) See LOC LED on page 4-21			⑭	Remote Adapter connector ¹
⑥	Reset Button Resets the control unit and performs a full dump.				

1. AMS 2100/2300 iSCSI supports uninterrupted power supplies (UPS). The location of this connector may be slightly different than shown here, depending on the model of the controller. For more information, contact your Hitachi Data Systems representative, or refer to the UPS documentation.

LOC LED

The (orange) LOC (locate) LED indicates various controller conditions depending on the speed and number of blinks, as described in [Table 4-16](#). See [Chapter 8, Troubleshooting](#) to solve indicated problems and/or call Hitachi Data Systems Technical Support for help.

Table 4-16: LOC LED

Number of blinks	Description
6 (slow)	Voltage on the control unit is abnormal. (Reset of the control unit is not canceled)
1 (fast) ¹	SRAM error.
2 (fast)	ENC hard error.
3 (fast)	Firmware error in flash memory.
4 (fast)	ENC firmware has detected a CUDG error in the ENC unit.
ON	Boot section error in the ENC firmware, a RAM error, or ENC hard configuration error.

1. When blinking fast, the LED is on for 400ms and off for 200 ms for each fast blink. After the number of fast blinks has completed, the LED is off for one second.

Fibre channel host connectors

Each of the two AMS 2100 control units has two Fibre Channel data ports (total of 4 ports per array). Each of the two AMS 2300 control units has four Fibre Channel data ports (total of 8 ports per array). Each data port is part of a device called a host connector. A host connector is a SFP (Small Form factor Pluggable) optical transceiver that connects the Fibre Channel interface board inside the control unit to the fibre optic cables.

The following illustrations show the four Fibre Channel data ports / Host Connectors on an AMS 2300 control unit.

- Photograph ① shows the leftmost host connector with the lock opened and the unit ready for removal. The second connector is shown capped, as all of the host connectors are when the array is shipped. The third and fourth ports are shown connected. Note that two types of Fibre Channel cables and connectors are used in this photo.
- Photograph ② shows a close up view of the two connectors in each data port.
- Photograph ③ shows a host connector partially removed from the array.
- Photograph ④ shows a host connector completely removed from the array. The front bezel key is included in the photo to show the relative size of a host connector.

See the *Hitachi AMS 2000 Family Storage System Service Guide* for information and instructions to remove and replace a host connector.

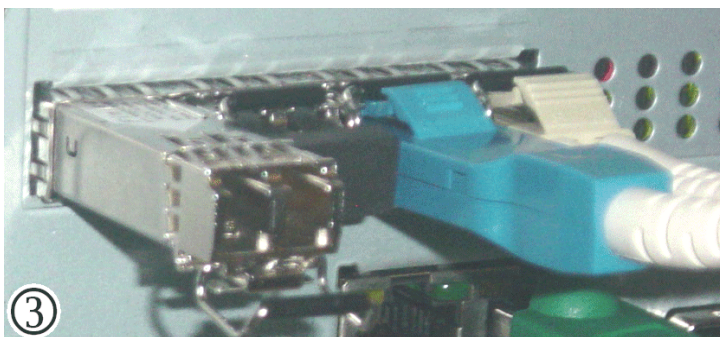
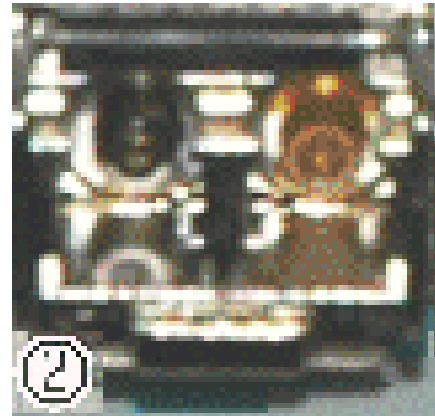
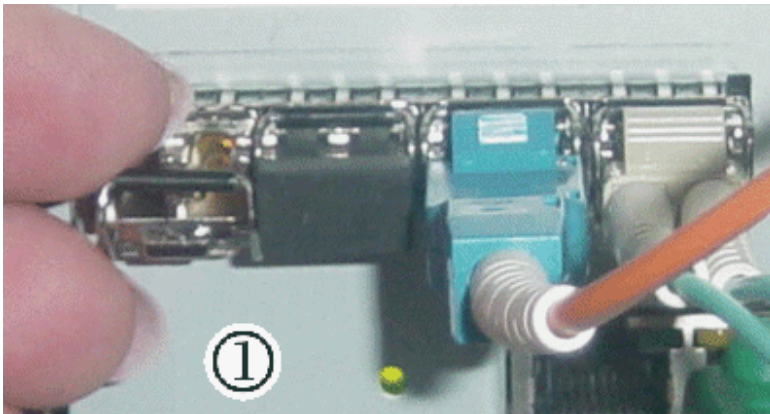

Figure 4-15: Fibre Channel Host Connectors

10/100 Ethernet management port

Each AMS 2100/2300 controller has one 10/100BaseT Ethernet management port that is used to connect the control unit to a management console, usually a laptop PC. It can be connected directly or via a Local Area Network (LAN). The management port accepts either a cross-over cable for direct connections to the management port or a straight-through cable if connecting to the management port through a switch.

Using the management console, you can configure and manage an AMS 2100/2300 array using the Navigator 2 storage management software on the CD that is supplied with the hardware. You can also use the storage features described under [Features and benefits on page 1-11](#) to interact with an AMS 2100/2300 array.

The management port accepts either a cross-over cable for direct connections to the management port or a straight-through cable if connecting to the management port through a switch. The port is a standard RJ45 connector that has an amber Port Activity LED on the left side of the port and a (green) Link LED on the right side. When an active LAN cable is plugged into the port, the Link light comes on steady. The Activity LED lights when data is being transferred to or from the port.



NOTE: If you use Navigator 2 to configure an AMS 2100/2300 array to send email alerts, be sure the management port can communicate via Ethernet with your mail server. For more information, refer to the Navigator 2 online help.

The following illustration shows an example of how a laptop might be connected to a base unit that is installed in a rack.

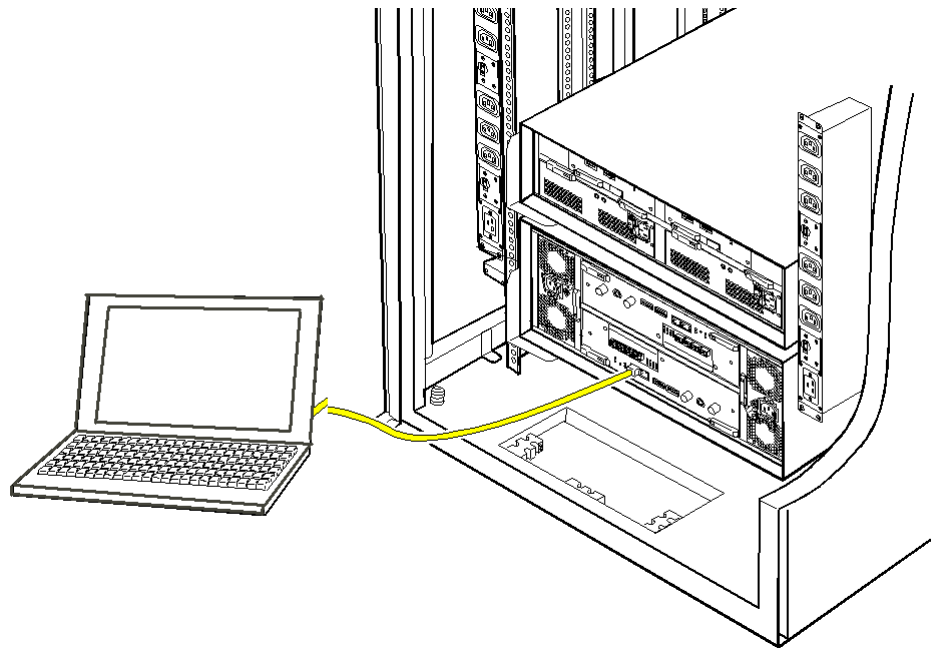

Figure 4-16: Connecting a Laptop to a Management Port

Standard expansion unit

A standard expansion storage unit (RKAK) provides additional storage capabilities for the base units. An expansion unit can hold from 2 to 15 SATA or SAS drives. SATA and SAS drives can be mixed within the same enclosure, so long as the guidelines under [Disk drive configurations on page 4-3](#) and [RAID implementations on page 1-22](#) are followed.

Both the AMS 2100 and the AMS 2300 base units use the same expansion unit, although the number of expansion units that they can use is different.

- An AMS 2100 base unit supports up to seven expansion units.
- An AMS 2300 base unit supports up to fifteen expansion units.

Drives are installed, removed, and replaced from the front of the expansion unit. No tools are required.

Expansion unit (RKAK) front panel

The following illustration shows the front of an expansion unit (factory designation RKAK) with the decorative bezel installed.

The front panel of the expansion unit includes Power and Locate status LEDs that show the status of the unit and identify the unit. The installation location should provide an unobstructed view of these LEDs.

In addition, each drive slot on the expansion unit has alarm and Active LEDs that show the status of the drive that is installed in the slot that is directly below the status LEDs. As shown in [Figure 4-18 on page 4-26](#), these LEDs are visible when the front bezel is removed. A close up photo of the drive status LEDs is shown in [Figure 4-2 on page 4-3](#).

There are no switches on an expansion unit. Power is turned on and off with a control signal that is routed from the base unit via the ENC cables that are connected to the ENC unit in the expansion unit.



Figure 4-17: Front View of an Expansion Unit

Table 4-17: Expansion Unit Front View

Item	Description	Item	Description
①	Locate LED - Indicates that a failure which does not stop operation occurred in unit. (orange)	②	Power LED (green)

The following illustration shows the front of an expansion unit (factory designation RKAK) with the decorative bezel removed and the disk drives in the front of the array exposed.

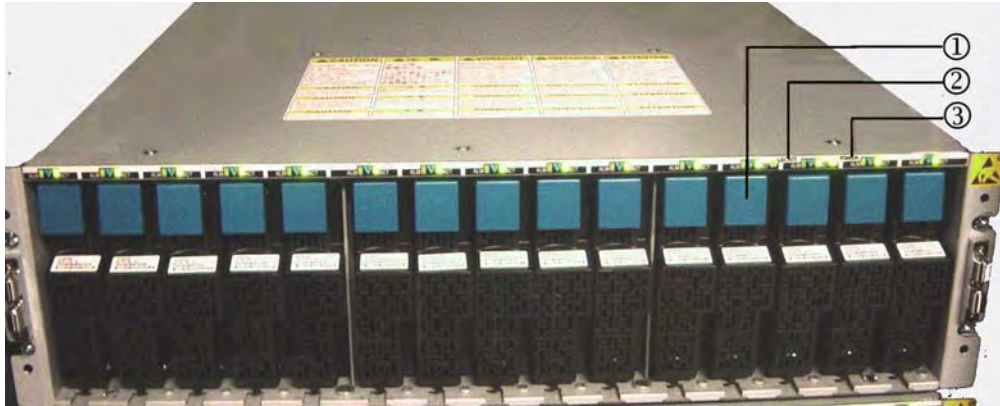

Figure 4-18: Expansion Unit Front View

Table 4-18: Expansion Unit Front View

Item	Description	Item	Description	Item	Description
①	Disk Drives, showing the status LEDs ¹	②	Locate LED	③	Power LED

1. Enlarged views are shown on pages 4-18 and 4-19.

Disk drives

As shown in #1 in Figure 4-11 above, an AMS 2100/2300 expansion unit has 15 drive slots in the front of the array. Each slot can accommodate one SATA drive or one SAS drive.

Disk drive configurations

The following requirements are for the expansion unit as well as for both the AMS 2100 and the AMS 2300 base units.

- The minimum number of drives that must be installed in the base unit is four.
- The first four drives that are installed must be either all SAS drives or all SATA drives.
- After the minimum configuration is met, you can add two SAS or two SATA drives (which makes a RAID1 configuration), or other combinations of drives as required to meet the RAID configurations specified in Chapter 1.

Disk drive status LEDs

The expansion unit has two LEDs that are built into the unit chassis above each disk drive slot. These LEDs, which are shown in the following figure, indicate the status of the drive that is installed in the slot below them.

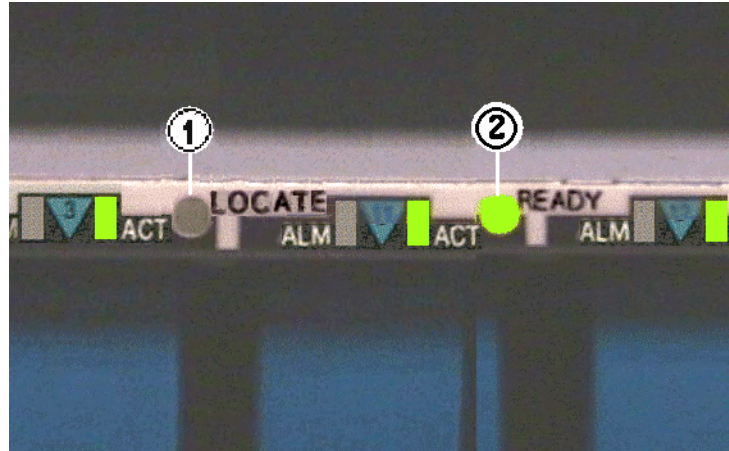

Figure 4-19: Disk Drive Status LEDs

Table 4-19: Disk Drive Status LEDs

Item	Description	Item	Description
①	ALarM LED (red) Lights when the drive has a serious error.	②	ACTive LED (green) Lights or flashes when the drive is operating and is being read from or written to. It indicates that the disk drive is operational.

Expansion unit status LEDs

The upper right edge of the front of the AMS 2100/2300 expansion unit contains two LEDs that indicate the status of the unit. The table below describes the array status LEDs and their functions.

Table 4-20: Expansion Unit Status LEDs

Item	Name/ Color	Status	Description
①	LOCATE (orange)	OFF	Normal operation
		ON	A serious error has occurred in the unit. Please contact Hitachi Data Systems Technical Support. See the Getting Help section in the Preface of this manual.
②	POWER (green)	ON	Normal operation; the section is fully operational.
		Slow Blink	The firmware download is complete.
		Fast Blink	The firmware is downloading (do not turn off the array).

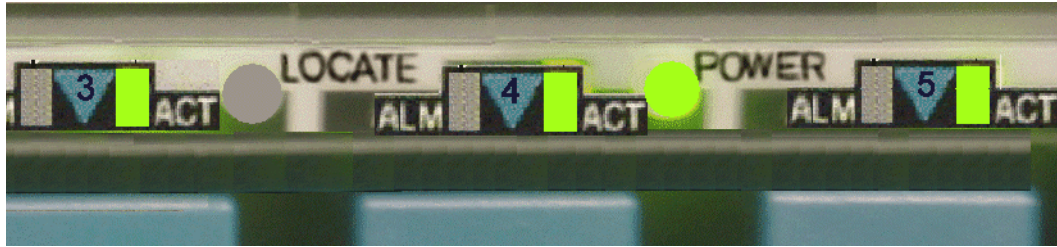

Expansion unit rear panel

This section describes the components on the rear Panel of the expansion unit. [Figure 4-20](#) shows the key hardware components on the rear panel of an AMS 2100/2300 expansion unit.

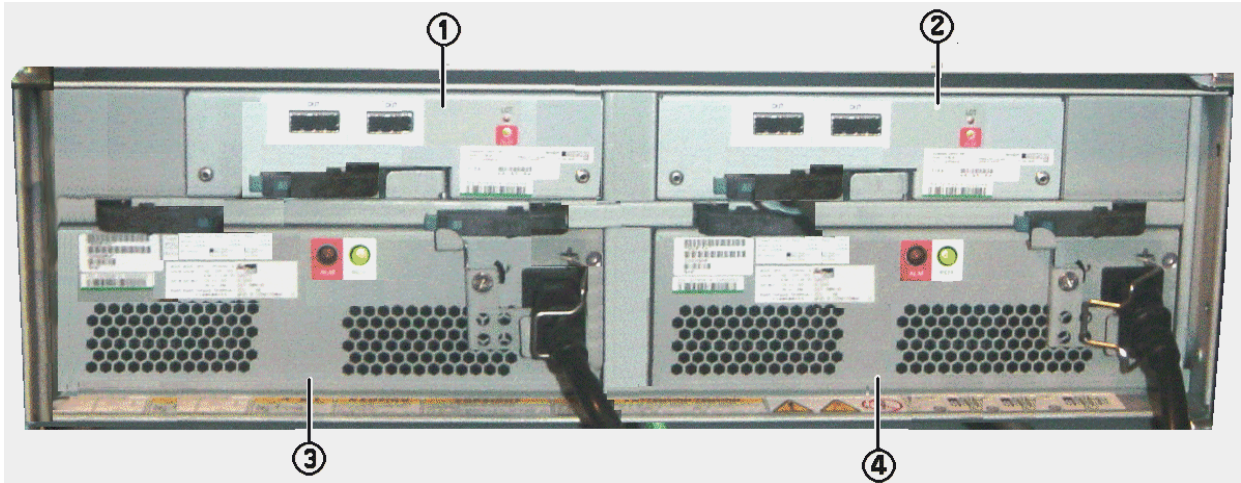

Figure 4-20: Expansion Unit Rear Panel Components

Table 4-21: Expansion Unit Rear Panel Components

Item	Description	Item	Description
①	ENC Unit 0	③	Power Supply 0
②	ENC Unit 1	④	Power Supply 1

The rear of the expansion unit provides the connectors used to daisy chain expansion units in the system. See [Chapter 5, Installation](#) for details. It also provides LEDs that show the status of the expansion unit and the power supplies that provide power to the expansion unit. Expanded views of the expansion unit and detailed descriptions are located on the following pages.

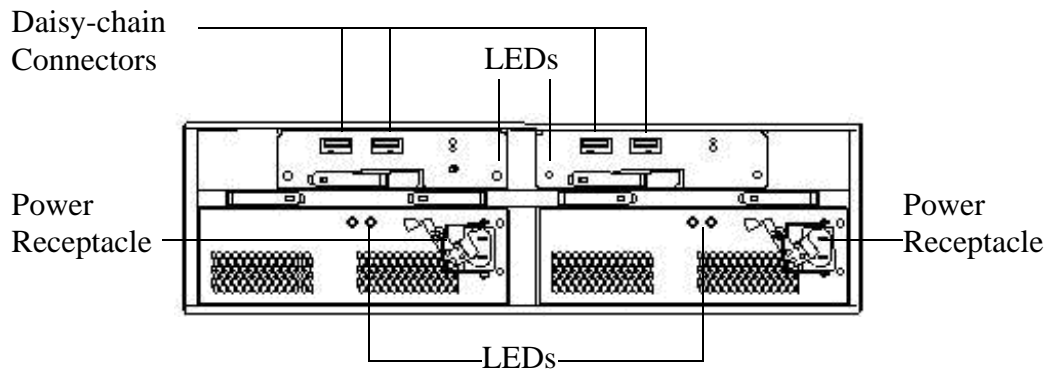

Figure 4-21: Rear View of the Expansion Unit

Expansion unit power supply

As shown in [Figure 4-20](#), the expansion unit has two fully redundant power supplies. If one power supply fails, the other one can supply sufficient power and cooling to the array until the failed power supply is replaced.

Power supply status

As shown in [Figure 4-22](#), Each power supply has two LEDs on the panel near the power receptacle. These LEDs indicate the operational status of the power supply, and are described in [Table 4-22](#).

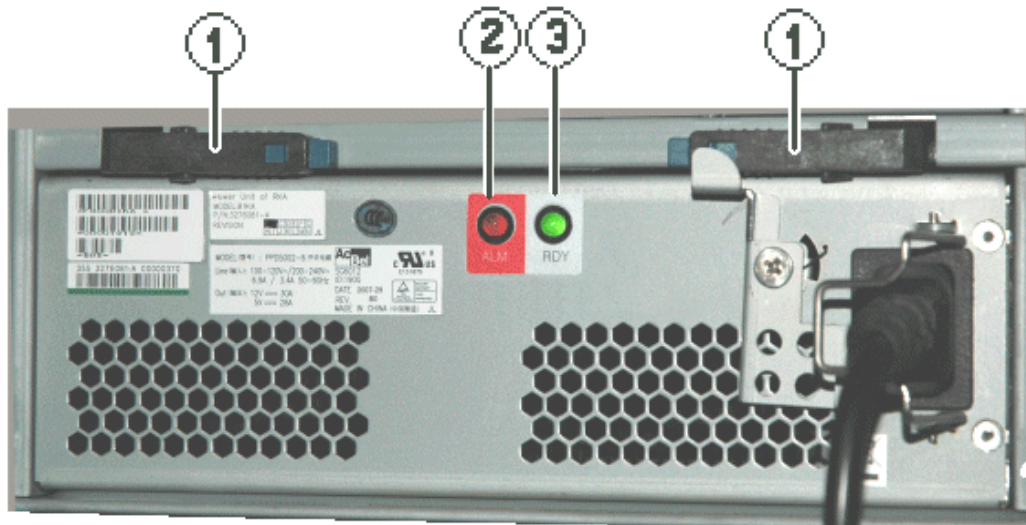

Figure 4-22: Expansion Unit Power Supply Components

Table 4-22: Expansion Unit Power Supply Components

Item	Description
①	Lock Lever (2 places)
②	Alarm LED (red). This LED indicates that the power supply has failed. Although the other power supply can supply sufficient power and cooling for the expansion array, Hitachi Data Systems recommends that you replace the power supply as soon as possible. See the <i>Hitachi AMS 2000 Family Storage System Service Guide</i> for instructions.
③	Ready LED (green). on each power supply blinks when the corresponding power receptacle is connected to a working AC outlet, even if an AMS 2100/2300 array is not turned on; otherwise, the LED is OFF.

Power receptacles

Each power supply contains a power receptacle that must be connected to a working AC power source using the supplied AC power cable.



NOTE: Hitachi Data Systems recommends that each power supply in the base unit be connected to a different AC source in the rack. If one source fails, the other source continues to supply power to the other power supply. This keeps the array running until power is restored to the failed source.

Safety lock

Like the base unit, the expansion unit power supply includes a safety lock that prevents the lock lever from being opened until the power cable is disconnected from the power supply. This prevents the power supply from being removed from the array with the power applied.

As shown in [Figure 4-23](#), the power supply also includes a power cable retainer that can be used to ensure that the power cable is not accidentally disconnected from the power supply.



NOTE: Hitachi Data Systems recommends that you install the cable retainer to prevent the power cable from accidentally being disconnected from the power supply.

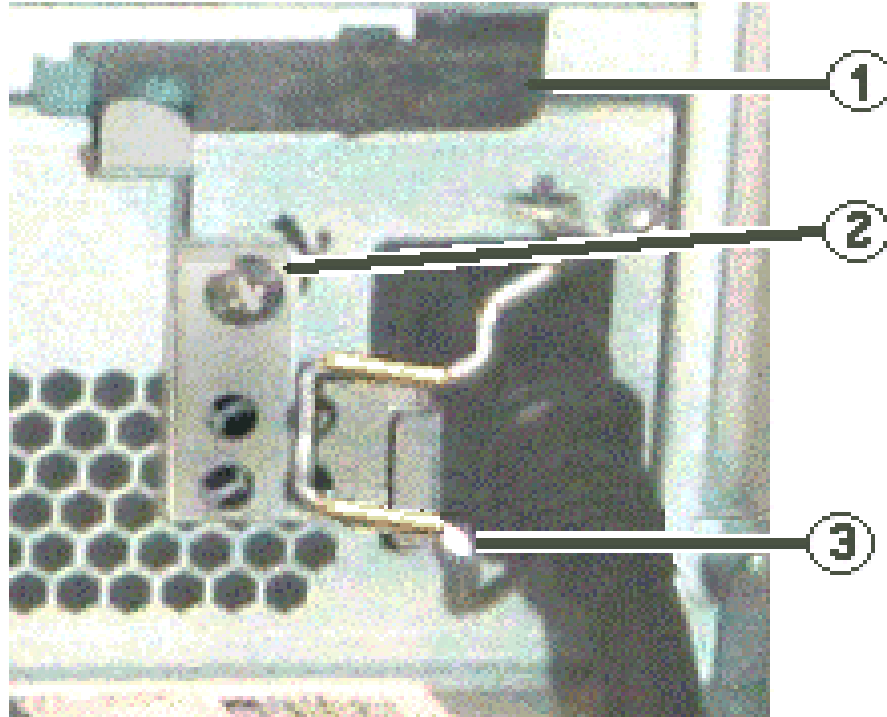

Figure 4-23: Expansion Unit Power Supply Safety Components

Table 4-23: Expansion Unit Power Supply Safety Components

Item	Description	Item	Description	Item	Description
①	Lock Lever	②	Safety Lock	③	Power Cable Retainer

ENC unit RKAK

The ENC unit is mounted in the expansion unit. It is the interface between the expansion unit in which it is mounted and the controller in a base unit or the ENC unit in another expansion unit. The ENC unit is shown in [Figure 4-24](#).

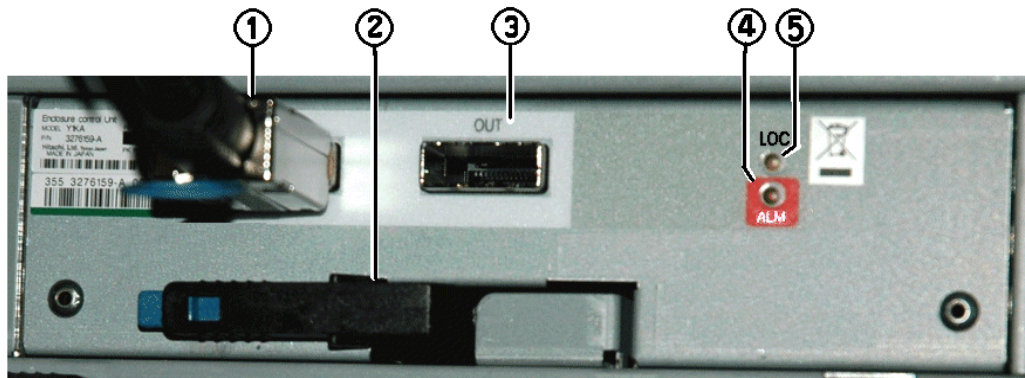

Figure 4-24: Expansion Unit ENC Unit

Table 4-24: Expansion Unit ENC Unit

Item	Description	Item	Description
①	ENC Port (IN) from either a base unit or an expansion unit or high-density expansion unit. Shown with an ENC cable connected to it.	④	Alarm LED (red) This LED indicates that the ENC unit has failed.
②	Lock Lever	⑤	LOC LED (orange) See Table 4-25 below.
③	ENC Port (OUT) to a base unit, expansion unit, or high-density expansion unit.		

Table 4-25: LOC LED

Number of blinks	Description
6 (slow)	Voltage on the control unit is abnormal. (Reset of the control unit is not canceled)
1 (fast) ¹	SRAM error.
2 (fast)	ENC hard error.
3 (fast)	Firmware error in flash memory.
4 (fast)	CUDG error in ENC.
ON	Boot section error in the ENC firmware, a RAM error, or ENC hard configuration error.

1. When blinking fast, the LED is on for 400ms and off for 200 ms for each fast blink. After the number of fast blinks has completed, the LED id off for one second.

Modular 2U SAS expansion unit

A **modular 2U SAS expansion unit** (factory designation RKAKS) provides additional storage capabilities for the base units. For the AMS 2100 and the AMS 2300, this unit can install a maximum of 24 SAS disk drives. An expansion unit provides additional storage space and can connect the base unit to additional expansion units or high-density expansion units. The same expansion unit is used with both base unit models.

An expansion unit contains two redundant power supplies, two ENC interface units, and from two to 24 disk drives

Modular 2U SAS expansion unit front panel

Figure 4-25 shows the front of an expansion unit (factory designation RKAKS) with the decorative bezel installed.

The front panel of the expansion unit includes Power and Locate status LEDs that show the status of the unit and identify the unit. The installation location should provide an unobstructed view of these LEDs. The function of the LEDs is shown in Table 4-26.

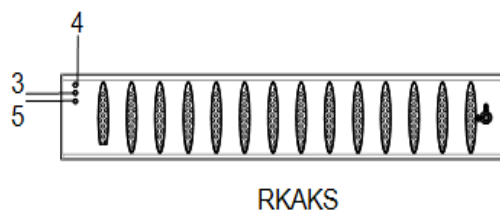

Figure 4-25: RKAKS front panel LEDs

Table 4-26: RKAKS front panel LEDs

Number	LED	Function
3	READY LED (green)	ON: The subsystem can be operated. BLINKING: High-speed: The internal processing is executed (even if the READY LED blinks, the subsystem is operational.) Low Speed blinking: The offline download processing ended (this is displayed during the maintenance work.)
4	POWER LED (green)	ON: Power is supplied to the subsystem.
5	LOCATE LED (orange)	ON: A failure which does not stop operation occurred in the unit. When adding the chassis with the power turned on, it indicates the addition source (this is not an error).

Modular 2U SAS expansion unit disk drive LEDs

Figure 4-26 and Table 4-27 show and describe the disk drive display status LEDs and their functions.

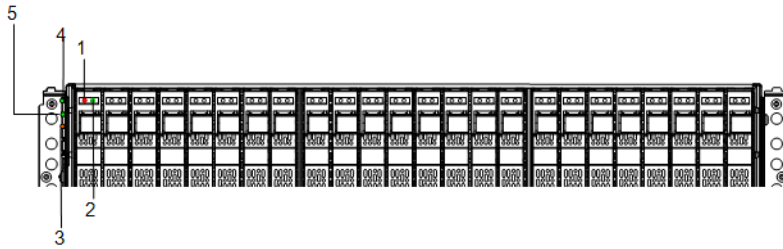

Figure 4-26: Modular 2U SAS expansion unit disk drive LEDs

Table 4-27: Modular 2U SAS expansion unit disk drive LEDs

Number	LED	Function
1	HDD ALM LED (red)	ON: A failure has occurred in the disk drive and it is inoperable.\
2	HDD ACT LED (green))	ON or FLASHING: the disk drive is operational.
3	LOCATE LED (orange)	ON: A failure has occurred in the unit, but the failure does not stop operation
4	POWER LED (green)	ON: Power is supplied to the unit.
5	READY LED (green)	ON: The unit is operable.

Modular 2U SAS expansion unit power unit

Description of RKAKS power unit.

Power supply status

As shown in Figure 4-27, each power supply has three LEDs on the panel near the power receptacle. These LEDs indicate the operational status of the power supply, and are described in Table 4-28 on page 4-35.



Figure 4-27: Modular 2U SAS expansion unit power supply LEDs

Table 4-28: Modular 2U SAS expansion unit power supply LEDs

No.	LED	Function
1	ALM LED (red)	ON: An abnormal or stop state.
2	RDY LED (green)	ON: Operating normally.
3	AC IN (green)	ON: AC input is normal.

Modular 2U SAS expansion unit ENC unit

The ENC unit is mounted in the expansion unit. It is the interface between the expansion unit in which it is mounted and the controller in a base unit or the ENC unit in another expansion unit. The ENC unit is shown in Figure 4-28.

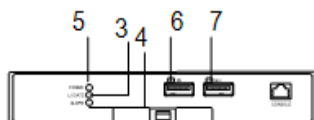

Figure 4-28: Modular 2U SAS expansion unit ENC Unit

No.	LED	Function
3	LOCATE LED (orange)	The following blinking is fast because ENC microprogram detects CUDG error: High-speed blinking Twice: ENC hard error Three times: Microprogram error in flash memory Not blinking: Boot section error of ENC microprogram, RAM error or ENC hard configuration error.
4	ALARM LED (red)	ON: A failure has occurred in the ENC unit and it is inoperable
5	POWER LED (green)	ON: Power is supplied to the unit
6	PATHO (in) side LED (green)	ON: The IN side is linked up
7	PATHO (out) side LED (green)	ON: The OUT side is linked up

Table 4-29: Modular 2U SAS expansion unit ENC Unit

High-density expansion unit

A high-density expansion storage unit (factory designation RKAKX) provides significant additional storage capabilities for the base units. It contains from 4 to 48 SATA disk drives, four redundant power supplies, and four ENC adapter units (cards). The ENC units manage the drives and are also used to connect the expansion unit to the base unit, expansion units, and other expansion units. See [Disk drive configurations](#) in this chapter and [RAID implementations on page 1-22](#) for detailed information about the number and type of disk drives that can be installed in an expansion unit.

There are no switches on a high-density expansion unit. Power is turned on and off with a control signal that is routed from the base unit via the ENC cables that are connected to the ENC unit in the high-density expansion unit.

Both the AMS 2100 and the AMS 2300 base units use the same high-density expansion unit. They each support only one high-density expansion unit.



NOTE: Disk drives are installed, removed, and replaced from the top of the high-density expansion unit. No tools are required, but the cover over the drives is locked and must be unlocked from the key on the front panel of the unit (see [Figure 4-30](#)).

High-density expansion unit front view

[Figure 4-29](#) shows the front of a high-density expansion unit with the decorative front bezel installed.

The front panel of the high-density expansion unit includes two sets of Power and Locate status LEDs that show the status of each section (A and B) in the unit and identify the unit in case of a failure. The installation location should provide an unobstructed view of these LEDs.



Figure 4-29: High-density Expansion Unit Front View

High-density expansion unit front panel

Figure 4-30 shows the front panel of a high-density expansion unit with the front bezel removed. The Locate and Power LEDs are visible with the front bezel removed or installed.

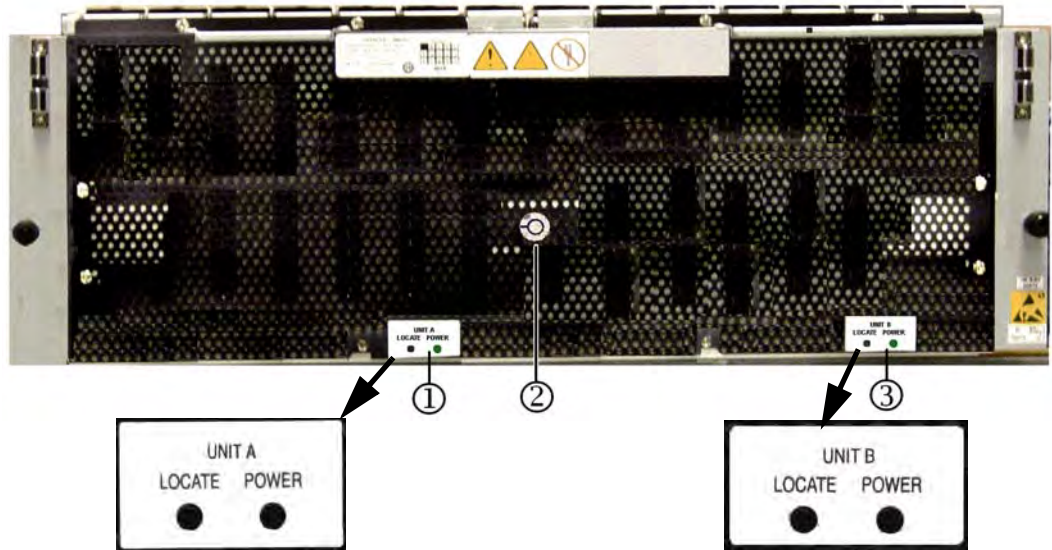

Figure 4-30: High-density Expansion Unit Front Panel

Table 4-30: High-density Expansion Unit Front Panel

Item	Description	Item	Description	Item	Description
①	Unit A Status LEDs	②	Drive Cover Lock. Uses same key as AMS 2100/2300/2500 front bezel.	③	Unit B Status LEDs

High-density expansion unit status LEDs

Table 4-31 describes the array status LEDs and their functions.

Table 4-31: High-density Expansion Unit Status LEDs

Item	Name/Color	Status	Description
①	LOCATE (orange)	OFF	Normal operation
		ON	A serious error has occurred in the unit. Please contact Hitachi Data Systems Technical Support. See the Getting Help section in the Preface of this manual.
②	POWER (green)	ON	Normal operation; the section is fully operational.
		Slow Blink	The firmware download is complete.
		Fast Blink	The firmware is downloading (do not turn off the array).

High-density expansion unit rear panel

The rear panel of a high-density expansion unit includes four power supplies, four ENC-IN ports, and four ENC-OUT ports. The ports provide the connections to daisy-chain high-density expansion units in the array. See [Chapter 5, Installation](#) for details. The rear panel also provides LEDs that show the status of the ENC units and the power supplies. [Figure 4-31](#) shows the hardware components on the rear panel of a high-density expansion unit. Expanded views and detailed descriptions of the high-density expansion unit power supplies and ENC adapters are located on the following pages.

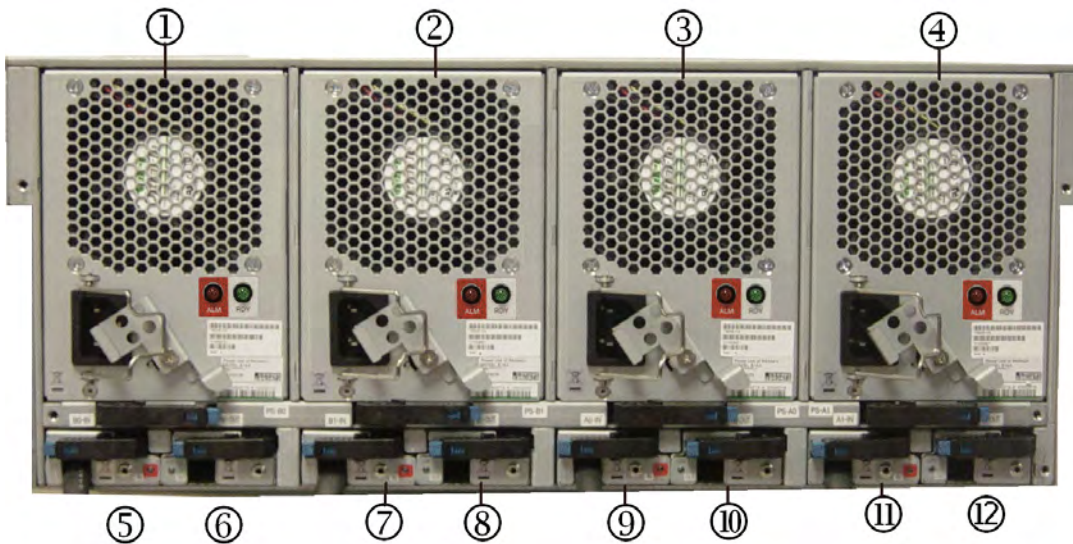

Figure 4-31: High-density Expansion Unit Rear Panel Components

Table 4-32: High-density Expansion Unit Rear Panel Components

Item	Description	Item	Description	Item	Description
①	Power Supply 0B	⑤	ENC Unit B0 IN	⑨	ENC Unit A0 IN
②	Power Supply 1B	⑥	ENC Unit B0 OUT	⑩	ENC Unit A0 OUT
③	Power Supply 0A	⑦	ENC Unit B1 IN	⑪	ENC Unit A1 IN
④	Power Supply 1A	⑧	ENC Unit B1 OUT	⑫	ENC Unit A1 OUT

High-density expansion unit power supply

As shown in [Figure 4-31](#), the high-density expansion unit has two fully redundant power supplies for each section in the unit (total of four power supplies). If one power supply in a section fails, the other one can supply sufficient power and cooling to the section until the failed power supply is replaced.

Power supply status

Each power supply has two LEDs on the panel near the power receptacle. These LEDs indicate the operational status of the power supply, as shown in [Figure 4-32](#).

	Item	Description
	①	<p>Alarm LED (red). This LED indicates that the power supply has failed. Although the other power supply can supply sufficient power and cooling for the array, Hitachi Data Systems recommends that you replace the failed power supply as soon as possible. Contact Hitachi Data Systems Technical Support for instructions.</p>
	②	<p>Ready LED (green).</p> <p>OFF when the power supply is not connected to power.</p> <p>Blinks when the corresponding power receptacle is connected to a working AC outlet, and is running the power on self test (POST).</p> <p>ON when the power supply is operational, even if the AMS 2100/2300 array is not turned on.</p>
	③	Power Receptacle (see next page)
	④	Lock Lever

Figure 4-32: High-density Expansion Unit Power Supply Components

Power receptacles

Each power supply contains a power receptacle that must be connected to a working AC power source using the supplied AC power cable.



NOTE: Hitachi Data Systems recommends that each power supply in the base unit be connected to a different AC source in the rack. If one source fails, the other source continues to supply power to the other power supply. This keeps the array running until power is restored to the failed source.

Safety lock

The high-density expansion unit power supply includes a safety lock that prevents the lock lever from being opened until the power cable is disconnected from the power supply. This prevents the power supply from being removed from the unit with the power applied.

As shown in [Figure 4-33](#), the power supply also includes a power cable retainer that can be used to ensure that the power cable is not accidentally disconnected from the power supply.



NOTE: Hitachi Data Systems recommends that you install the cable retainer to prevent the power cable from accidentally being disconnected from the power supply.

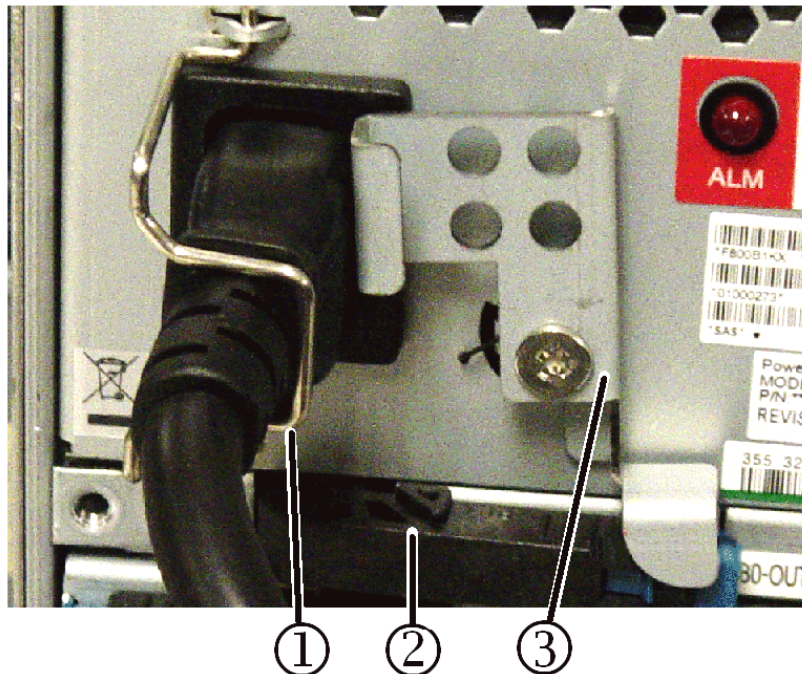

Figure 4-33: High-density Expansion Unit Power Supply Safety Components

Table 4-33: High-density Expansion Unit Power Supply Safety Components

Item	Description	Item	Description	Item	Description
①	Power Cable Retainer	②	Lock Lever	③	Safety Lock

High-density expansion unit ENC connectors

The ENC cards in the high-density expansion unit are mounted inside the unit and do not have direct access to the outside of the unit. Each ENC card is connected to two ENC connector extension units (IN and OUT) that connect the ENC cables to the ENC card. As shown in, [Figure 4-31 on page 4-38](#), the connector extensions are located below the power supplies.

The ENC IN connector includes an ALM (alarm) LED that turns on when the ENC card to which it is connected fails. The LOC (locate) LED for the ENC unit is located on the OUT connector.

[Figure 4-34](#) shows the connectors removed from the high-density expansion unit and open to show how the ENC cable is connected inside.

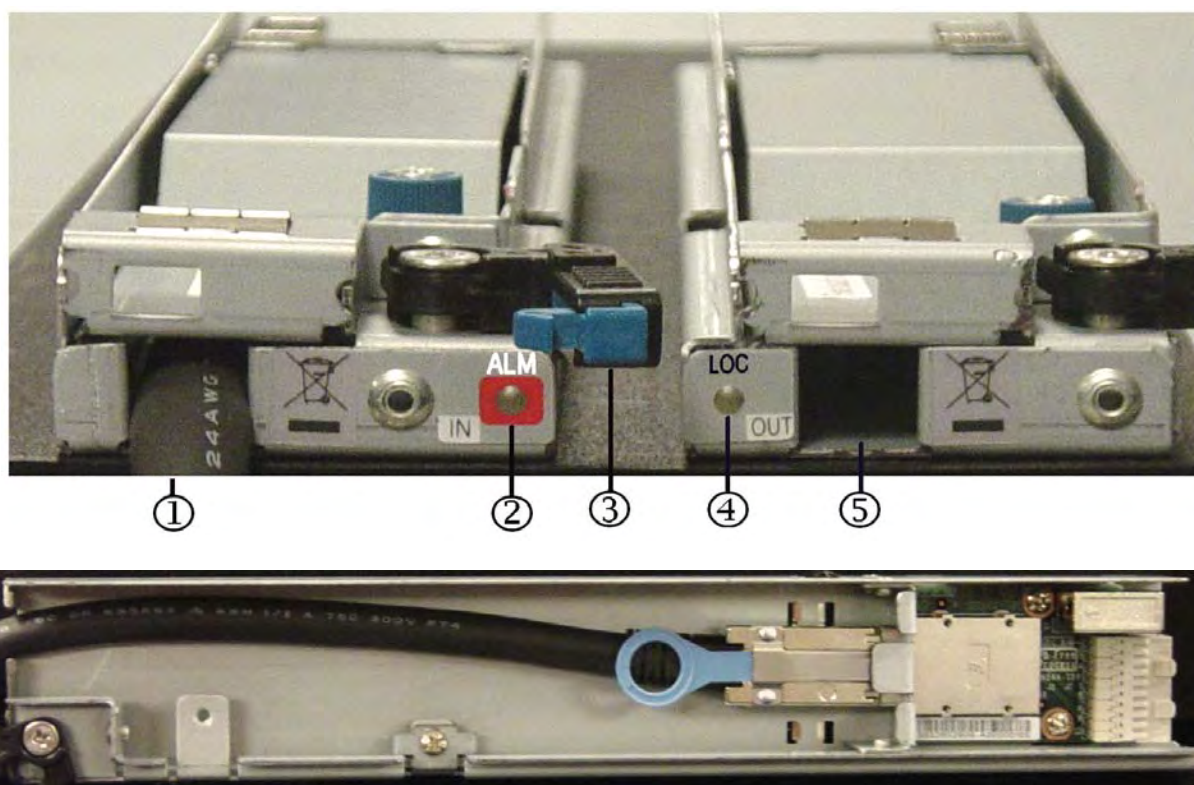

Figure 4-34: ENC Connectors

Table 4-34: ENC Connectors

Item	Description	Item	Description
①	ENC Port (IN). Connects to the OUT port on either the base unit controller the IN port on the ENC unit in an expansion unit or high-density expansion unit.	②	ALM (alarm) LED (red) This LED indicates that the ENC unit has failed.
③	Lock Lever	④	LOC (locate) LED (orange) See Table 4-25 on page 4-32 .
⑤	ENC Port (OUT). Connects to IN on either the controller on a base unit or the IN port on the ENC unit in an expansion unit or high-density expansion unit.		

High-density expansion unit top view

Figure 4-35 shows the top view of high-density expansion unit with the drive cover removed. The disk drives and ENC cards can be seen, along with the drive fillers where disk drives are not installed. These are required to prevent loss of cooling air to the drives.



Figure 4-35: High-density Expansion Unit Top View

Table 4-35: High-density Expansion Unit Top View

Item	Description	Item	Description
①	Power Supply Area	③	Disk Drive Filler (must be in all slots that do not have disk drives installed.)
②	ENC Unit (four required)	④	Disk Drive. See Disk Drive Configurations following this table.

Disk drive configurations

As shown in [Figure 4-35](#), a high-density expansion unit has 48 drive slots in drive section of the unit. Each slot can accommodate one SATA drive or one drive filler. A drive filler is a solid but lightweight box that fills the slot to maintain airflow within the high-density expansion unit if 48 drives are not installed.

The following requirements for the high-density expansion unit apply whether it is connected to an AMS 2100 or to an AMS 2300.

- All disk drives in this unit must be SATA drives.
- The Hitachi Data Systems minimum supported number of drives that must be installed in the high-density expansion unit is two in Unit A (slots 0-1) and two in Unit B (slots 0-1).
- After the minimum configuration is met, you can add up to two SATA drives in each unit (which makes a RAID1 configuration) at a time, or other combinations of drives as required to meet the RAID configurations specified in Chapter 1.

Disk drive status LEDs

Each disk drive in the high-density expansion unit has an ALM (alarm) LED on the top edge of the drive that shows the status of the disk drive. This LED, shown in [Figure 4-36](#), indicates the drive has failed.

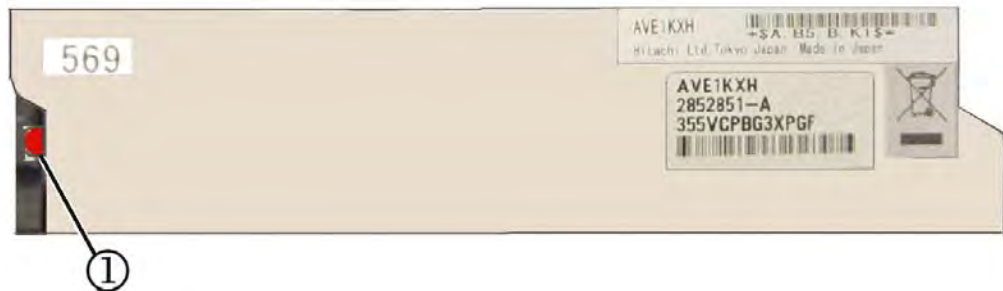

Figure 4-36: Disk Drive Alarm LED

Table 4-36: Disk Drive Alarm LED

Item	Description
①	Alarm LED (red) Lights when the drive has a serious error.

With the drive cover removed, the drives and any lighted alarm LEDs are visible, as shown in [Figure 4-37](#).



Figure 4-37: Alarm LED Locations

High-density expansion unit ENC card

As shown in [Figure 4-35 on page 4-42](#), four ENC units (cards) are mounted in the disk drive area of the high-density expansion unit. The ENC cards are the interfaces between the high-density expansion unit in which they are mounted and the controller in a base unit or the ENC unit in a standard expansion unit or another high-density expansion unit. Each ENC card has a LOC (locate) LED and an ALM (alarm) LED. They are described in the table below the following figure. The ENC card is shown in the following figure. The upper photograph shows the top edge view of the ENC card, with an expanded view of the status LEDs.

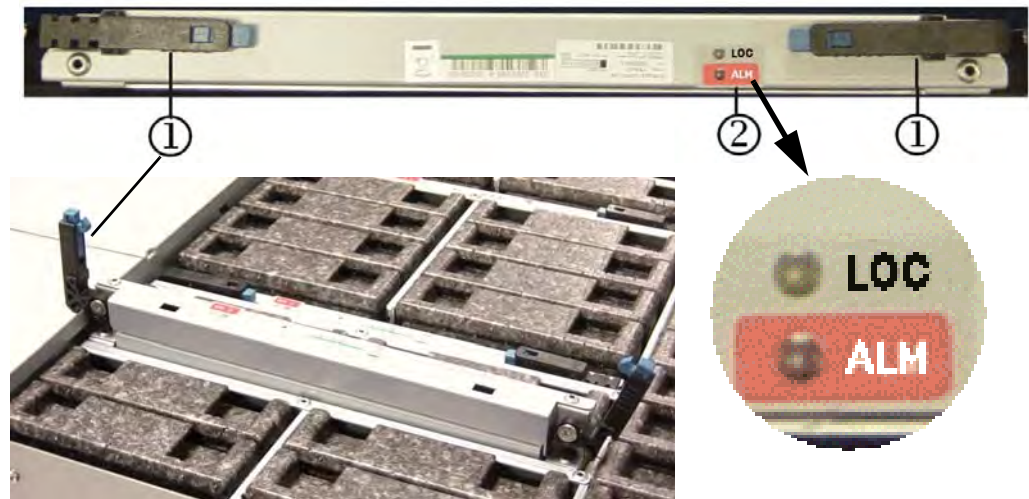

Figure 4-38: High-density Expansion Unit ENC Unit

Table 4-37: High-density Expansion Unit ENC Unit

Item	Description			
①	Lock Lever	Secures the ENC unit in the chassis.		
②	Status LEDs	Alarm (red)	This LED indicates that the ENC unit has failed.	
		LOCATE (orange)	OFF	Normal operation
			Blinking	Voltage on the control unit is abnormal. (Reset of the control unit is not canceled)
			6 (slow)	SRAM error.
			1 (fast) ¹	ENC hard error.
2 (fast)	Firmware error in flash memory.			
3 (fast)	CUDG error in ENC.			
4 (fast)	Voltage on the control unit is abnormal. (Reset of the control unit is not canceled)			
6 (slow)	Boot section error in the ENC firmware, a RAM error, or ENC hard configuration error.			
ON				

1. When blinking fast, the LED is on for 400ms and off for 200 ms for each fast blink. After the number of fast blinks has completed, the LED is off for one second.

Installation

This chapter describes the procedures to install a Hitachi AMS 2100/2300 Storage System. The installation procedures include instructions to connect data, control, and power cables to the units, as well as references to information to install additional components. It includes the following key topics:

- ❑ [Chapter overview and task list](#)
- ❑ [Safety considerations](#)
- ❑ [Preinstallation requirements](#)
- ❑ [Installing an AMS 2100/2300](#)
- ❑ [Installing Storage Navigator Modular 2](#)

Chapter overview and task list

The following table lists the main installation tasks. Click the page number to display the detailed instructions for each task.

Table 5-1: Installation Roadmap

Step	Description	See Page
1.	Review all safety considerations before you start the installation process.	5-2
2.	Prepare the site where you intend to install the array.	5-18
3.	Unpack the array. Ensure that all items on the packing list are accounted for and not damaged.	5-24
4.	Obtain the required user-supplied items to perform the installation.	5-18
5.	Install the array in a rack.	5-30
6.	Configure and manage your storage.	7-9
7.	Consult the Hitachi AMS 2000 Family iSCSI Host Installation Guide or Hitachi AMS 2000 Family Fibre Channel Host Installation Guide.	--

Safety considerations

Personal safety

Observe the following guidelines to ensure your safety. Failure to follow these guidelines could result in bodily injury and/or damage to the array or its components.



CAUTION! A fully populated AMS 2300 base unit weighs approximately 125 pounds (57 kg). Do not attempt to lift or move the unit alone. Use at least three people to lift and/or move the unit. Before lifting the unit, always turn off the power to the unit and unplug all data and power cables. An expansion unit weighs 88 lbs (40Kg) Use at least two people to unpack and install an expansion unit.

Install the base unit at the bottom of the rack. If the array is mounted at the top of the rack, the rack may become unstable and fall.





CAUTION! Be sure to use at least three people to install the unit in a rack. Work carefully to prevent the unit from slipping or falling.

Be sure to install the base unit at the bottom of the rack and any expansion units above it to prevent the rack from falling. Lift the unit up to the height suitable for mounting. Adjust the position of the array so it is seated in the horizontal center of the rack. Slide the array onto the rails in the rack. When sliding the array onto the rails, move it gently all the way onto the rails.



WARNING!

- Do not wear loose clothing that could get caught in the chassis or mounting hardware.
 - Wear safety glasses when working under conditions that are hazardous to your eyes.
 - Do not perform any action that creates a potential hazard to people or makes the equipment or rack unsafe.
 - Do not work on the equipment or disconnect cables during a thunderstorm, when wearing a wool sweater or other heavy wool clothing, or when power is applied.
 - Disconnect all power before installation.
 - Avoid hazards such as moist floor.
 - Do not use ungrounded power-extension cables.
-

Electrical safety guidelines



ELECTRIC SHOCK HAZARD!

- The power supplies and backup batteries can contain electricity even when the power is turned off and the units are disconnected from the electrical supply.
 - Do not disassemble the power supplies or backup batteries.
 - Do not touch the electrical connectors on the rear of the power supplies or backup batteries.
 - When replacing power supplies or backup batteries, make certain that the replacement units are the same model number as the units being replaced.
 - Do not install or remove any ENC or power cables with the power on. The ENC cables carry a power control signal to the expansion units. (LAN and Fibre Channel cables can be installed or removed with the power on.)
 - When working with high voltage, do not work alone. Work with another person who can immediately turn off the power in an emergency.
-

Handling of cables on the floor

- Protect cables that cannot be routed within a rack and are laid on the floor including across a doorway. Use a cable duct to prevent wear on the cable, tripping over, and walking on the cables, and thus laid on the floor or cables that cross a passage with cable ducts, etc.
- Do not route rack-to-rack cables in the air. Route them down the rack and under the floor if possible. Otherwise route them across the floor and use a cable duct to protect them.

Handling of under-floor cables

Use cables of sufficient length such that the cables can be laid somewhat loosely on the floor under the computer room floor, and are not hanging or stretched between the racks or arrays. Tight cables can be damaged or broken if stretched beyond their specified limits, as could happen in an earthquake.

Equipment safety

The following safety instructions are designed to help protect the array from various types of physical and electrical damage.

- Moisture. Do not store or install the unit in a place where moisture exists or is likely to condense on the unit.
- Heat. Do not install the unit in a rack which has less than the specified cooling. The AMS 2100/2300 has heat sensors which will cause the unit to shut down if the internal temperature exceeds the specifications. See the *Hitachi AMS 2000 Family Storage System Reference Guide* for details.
- Electromagnetic interference (EMI). When the array is operating under normal conditions, close the rack doors if installed. This helps to protect the array from EMI.





Static-sensitive. Ground yourself before touching.

To avoid damage to the array or array components due to electrostatic discharge (ESD), wear an anti-static wrist strap when handling, installing, or removing any components from the array. Connect the clip to an unpainted part of the array chassis frame to safely channel any static electricity generated by your body to ground. If no wrist strap is available, ground yourself by touching an unpainted part of the array chassis frame.

Warning labels

In this equipment, warning labels are posted on areas requiring special care. Warnings written on them are primarily for service personnel. The following are symbols contained in warning labels.

Table 5-2: Warning Labels

Symbol	Description
	Do not disassemble the equipment.
	Handle the heavy equipment carefully.

Warning and safety labels (base unit)

Figure 5-1 shows the location and content of the warning and safety labels on the base unit.

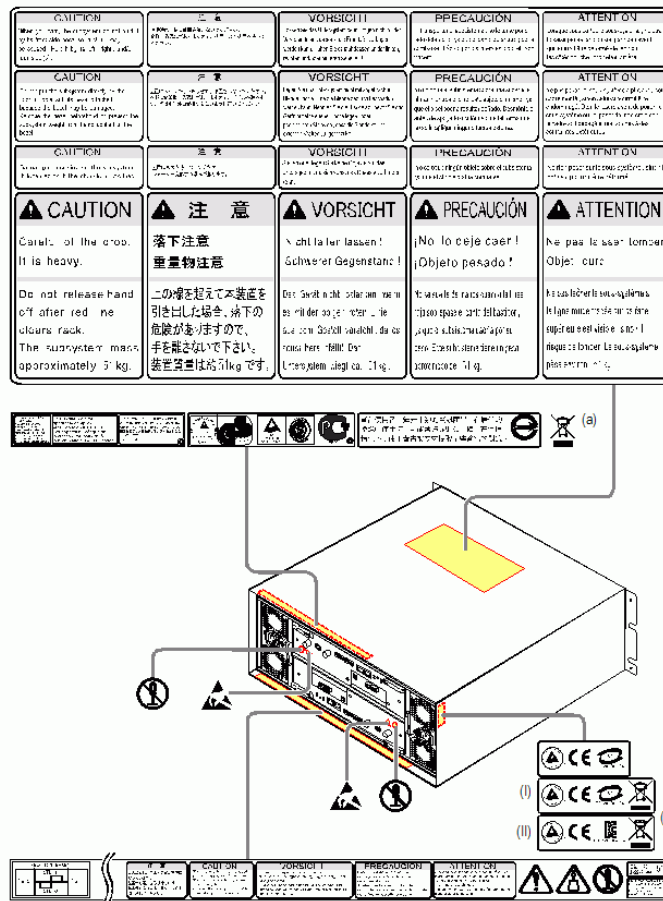



Figure 5-1: Warning and Safety Labels (Base Unit)

The  label is affixed at location (a) or (b). Either (I) or (II) is affixed.

Warning and safety labels (expansion unit)

Figure 5-2 shows the location and content of the warning and safety labels on the expansion unit.

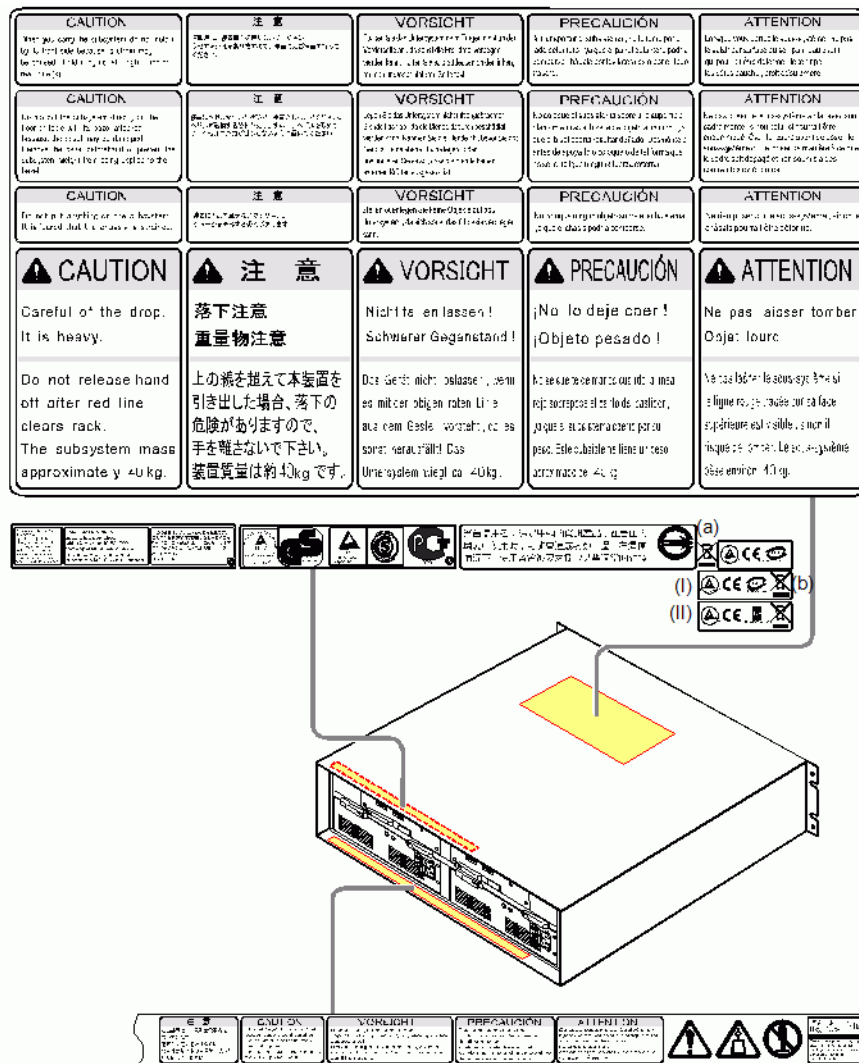

Figure 5-2: Warning and Safety Labels (Expansion Unit)

The  label is affixed at location (a) or (b).
Either (I) or (II) is affixed

Warning and safety labels (modular 2U SAS expansion unit)

Figure shows the location and content of the warning and safety labels on the expansion unit.

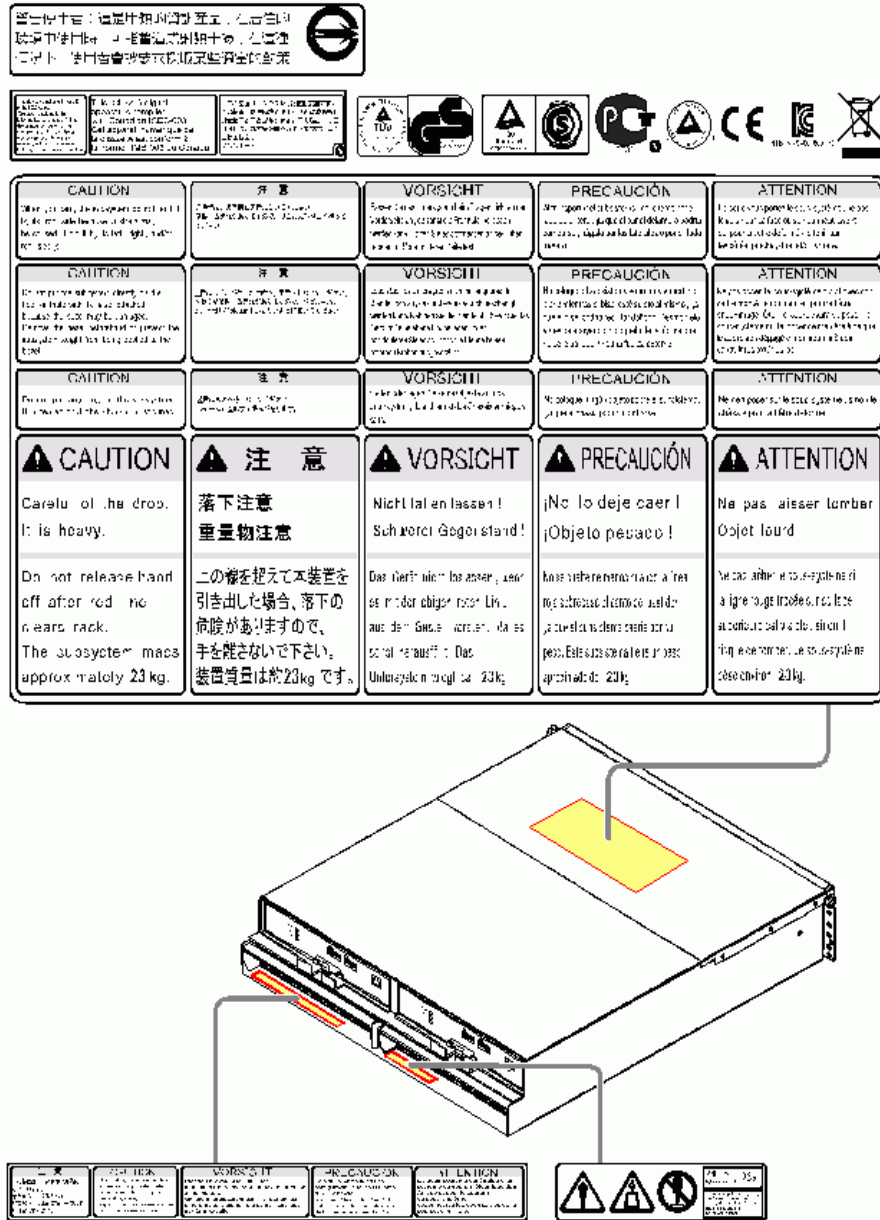

Figure 5-3: Warning and Safety Labels (modular 2U SAS expansion unit).

Warning and safety labels (high-density expansion unit)

Figure 5-4 shows the location and content of the warning and safety labels on the high-density expansion unit.

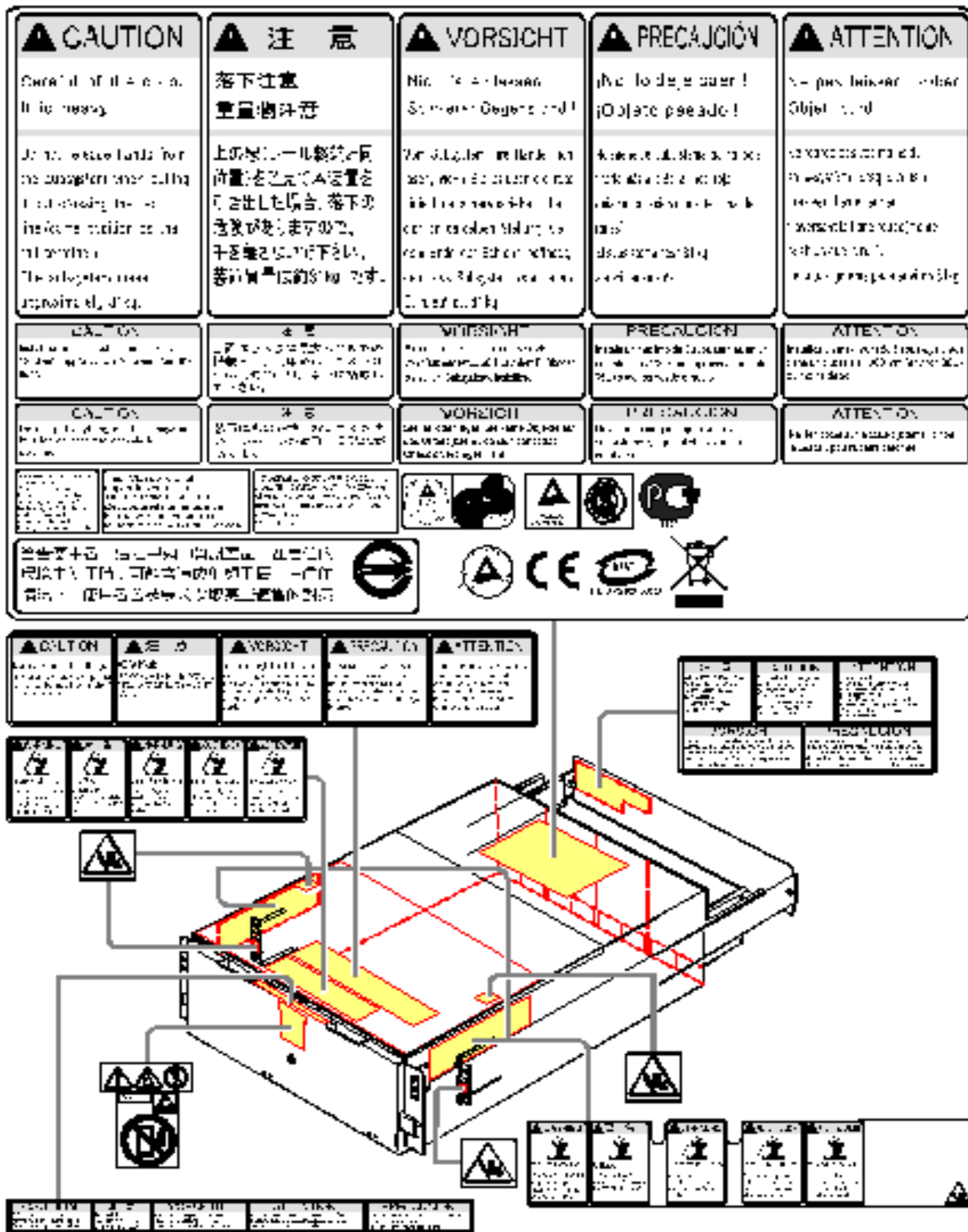



Figure 5-4: Warning and Safety Labels (High-density Expansion Unit)

The  label is affixed at location (a) or (b).

Disk drives

Figure 5-5 shows the location of the label on the Base Expansion Unit disk drive.

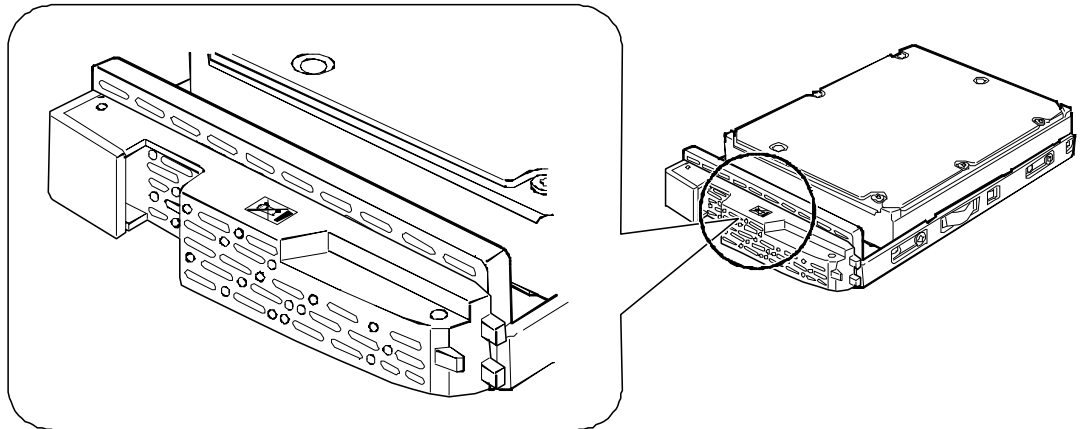

Figure 5-5: Base Expansion Unit Disk Drive

Figure 5-6 shows the location of the label on the High-density Expansion Unit disk drive.

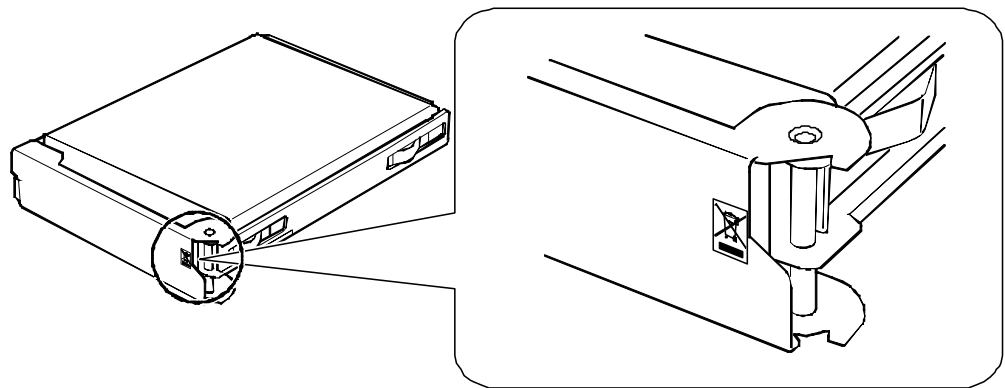
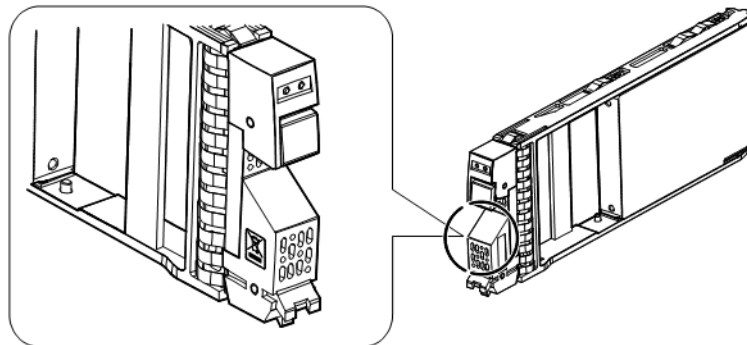

Figure 5-6: High-density Expansion Unit Disk Drive

The figure below shows the location of the label on the modular 2U SAS Expansion Unit disk drive.



Battery unit

Figure 5-7 shows the location of the label on the Battery Unit.

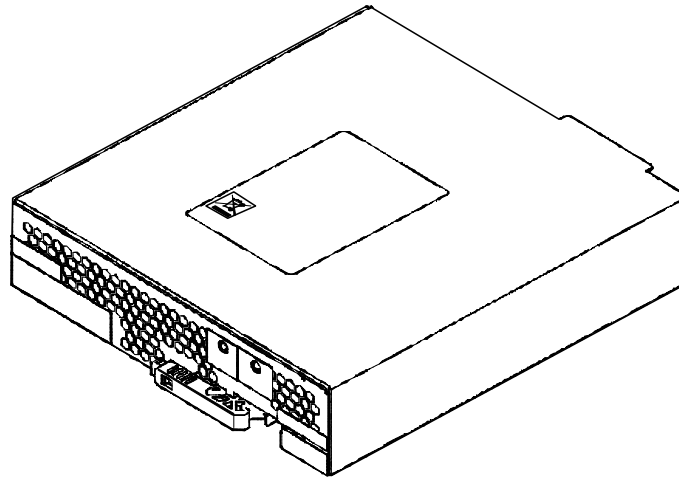

Figure 5-7: Battery Unit

Power supply

Figure 5-8 shows the location of the label on the Power Supply for the Base Unit.

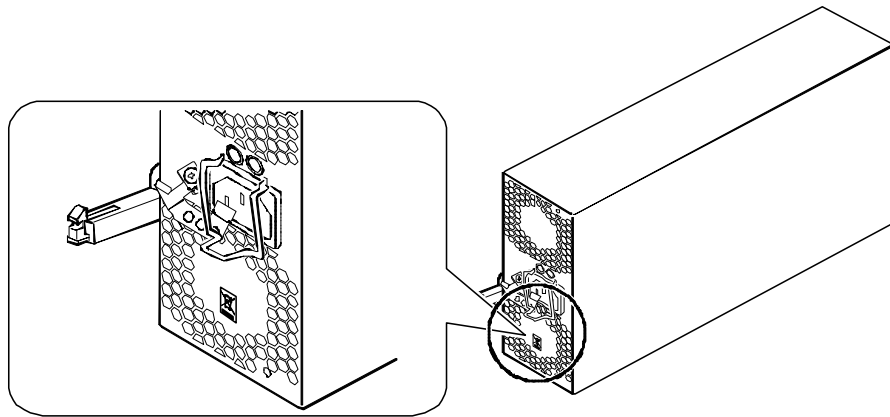

Figure 5-8: Power Supply Label Location for the Base Unit

Figure 5-9 shows the location of the label on the Power Supply for the Expansion Unit.

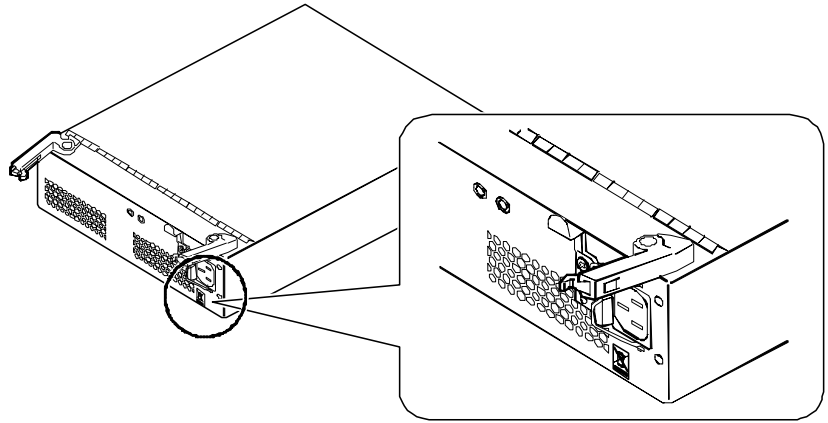

Figure 5-9: Power Supply Label Location for the Expansion Unit

Figure 5-10 shows the location of the label on the Power Supply for the modular 2U SAS the Expansion Unit

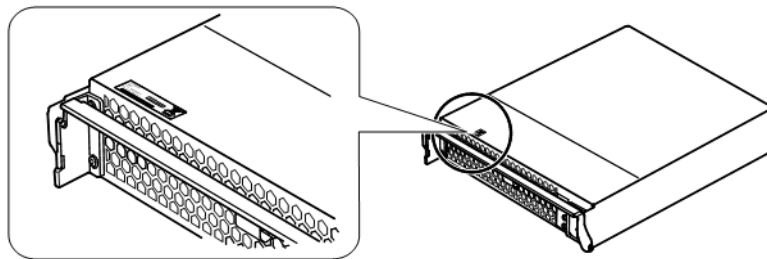

Figure 5-10: Power Supply Label Location for the Modular 2U SAS Expansion Unit

Figure 5-11 shows the location of the label on the Power Supply for the High-density Expansion Unit.

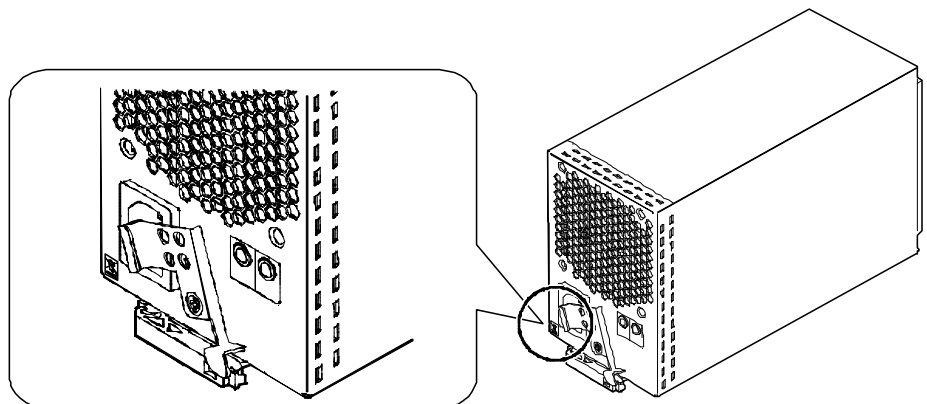

Figure 5-11: Power Supply Label Location for the High-density Expansion Unit

Control unit

Figure 5-12 shows the label locations on the AMS 2100 and 2300 Control Unit.

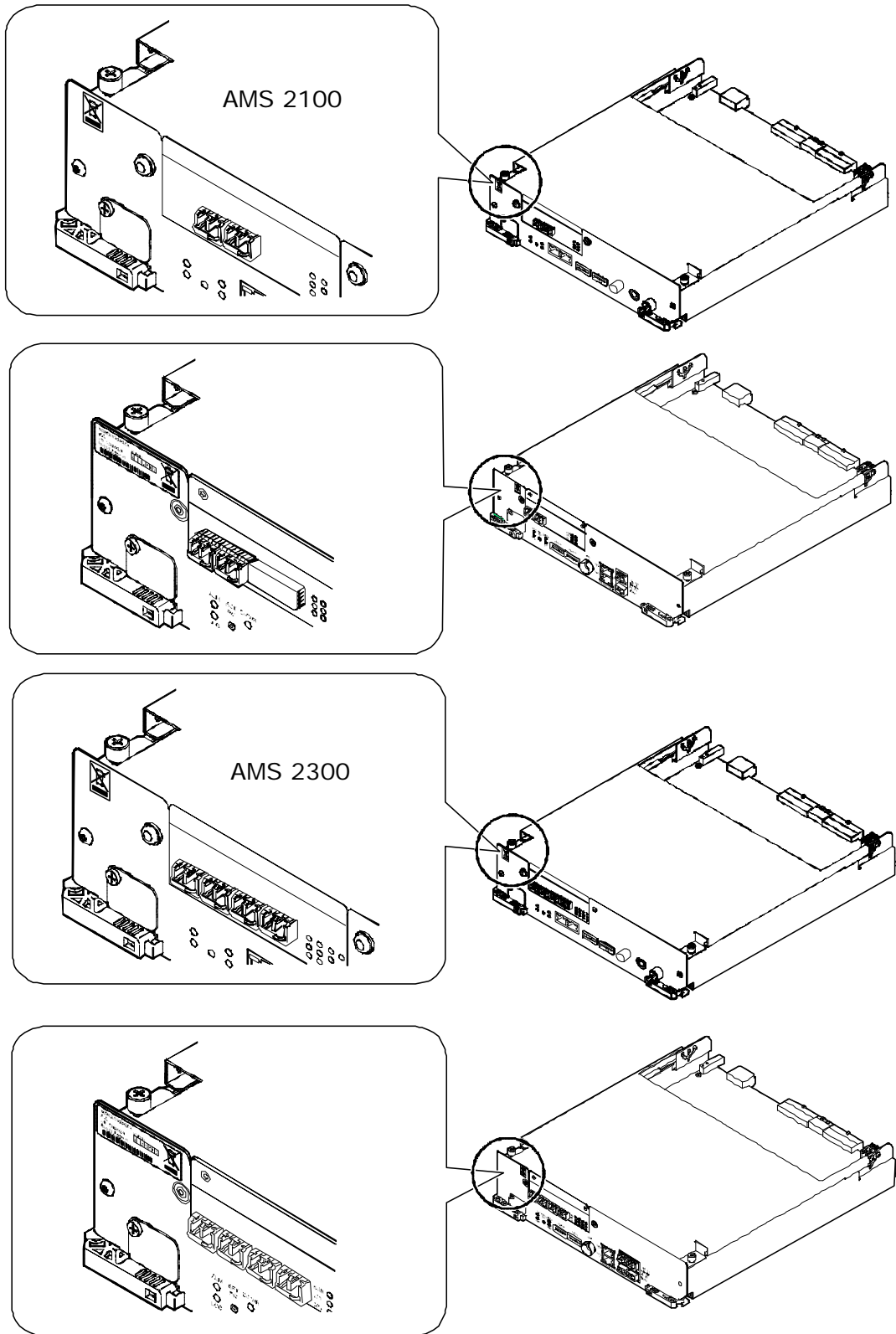

Figure 5-12: Control Unit Label Location

Cache memory

Figure 5-13 shows the location (a) or (b) of the labels on the Cache Memory module.

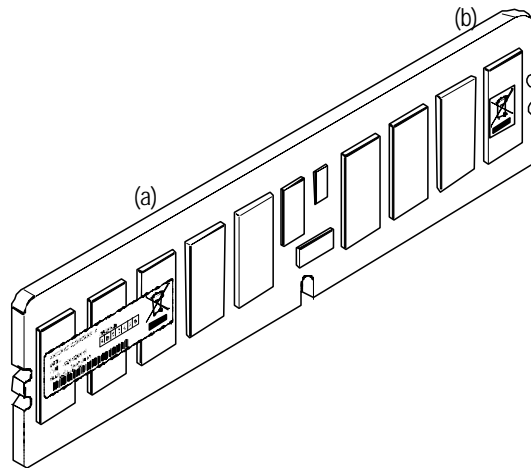

Figure 5-13: Cache Memory Label Location

Interface board

Figure 5-14 shows the location (a) or (b) of the labels on the FC Interface Board.

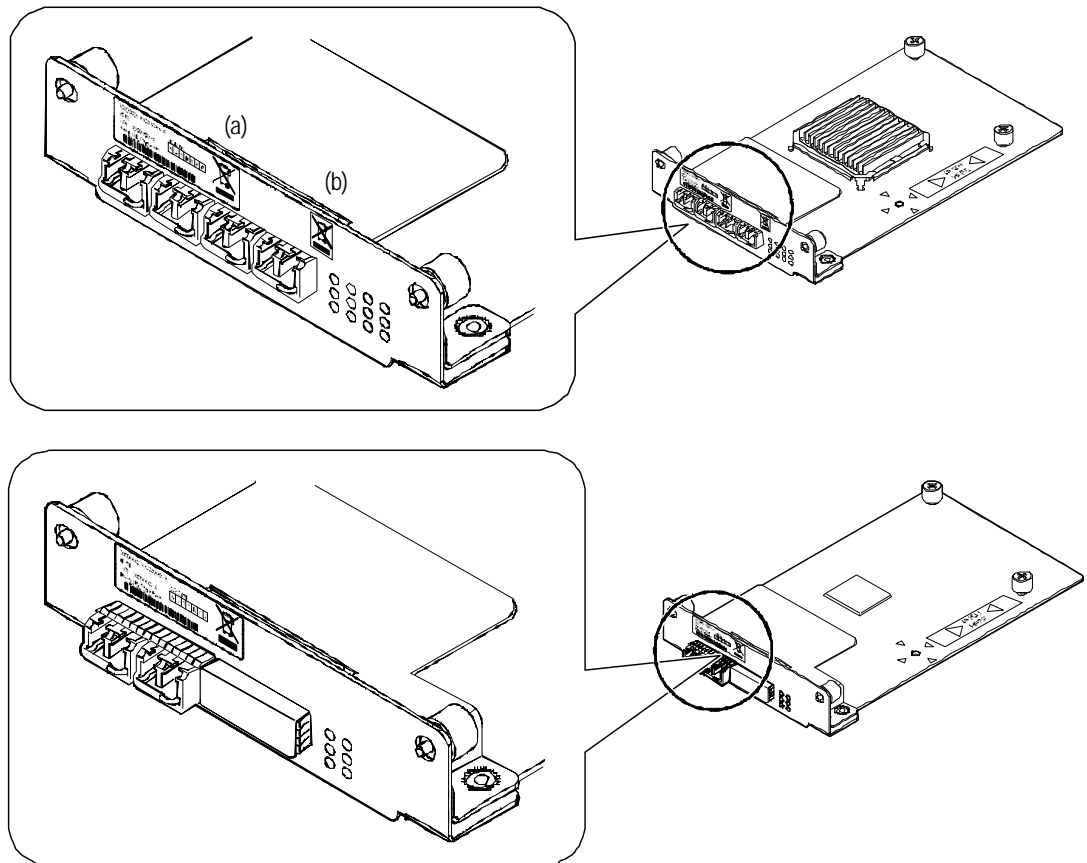

Figure 5-14: Fibre Channel Interface Board Label Location

Figure 5-15 shows the location of the label on the iSCSI Interface Board.

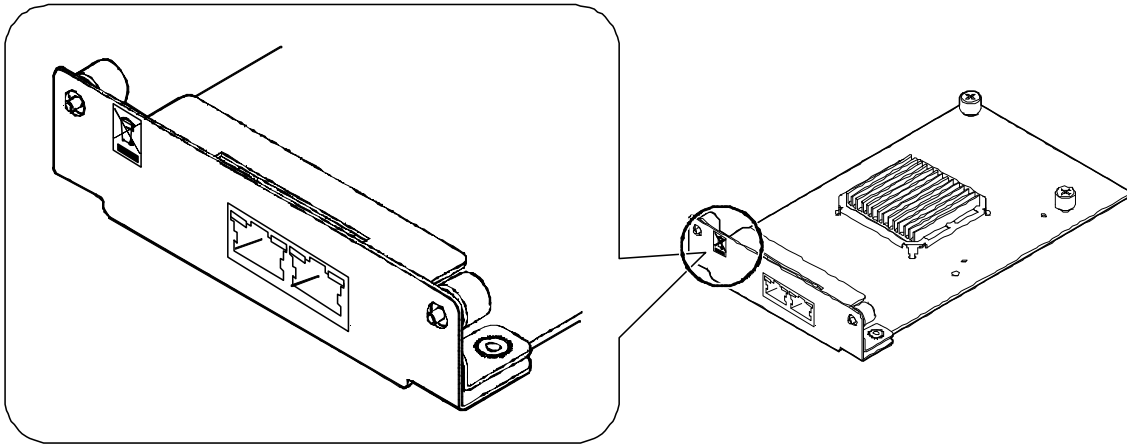

Figure 5-15: iSCSI Interface Board Label Location

Figure 5-16 shows the location of the label on the 10 Gbps iSCSI Interface Board.

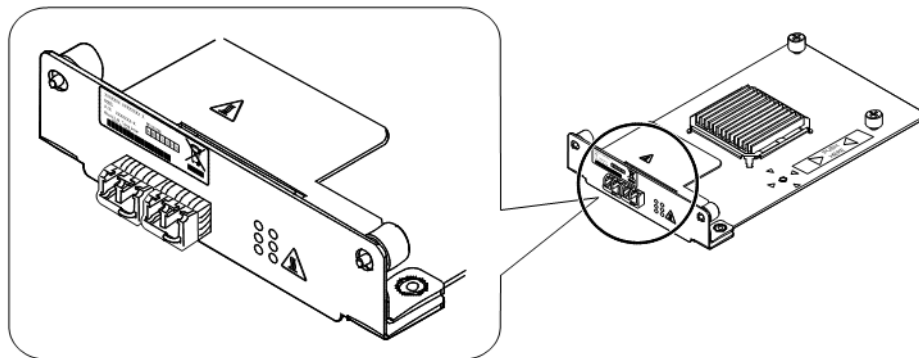

Figure 5-16: 10 Gbps iSCSI Interface Board Label Location

Host connector

Figure 5-17 shows the location of the label on the Host Connector.

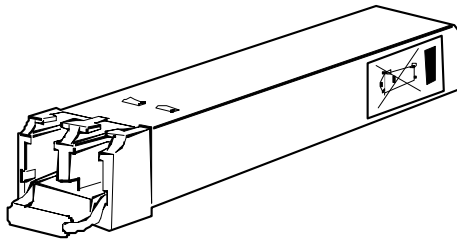

Figure 5-17: Host Connector Label Location

ENC unit

Figure 5-18 shows the location of the label on the ENC Unit of the Expansion Unit.

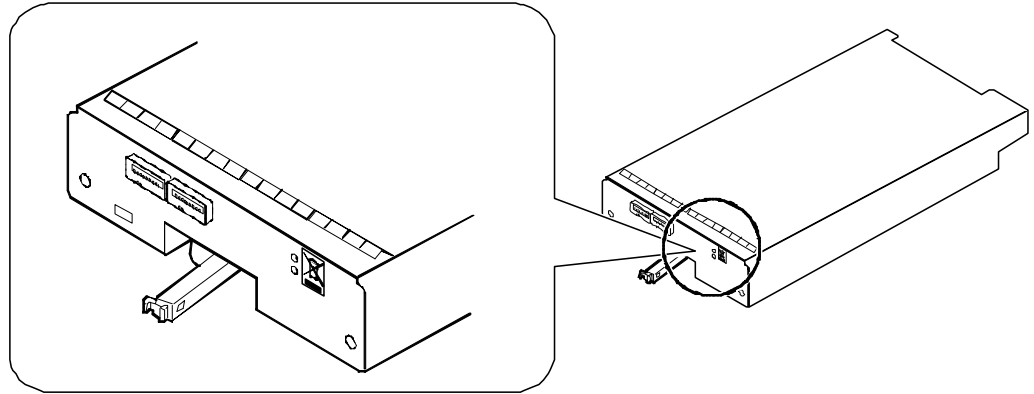

Figure 5-18: ENC Unit Label Location for the Expansion Unit

Figure 5-19 shows the location of the label on the ENC Unit of the Modular 2U SAS expansion unit

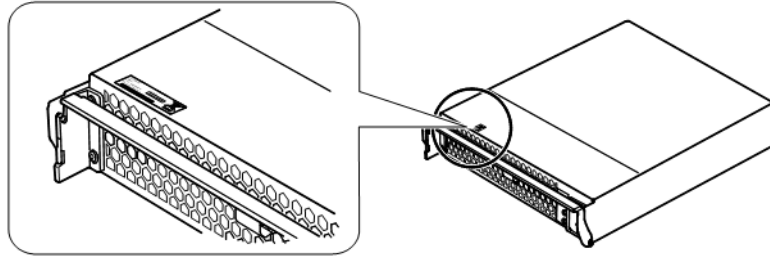

Figure 5-19: ENC Unit Label Location for the Modular 2U SAS Expansion Unit

Figure 5-20 shows the location of the labels (a) or (b) on the ENC Unit of the High-density Expansion Unit.

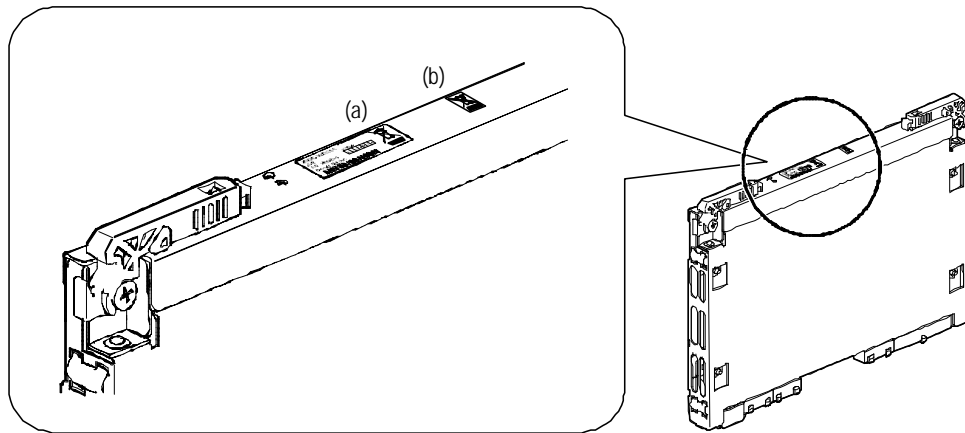

Figure 5-20: ENC Unit Label Location for the High-density Expansion Unit

ENC cable

Figure 5-21 shows the location of the label on the ENC Cable.

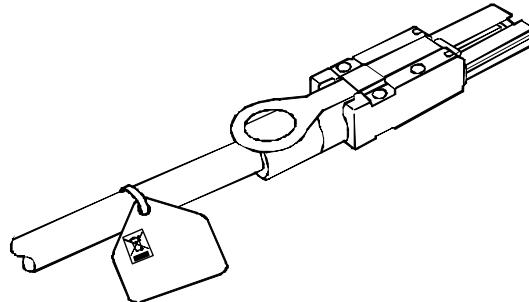

Figure 5-21: ENC Cable Label Location

Cable holder

Figure 5-22 shows the locations of the labels (a) or (b) on the Cable Holders.

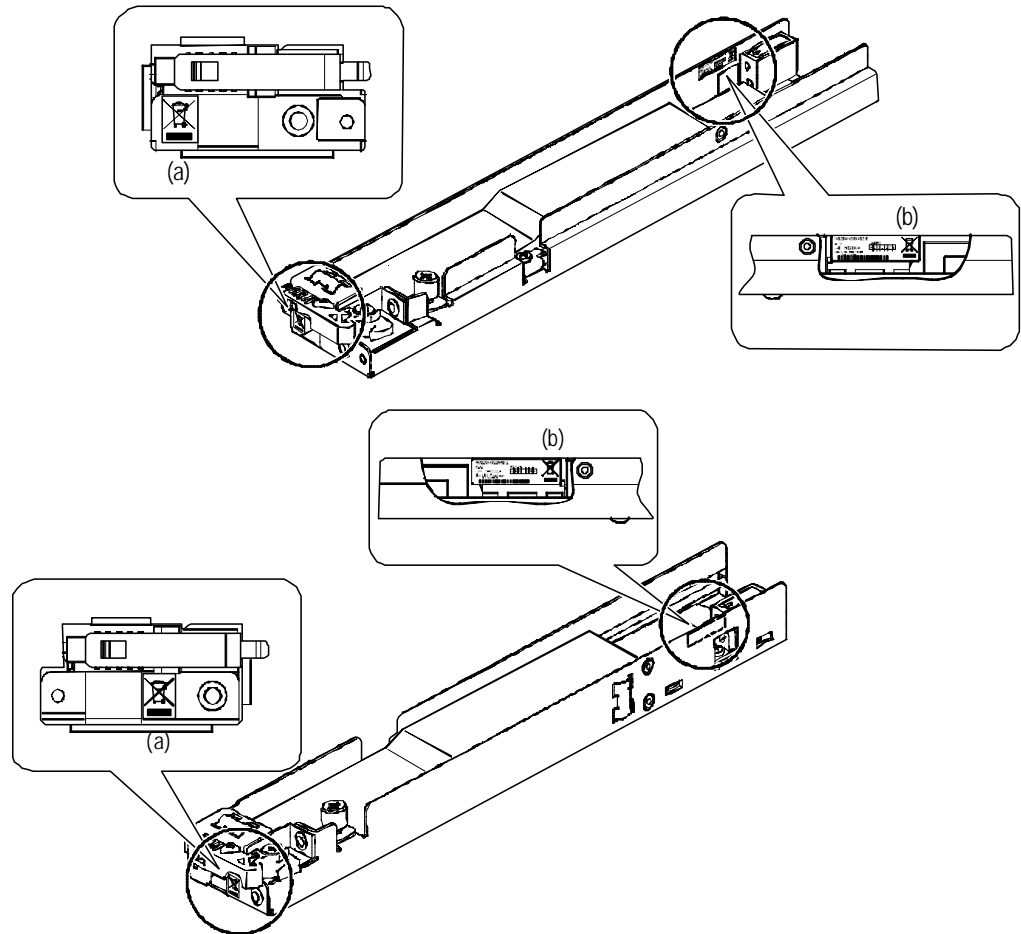

Figure 5-22: Cable Holder Label Locations

Preinstallation requirements

Ensure that the requirements in this section are completed before installing an array.

Site considerations

Ensure that the server room or other facility where the AMS 2100/2300 is installed complies with the electrical specifications and environmental specifications listed in the *Hitachi AMS 2000 Family Storage System Reference Guide* and also in the *Hitachi AMS 2000 Family Site Preparation Guide*.

User-provided items

Before the Hitachi AMS 2100/2300 array arrives for installation, obtain the following items to ensure proper installation and configuration.

- Physical space necessary for proper array function and maintenance activity
- Electrical input power
- Connectors and receptacles
- Air conditioning
- Floor ventilation areas (recommended but not required)
- Cable access holes in the floor

Installation site

To maintain the Hitachi AMS 2100/2300 performance, the Hitachi AMS 2100/2300 must be installed in a proper environment. For the environmental specification, refer to “Environmental Specifications” in the *Hitachi AMS 2000 Family Storage System Reference Guide*.

Do not install an AMS 2100/2300 in any of the following places:

- Where the array would be exposed to direct sunlight.
- Where the array would be exposed to variations in temperature and humidity
- Where the array would be near an apparatus that generates electric noise.
- Where the array would be near an apparatus that generates a strong magnetic field.
- Where the array would be exposed to a great deal of dust.
- Where the array would be exposed to frequent vibrations.
- Where the rack would be standing on inclined floor.



CAUTION! Do not store or install the equipment in a high temperature environment of 40 degrees centigrade or more, because battery life will be shortened.



CAUTION! Ensure that the rack in which the units are mounted is electrically configured with two AC circuits and that the power supplies for each base and expansion unit are connected to separate circuits. This prevents unit failure in case one of the power circuits fails.

Floor load rating

Before installing the base and expansion units in a rack, check the load-bearing specifications of the floor where you are placing the rack(s). To assure adequate load-bearing capacity, plan for the maximum configuration. See [Table 5-3](#). Be sure to include the weight of the rack when calculating the floor loading. Please refer to the AMS 2000 Family Site Preparation Guide, MK-98DF8149EN for information about the array and rack weights.

Installation area and service clearance

Please see the information and specifications in the *Hitachi AMS 2100/2300 Site Preparation Guide* before installing an AMS 2100/2300 storage system.

- Installation area means a large enough area to assure the intake and exhaust air.
- Service clearance means an area required to maintain the Hitachi AMS 2100/2300. Be sure to install the equipment in a place to avoid problems such as the inability to open the rack door completely or inadequate ventilation.

Notes about installation

- The array is provided with ventilating holes on external covers in order to prevent overheating. Therefore, be sure to leave at least 2 inches (5 cm) of space at the front and rear of the array so the ventilation holes are not blocked. Otherwise the array may overheat and fail.
- The direction of airflow is front/input to rear/output on the RK base controller tray and all RKAK/RKAKX drive trays.
- Hitachi Full-Height Solutions racks have a front door. AMS 2000 Family racks have no door in the front, but have a ventilated door in the back that allows the system to draw air through the front and exhaust air through the back. Do not block the front of mounted components or the rear-ventilated door.
- Use specified optional parts, cables, and connectors. Incorrect parts can cause a fire, personal injury, array failure, and/or reduced performance.
- If you detect an abnormal odor such as a something burning, unusual heat, or see smoke, turn off the power to the array from the distribution panel immediately and contact your service personnel.
- Do not put anything heavy on top of an array. Otherwise, the array may fall and cause personal injury.
- Do not put containers that contain any type of liquids or metal articles on top of the array. If they spill and accidentally get into the array, they can cause a fire, an electric shock, or an array failure.

Installation configurations

The AMS 2100/2300 is mounted in an AMS 2000 19-inch rack with extra depth.

In one rack:

- One RKS/RKES connects up to seven RKAKs (Disk Drive: Maximum of 120 units) at a maximum of 330.7 T bytes RAID5 (14D+1P) (using the 3,000 G disk drive).
- One RKS/RKES connects up to six RKAKSs (Disk Drive: Maximum of 159 units) at a maximum of 85.1 T bytes RAID5 (14D+1P) 10 + (8D+1P) (using the 600 G disk drive).
- One RKS/RKES connects three RKAKXs, (Disk Drive Maximum of 159 units,) at a maximum of 437 T bytes RAID5 (14D+1P) 10 + (8D+1P) (using the 3,000 G disk drive).

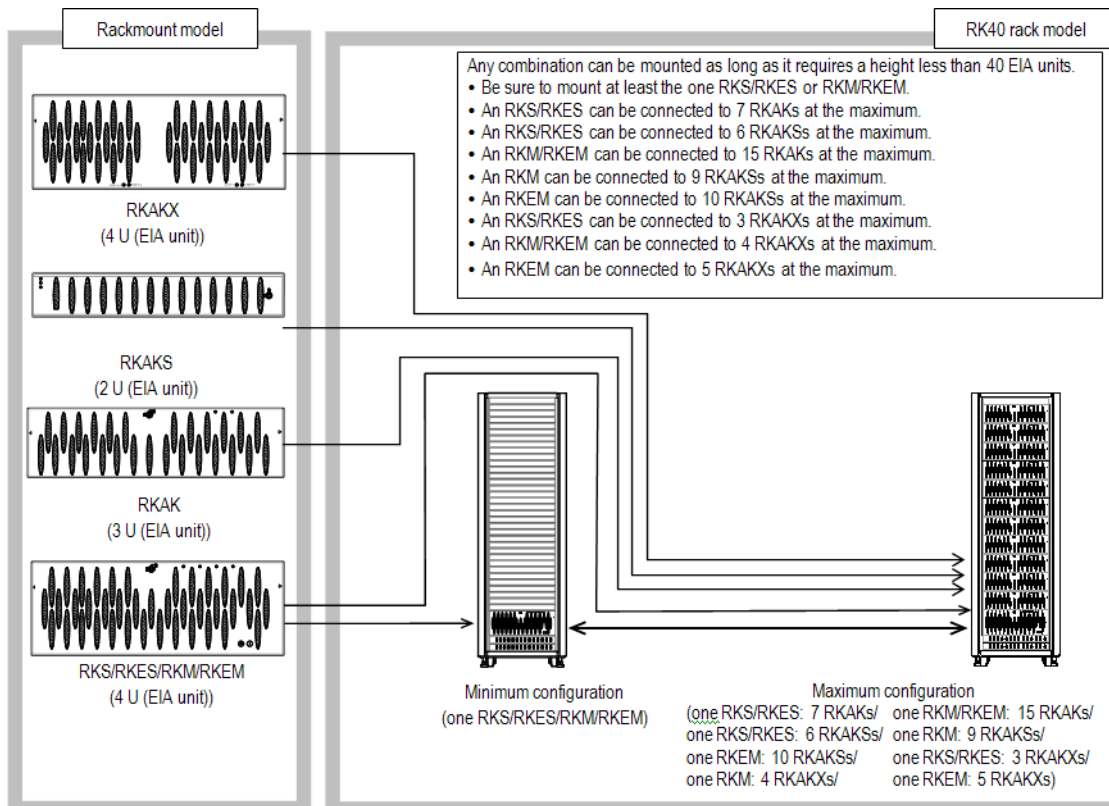

- One RKM connects up to 15 RKAKs (Disk Drive: Maximum of 240 units) at a maximum of 661.5 T bytes RAID5 (14D+1P) (using the 3,000 G disk drive).
- One RKM connects one RKM or up to one RKAK or up to four RKAKXs (Disk Drive: Maximum of 222 units) at a maximum of 611.3 T bytes RAID5 (14D+1P) 14 + (11D+1P) (using the 3,000 G disk drive).

However, when mounting subsystems mixing RKAKs and RKAKSs or RKAKs/RKAKSs and RKAKXs, a maximum of Disk Drives can not be mounted. For more details, refer to [Scalability \(page 1-15\)](#).

- One RKM connects up to nine RKAKSs (Disk Drive: Maximum of 231 units) at a maximum of 124.2 T bytes RAID5 (14D+1P) 15 + (5D+1P) (using the 600 G disk drive).
- One RKEM connects up to five RKAKXs (Disk Drive: Maximum of 255 units) can be made at a maximum of 702.8 T bytes RAID5 (14D+1P) (using the 3,000 G disk drive).
- One RKEM connects up to ten RKAKSs (Disk Drive: Maximum of 255 units) can be made at a maximum of 136.9 T bytes RAID5 (14D+1P) (using the 600 G disk drive).
- One RKM/RKEM connects up to eleven RKAKs or four RKAKXs (Disk Drive: Maximum of 207 units).

In two racks:

- The system configuration which one RKM connect up to 15 RKAK (Disk Drive: Maximum of 240 units) can be made.
- When connecting RKAKX to the RKEM, a system can be mounted up to 255 Disk Drives.

Minimum configurations

The minimum configurations of the AMS 2100 and AMS 2300 are:

- AMS 2100: one base unit containing four SATA or four SAS disk drives
- AMS 2300: one base unit containing four SATA or four SAS disk drives



NOTE: After the minimum configurations are met, both the base and expansion units can be configured with a combination of SAS and SATA drives. The high-density expansion unit supports only SATA drives. See [Disk drive configurations \(page 4-3\)](#) for more information.

Maximum configurations

The maximum configurations of the AMS 2100 and AMS 2300 are:

- AMS 2100: one base unit (15 disk drives) and either seven expansion units (105 disk drives) or one high-density expansion unit (48 disk drives). The maximum number of disk drives, including the base unit is 120. See [Table 1-7](#) for information about combinations of expansion units.
- AMS 2300: one base unit (15 disk drives) and either 15 expansion units (225 disk drives) or four high-density expansion units (192 disk drives) and one expansion unit (15 disk drives (total 222 disk drives) can be connected to an AMS 2300. The maximum number of disk drives, including the base unit is 240. These configurations may require two AMS 2000 racks. See [Table 1-7](#) for information about combinations of expansion units.

Installing an AMS 2100/2300

Installation road map

The following table lists the steps to install an AMS 2100/2300 and provides links and page numbers where the detailed steps are located.

Table 5-3: Installation Tasks

Step	Description	Page
1	<input type="checkbox"/> Unpack the Array	5-24
2	<input type="checkbox"/> Remove the front bezel	5-28
3	<input type="checkbox"/> Mount the unit in rack	5-30
4	<input type="checkbox"/> Turn rack PDBs OFF	5-35
5	<input type="checkbox"/> Connect Fibre Channel host cables and LAN cable	5-40
6	<input type="checkbox"/> Connect power cables	5-49
7	<input type="checkbox"/> Install front bezel	5-55
8	<input type="checkbox"/> Turn rack PDBs on	5-49
9	<input type="checkbox"/> Turn array power on (front panel)	5-53
10	<input type="checkbox"/> Verify that array is ready (check LEDs)	6-4
11	<input type="checkbox"/> Install Navigator 2	7-12

Unpacking an array

Observe the following guidelines to ensure your safety. Failure to follow these guidelines could result in bodily injury or damage to the array chassis or components.



CAUTION! A fully populated AMS 2100/2300 base unit weighs approximately 112 lbs (51 kg) and requires three or more people to lift the array. Before lifting the unit, always turn off the power and unplug all data and power cables.

An expansion unit weighs 88 lbs (40 kg). Use at least two people to unpack and install an expansion unit.

Install the base unit at the bottom of the rack. If the array is mounted at the top of the rack, the rack may become unstable and fall.



- Unpack the unit indoors. Take care not to unpack it in dusty places, in direct sunlight, or where rain or moisture are present.
- Work on the unpacking in the place where a rapid difference of temperature does not occur. It may have dew condensation when it is unpacked in the place where a difference of temperature is extreme.
- Verify that the unpacking and installation of the rack are performed by service personnel.

The array within the outer package is shown in the following illustration.

Complete the following steps to unpack an AMS 2100/2300 array.

1. Remove the outer package and packing materials.
2. Take the array out of the polyethylene bag.
3. Remove tapes, etc. applied to the array.
4. Remove desiccating agent from the lower section of the array.
5. Check the exterior of the array visually for distortion or damage that occurred while the array was being transported to your installation site.

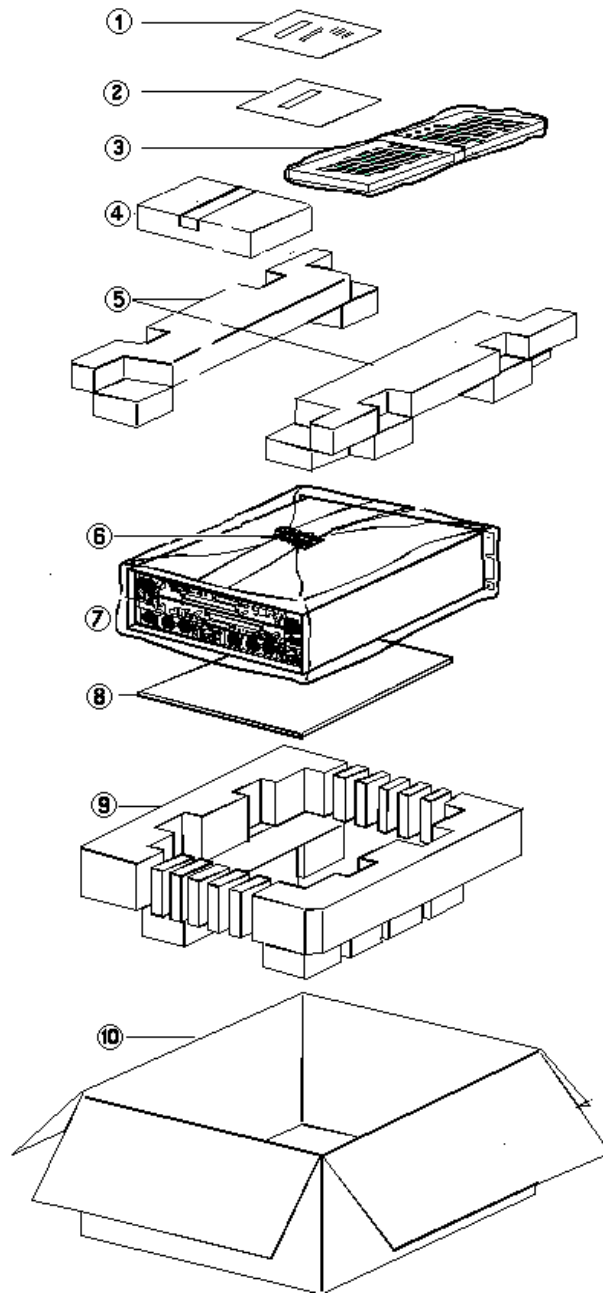

Figure 5-23: AMS 2100/2300 Packaging

Table 5-4: AMS 2100/2300 Packaging

Item	Description	Item	Description	Item	Description	Item	Description
①	Quick Installation Guide	④	Accessory Box	⑦	Base Unit or Expansion Unit	⑩	Shipping container
②	License Agreement	⑤	Buffer Pad (upper)	⑧	Pad		
③	Front Bezel	⑥	Desiccant	⑨	Buffer Pad (lower)		

Checking the contents of the package

- Ensure that the model names, product serial numbers, and quantities of the items in the package agree with the information on the packing list shipped with the array. If any items are missing or damaged, contact the facility where the array was purchased.
- Be sure to keep the key for the front bezel supplied with the array. The key for the front bezel is used for security control and parts replacement. The same key fits all AMS 2100/2300 base and expansion units.

Figure 5-24: Locations of Array Serial Number Markings

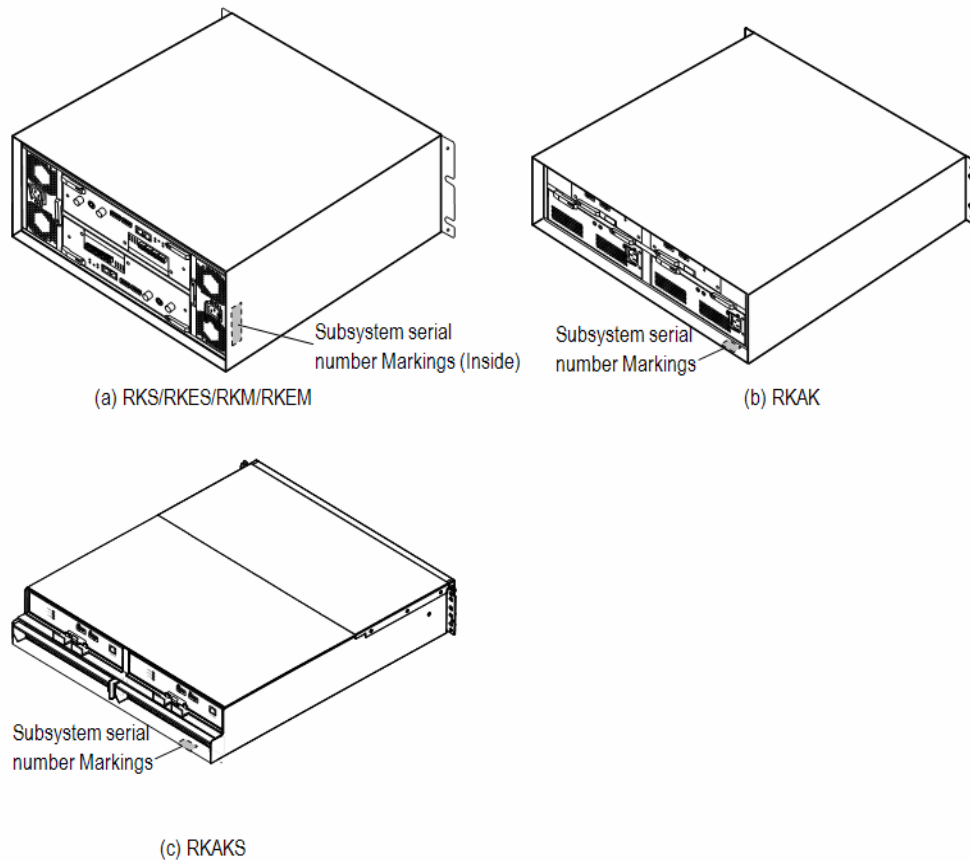

Removing the front bezel

Complete the following steps to remove the front bezel.



CAUTION! Attach and remove the front bezel carefully. Otherwise, you may pinch your fingers between the bezel and the chassis as it snaps closed.



NOTE: The front bezels of the RKS/RKES/RKM/RKEM, the RKAK, and the RKAKS are different sizes.



NOTE: When installing or removing the front bezel, be careful not to operate the main switch or the ON/OFF button of the front bezel.

1. Unlock the front bezel. The key stays in the lock while it is unlocked.



NOTE: If the key is not inserted all the way into the lock before turning it, the key and/or the lock may be damaged when attempting to turn the key.



NOTE: When you turn the key after locking the front bezel, align its groove with the position of the ball catch. If the key is not aligned properly, the lock may be damaged.

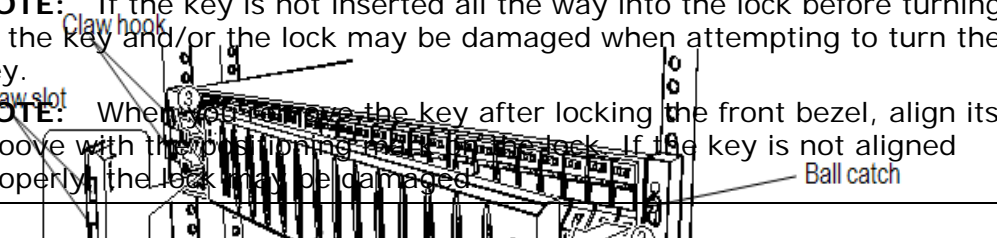

Figure 5-25: Front Bezel Key

2. Grasp the front bezel on both sides and above the center of the unit. Pull the front bezel toward you to disengage it from the ball catches.
3. Disengage the two hooks of the front bezel from the slots on the array chassis by shifting the bezel to the left, and remove the bezel. See [Figure 5-26](#). Also, see the illustrations in Chapter 4 for more details.

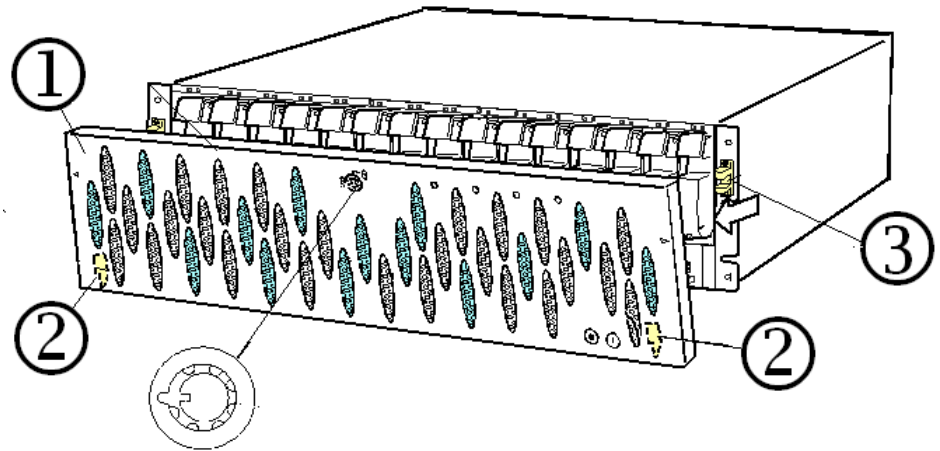

Figure 5-26: Removing the Front Bezel

Table 5-5: Removing the Front Bezel

Item	Description	Item	Description	Item	Description
①	Front Bezel	②	Hook	③	Ball Catches

Removing the front bezel of the modular 2U SAS expansion unit

1. Unlock the front bezel (1). The key stays in the lock while it is unlocked.



NOTE: If the key is not inserted all the way into the lock before turning it, the key and/or the lock may be damaged when attempting to turn the key.



NOTE: When you remove the key after locking the front bezel, align its groove with the positioning mark on the lock. If the key is not aligned properly, the lock may be damaged.

2. Pull the front bezel toward you holding its bottom right portion, and then disengage the right side of the front bezel from the ball catches (2).
3. Pull out the front bezel from the claws on the left side of the subsystem main body to remove the front bezel (3).

Figure 5-27: Modular 2U SAS expansion unit front bezel

Mounting the array in a rack

Attaching an EMI gasket

Complete the following steps to attach an EMI gasket supplied with the rack rail on the top of the base and expansion units.

1. Peel off the anti-adhesion sheet from the bottom surface of the EMI gasket.
2. Attach an EMI gasket at the front of the base unit, and at both the front and rear of the expansion unit(s) as shown in the following figures. Align the gaskets with the front and rear edges of the unit.
3. Install the array in the rack. See [Mounting the array](#) on the next page

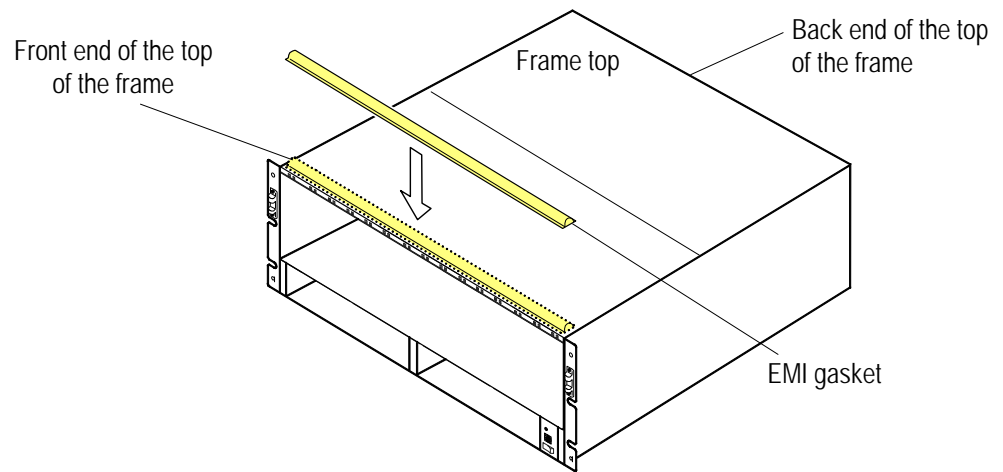

Figure 5-28: Position for Attaching EMI Gasket (Base Unit)

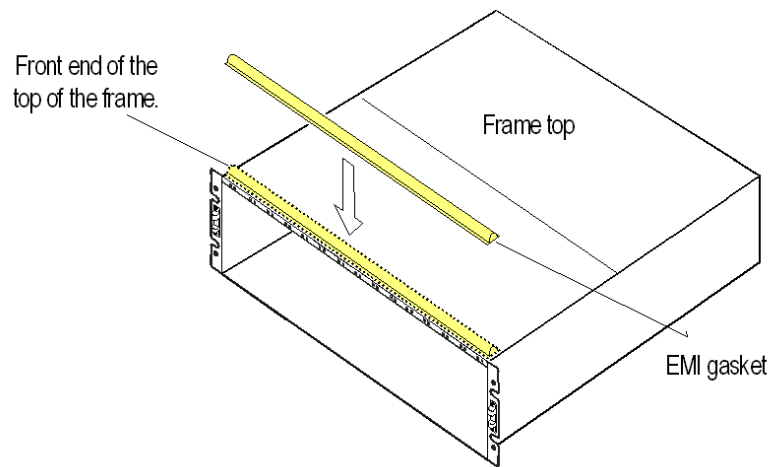

Figure 5-29: Position for Attaching an EMI Gasket (Expansion Unit)

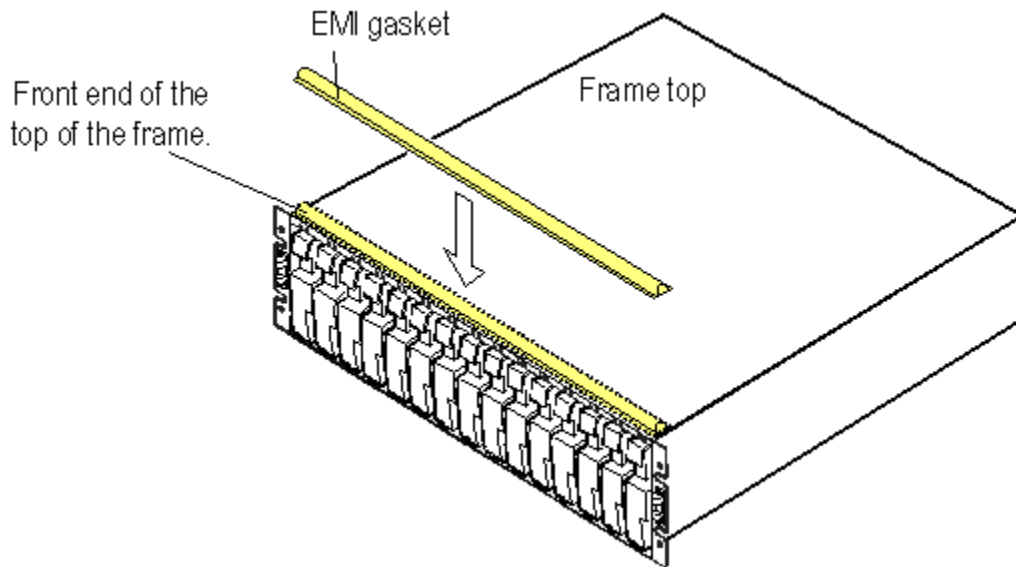

Figure 5-30: Position for Attaching an EMI Gasket (RKAKS Expansion Unit)

Mounting the array

Please read all of the following safety information before mounting an array in a rack. More detailed safety instructions are included at the beginning of this chapter.



NOTE: Rack rails should be installed in the rack by qualified personnel before installing the array.



CAUTION! Do not block the vent holes in the rack or any of the units. Without adequate cooling, the array may overheat or fail. Install the array so that the air intakes and the air exhaust remain clear. See [Installation area and service clearance](#) for details.



CAUTION! Do not move the lifter away from the rack or lower the elevator until the red line on the label affixed to the subsystem enters the rack across the end of it. Otherwise, the subsystem may fall.



WARNING!

- Be careful when lifting the array, especially if it is being installed high up in the rack. It could cause serious injury or damage if it falls.
 - Hitachi Data Systems recommends using mechanical lifting equipment to help install the array. However, the equipment should be operated only by trained and qualified personnel.
 - When using a mechanical lift to help install the array, do not move the lift away from the rack or lower the elevator until the red line on the label attached to the array is inside the rack. Otherwise, the array may fall.
 - When lowering the elevator on a hydraulic lift, open the valve slowly. If you open the valve quickly, the elevator could drop rapidly and may cause personal injury.
 - When a mechanical lift is not available, use at least three people to install the array into the rack.
 - Work carefully when positioning, fastening, or performing any other operations on the array. The base unit weighs 112 lbs (51 kg), the RKAK expansion unit weighs 88 lbs (40 kg), and the RKAKS expansion unit weighs 23 kg. Whenever possible, install the base units near the bottom of the rack. This helps to prevent the rack from falling over.
-

To mount the array in a rack:

1. Lift the array only up to the height needed to mount it in the rack.
2. Adjust the position of the array so that it is centered between the rack rails and vertically aligned to the rails onto which it will be mounted.
3. Gently slide the array onto the rails in the rack.

Fastening the array to the rack

1. As shown in [Figure 5-31](#), fasten the array to the rack rails with four M5×10 binding screws provided with the rack.

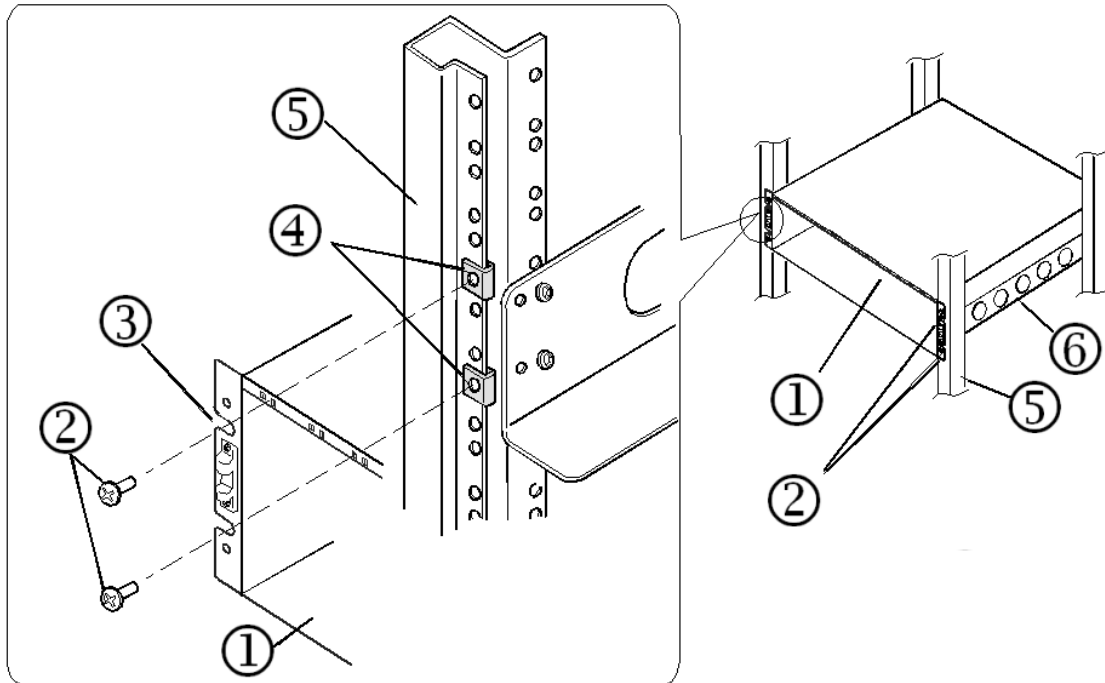

Figure 5-31: Fastening Front Side of the Array

Table 5-6: Fastening Front Side of the Array

Item	Description	Item	Description	Item	Description
①	Array	③	Mounting Slot	⑤	Rack
②	Mounting Screw, M5-10	④	Nut	⑥	Rail

2. As shown in [Figure 5-32](#), fasten the rear side of the array to the rack rails.
3. Shift each of the two stoppers in the direction shown by the arrow and make it contact the frame.
4. Tighten the binding screws.

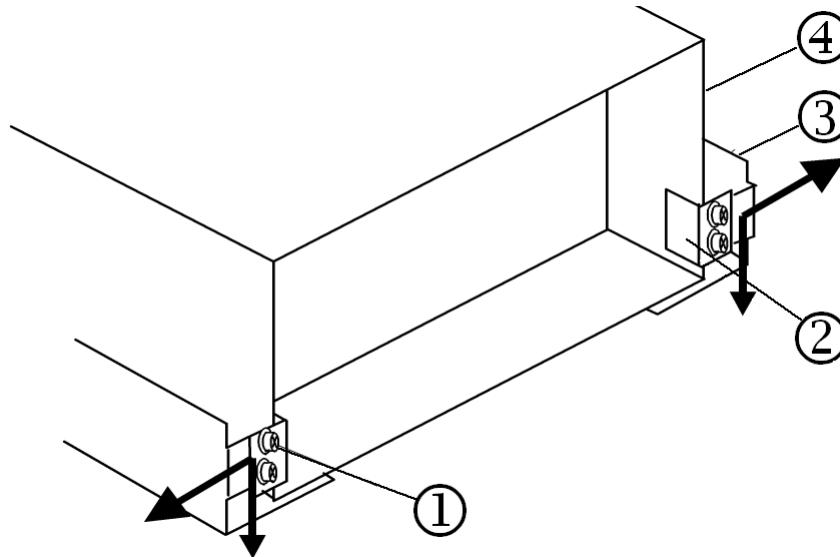

Figure 5-32: Securing Rear of the Array

Table 5-7: Securing Rear of the Array

Item	Description	Item	Description	Item	Description	Item	Description
①	Binding Screw	②	Stopper	③	Rail	④	Frame

Connecting cables

This section provides information and instructions to connect and route power cables, ENC cables, Fibre Channel cables and iSCSI cables.



CAUTION! Be careful to connect cables correctly. Leave a service loop in each cable to facilitate maintenance and prevent it from being stretched or pulling on the connectors, and to leave some slack in case of an earthquake.

Use the cable routing bars that are provided with the high-density expansion unit to route power and ENC cables to protect them from being bent too sharply or tangled and caught when the unit is moved within the rack.

Before connecting power cables to the array, make sure that the circuit breakers on the PDBs (power distribution busses) are turned OFF.

Connecting ENC cables (expansion unit)

This section covers the expansion unit. See the next section for information to connect cables to a high-density expansion unit.

Use the ENC cables supplied with the expansion unit to connect an ENC unit in an expansion unit to the base unit controller(s) and/or to other expansion units or high-density expansion units. Two ENC cables are supplied with each expansion unit.



CAUTION! The connectors on the ends of an ENC cable are different. Check the label on the connector before plugging it in. ENC connectors are designed to slide easily into the connector on the ENC unit. If a connector does not plug in easily, check the connector to make sure you have the correct end of the cable.



CAUTION! Additional chassis must be connected in order of Path number and unit ID number. For details, refer to [Chapter 11, Connection configuration restrictions](#).

As shown in [Figure 5-33](#), the connector that plugs into the control unit on a base unit is stamped with a diamond. This connector can also plug into an OUT connector on an ENC unit. The connector that plugs into the IN connector on an ENC unit is stamped with a circle.

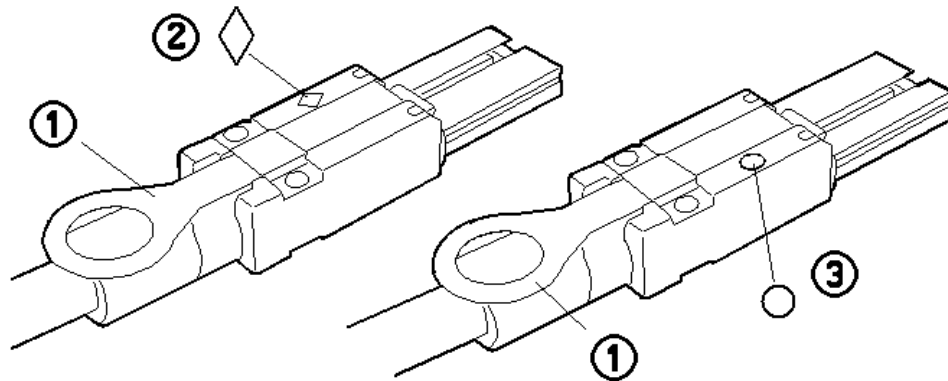

Figure 5-33: ENC Connectors

Table 5-8: ENC Connectors

Item	Description	Item	Description	Item	Description
①	Lock Tab (pull tab to unlock connector before unplugging it)	②	Diamond stamp on controller and ENC OUT end of cable	③	Circle stamp on ENC IN end of cable.

- When two or more expansion units are connected, both cables in ENC unit #0 and ENC unit #1 should be connected to the expansion unit.
- If it is necessary to bend an ENC cable to connect it, keep the bend radius as large as practical, and not less than 30 mm. This prevents excessive stress on the cable and the connector.

- The IN and OUT connectors on the ENC units have blue and green labels, respectively.

Complete the following steps to install the ENC cables. Refer to the following two illustrations ([Figure 5-34 \(page 5-38\)](#) and [Figure 5-35 \(page 5-39\)](#)) when installing ENC cables.

1. Remove the rubber cap from the ENC connector on the control unit.
2. Connect the ENC cable to the control unit.
3. Connect the ENC cable to the ENC unit of the expansion unit.



NOTE: Connect control unit#0 of the base unit with the ENC unit #0 of the expansion unit (RKAK) and the control unit#1 of the base unit with the ENC unit #1 of the expansion unit (RKAK).

4. Connect the cable marked in milky white from PATH#0 of the base unit to the IN side of the ENC unit of expansion unit (Unit ID#1).
5. When three or more expansion units are mounted, connect the connector labeled OUT and the connector labeled IN on the ENC unit of the expansion units (RKAKs) using the ENC cables.
 - a. Remove the rubber cap of the ENC units in the locations where the ENC cables are to be connected.
 - b. Connect each of the connectors with the ENC cables to the OUT side and the IN side of the ENC unit from which the rubber cap was removed.
6. After connecting the ENC cables, roll up the excess part of each cable in a circle and tighten it lightly with the velcro tie.



CAUTION! To prevent electromagnetic interference from a power cable, to the signals in an ENC cable, do not route power cables near an ENC cable.

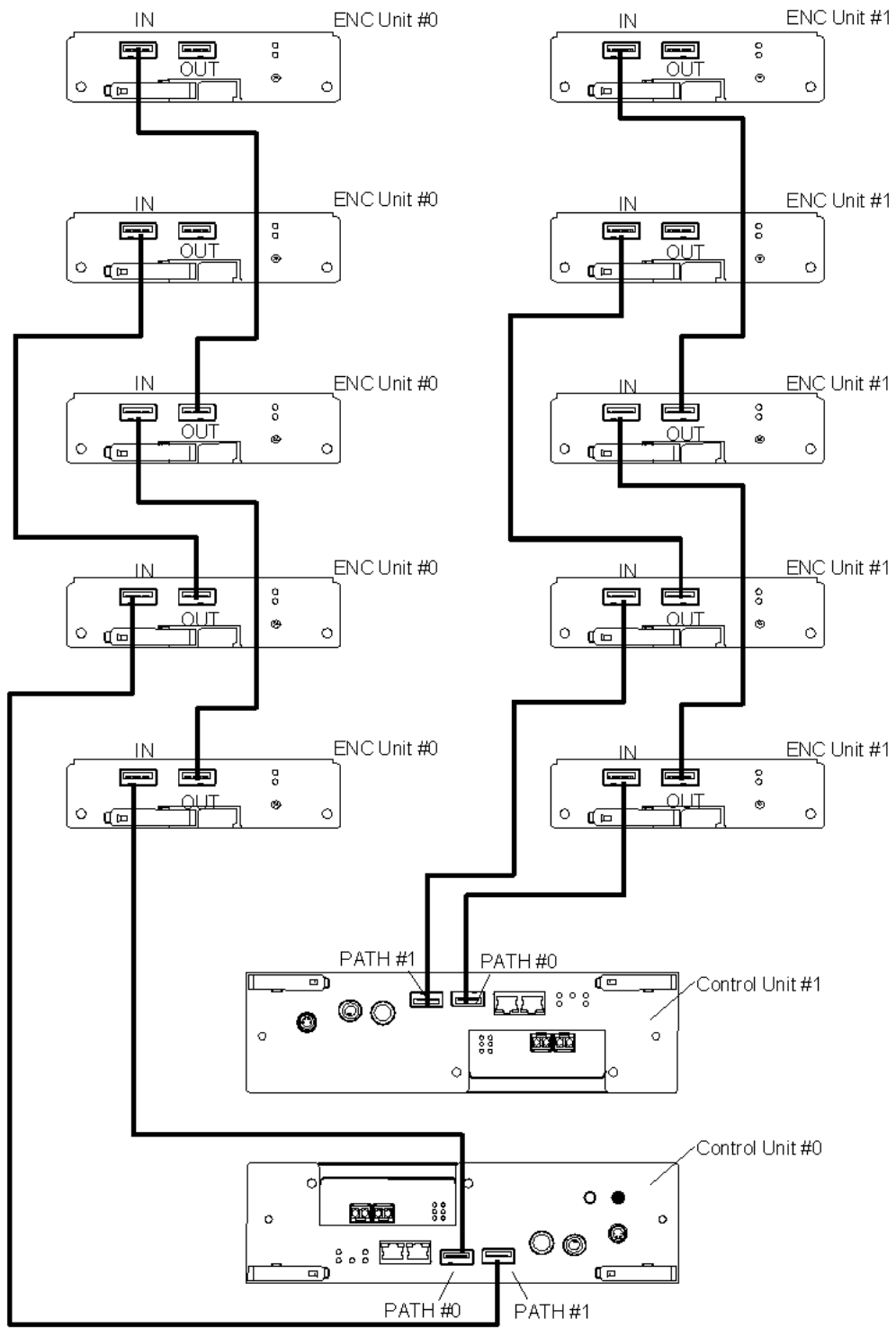

Figure 5-34: Connecting ENC Cables from an AMS 2100 to the Expansion Units

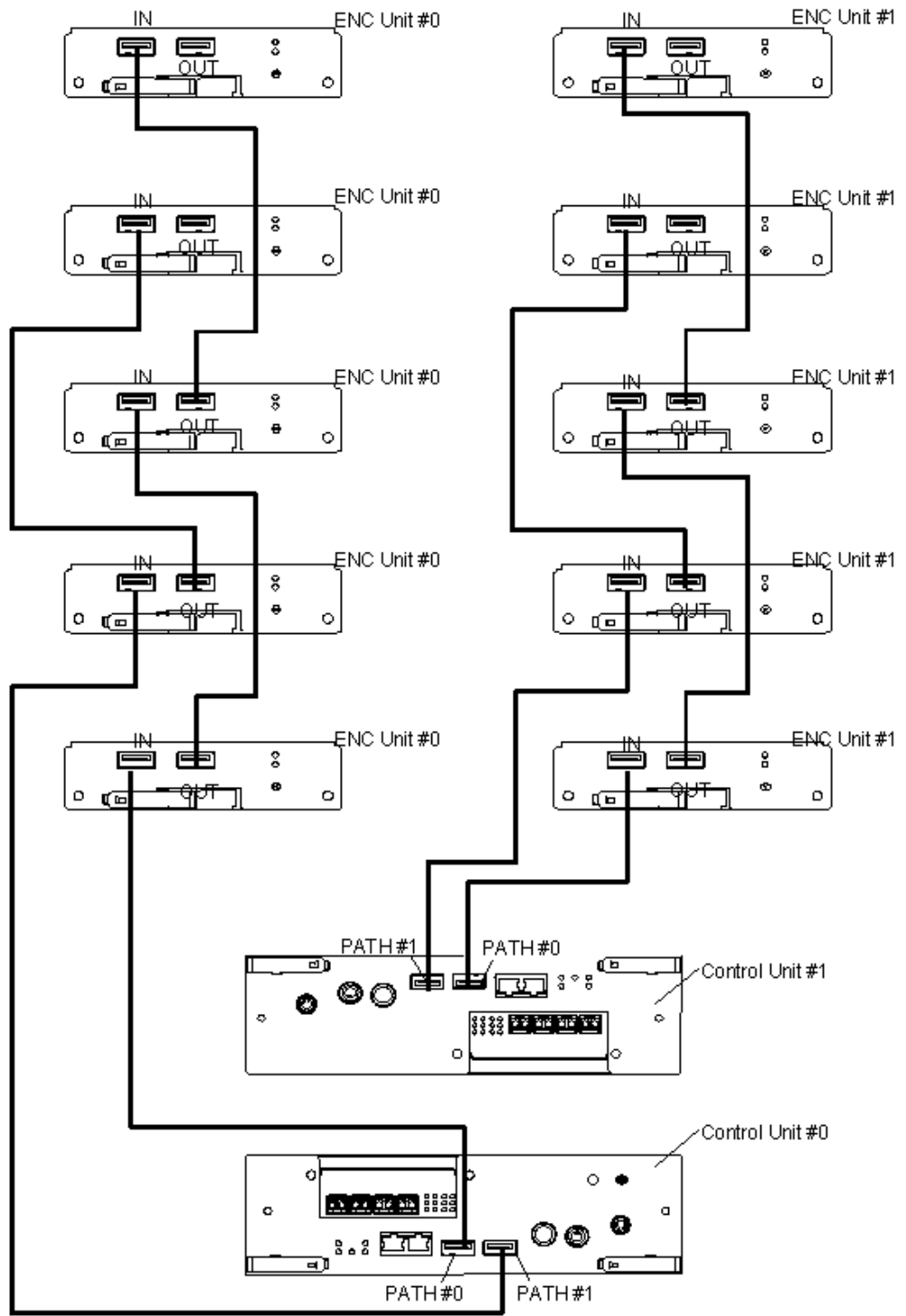

Figure 5-35: Connecting ENC Cables from an AMS 2300 to the Expansion Units

Connecting ENC cables (high-density expansion unit)

This section provides basic instructions to connect ENC cables to the high-density expansion unit. See the previous section for information to connect cables to a standard storage expansion unit.



NOTE: The following information is provided for convenience to HDS service personnel and HDS partners who are authorized to perform these procedures. Complete instructions are located in the AMS 2000 Maintenance Manual.

Use the ENC cables supplied with the high-density expansion unit to connect an ENC unit in a high density expansion unit to the base unit controller(s) and/or to other expansion units or high-density expansion units. Two ENC cables are supplied with each high-density expansion unit.



CAUTION! The connectors on the ends of an ENC cable are different. Check the label on the connector before plugging it in. Enc connectors are designed to slide easily into the connector on the ENC unit. If a connector does not plug in easily, check the connector to make sure you have the correct end of the cable.

As shown in [Figure 5-36](#), the connector that plugs into the control unit on a base unit is stamped with a diamond. This connector can also plug into an OUT connector on an ENC unit. The connector that plugs into the IN connector on an ENC unit is stamped with a circle.

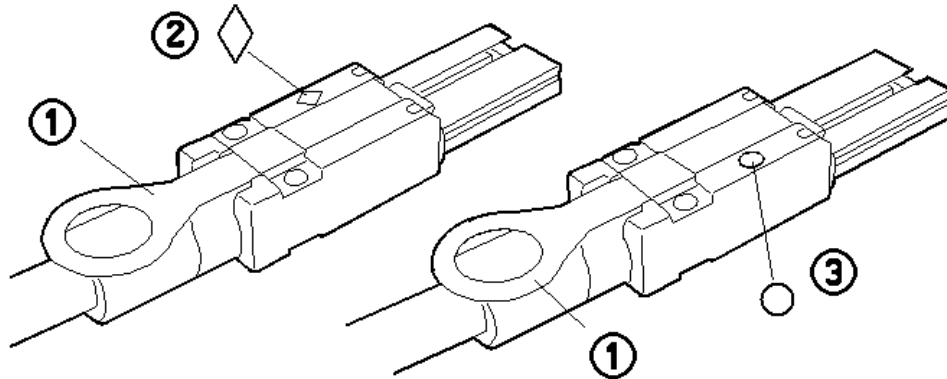

Figure 5-36: ENC Connectors

Table 5-9: ENC Connectors

Item	Description	Item	Description	Item	Description
①	Lock Tab (pull tab to unlock connector before unplugging it)	②	Diamond stamp on controller / ENC OUT end of cable	③	Circle stamp on ENC IN end of cable.

**NOTE:**

- When two or more expansion units are connected, both cables in ENC unit #0 and ENC unit #1 should be connected to the high-density expansion unit.
 - If it is necessary to bend an ENC cable to connect it, keep the bend radius as large as practical, and not less than 30 mm. This prevents excessive stress on the cable and the connector.
 - The IN and OUT connectors on the ENC units have blue and green labels, respectively.
-

Complete the following steps to install the ENC cables on a high-density expansion unit. Note that the ENC cable does not plug directly into the ENC unit in the high-density expansion unit.

1. Install the ENC cable in the high-density expansion unit cable holder, as shown in [Figure 5-37](#).



Figure 5-37: ENC Cable Holder

2. Remove the rubber cap from the ENC connector on the control unit.
3. Connect the ENC cable to the control unit.
4. Route the cable through the cable routing bars to the appropriate high-density expansion unit. See [Figure 5-38](#) and the diagrams in the installation chapter in the maintenance manual.



Figure 5-38: ENC Cable Routing on High-density Expansion Unit



NOTE: The cable routing bars are used to protect the cables from being bent too sharply and becoming caught or tangled when the high-density expansion unit is moved in the rack as needed to replace disk drives and or ENC units.

5. Open the lock lever on the ENC cable holder and slide the cable holder into the appropriate slot on the high-density expansion unit. See [Figure 5-39](#).

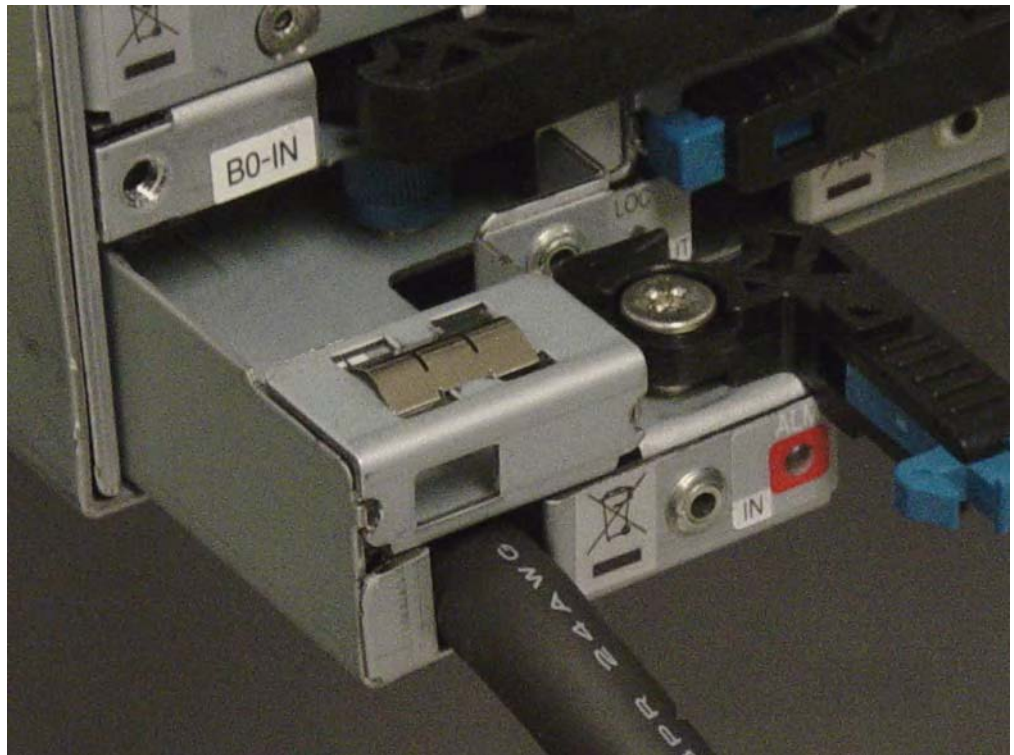

Figure 5-39: Connecting an ENC Cable to a High-density Expansion Unit

6. Slide the cable holder all the way into the high-density expansion unit. As you do so, the lock lever will close part way.
7. Push inward on the lock lever to close it. Ensure that the lock button snaps into place and locks the lever closed.

Cable routing diagrams

The following diagrams show examples of how to connect ENC cables from an AMS 2100/2300 to a variety of expansion unit and high-density expansion unit configurations.

High-density Exp Unit #3



High-density Exp Unit #2

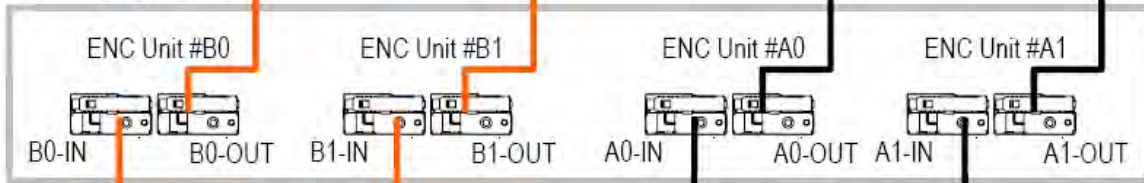

High-density Exp Unit #1

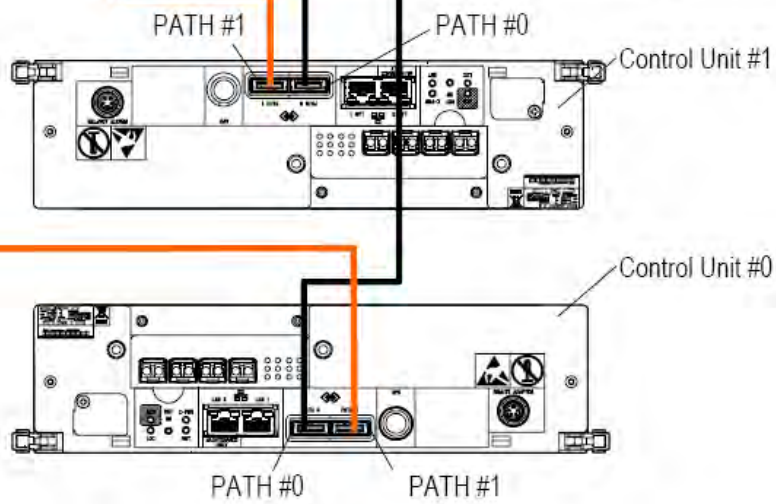
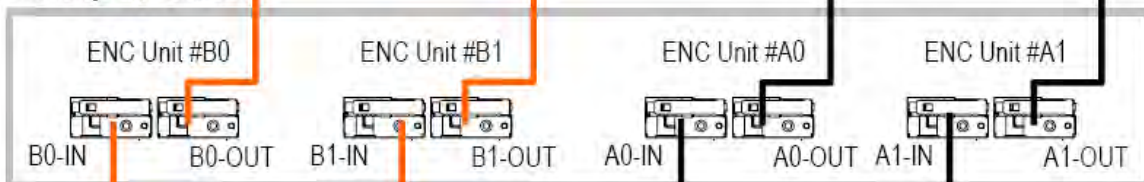

Figure 5-40: Connecting ENC Cables, AMS 2100/2300 and Three High-density Expansion Units

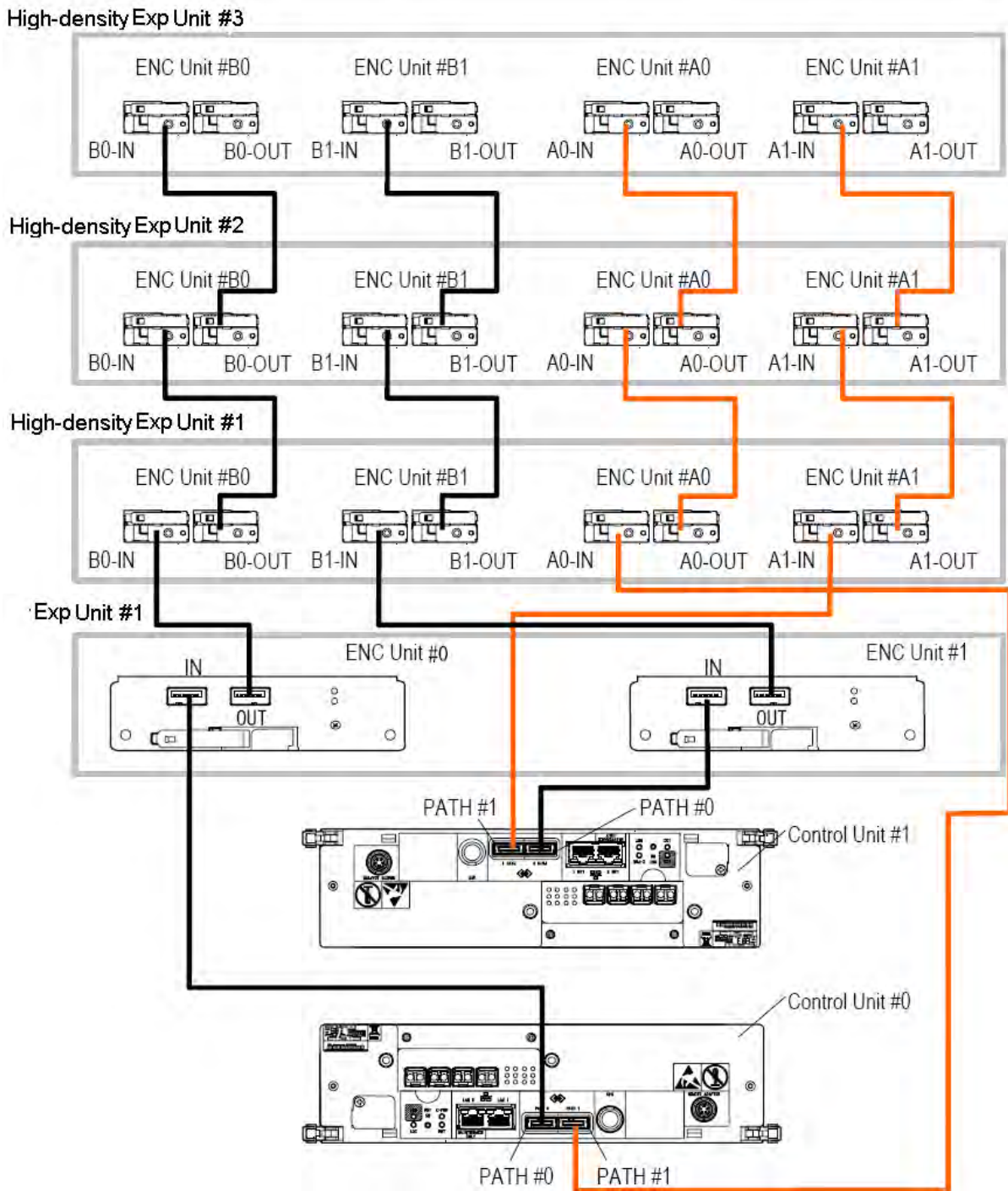

Figure 5-41: Connecting ENC Cables, AMS 2100/2300, one Expansion Unit, and Three High-density Expansion Units

Expansion Unit #2

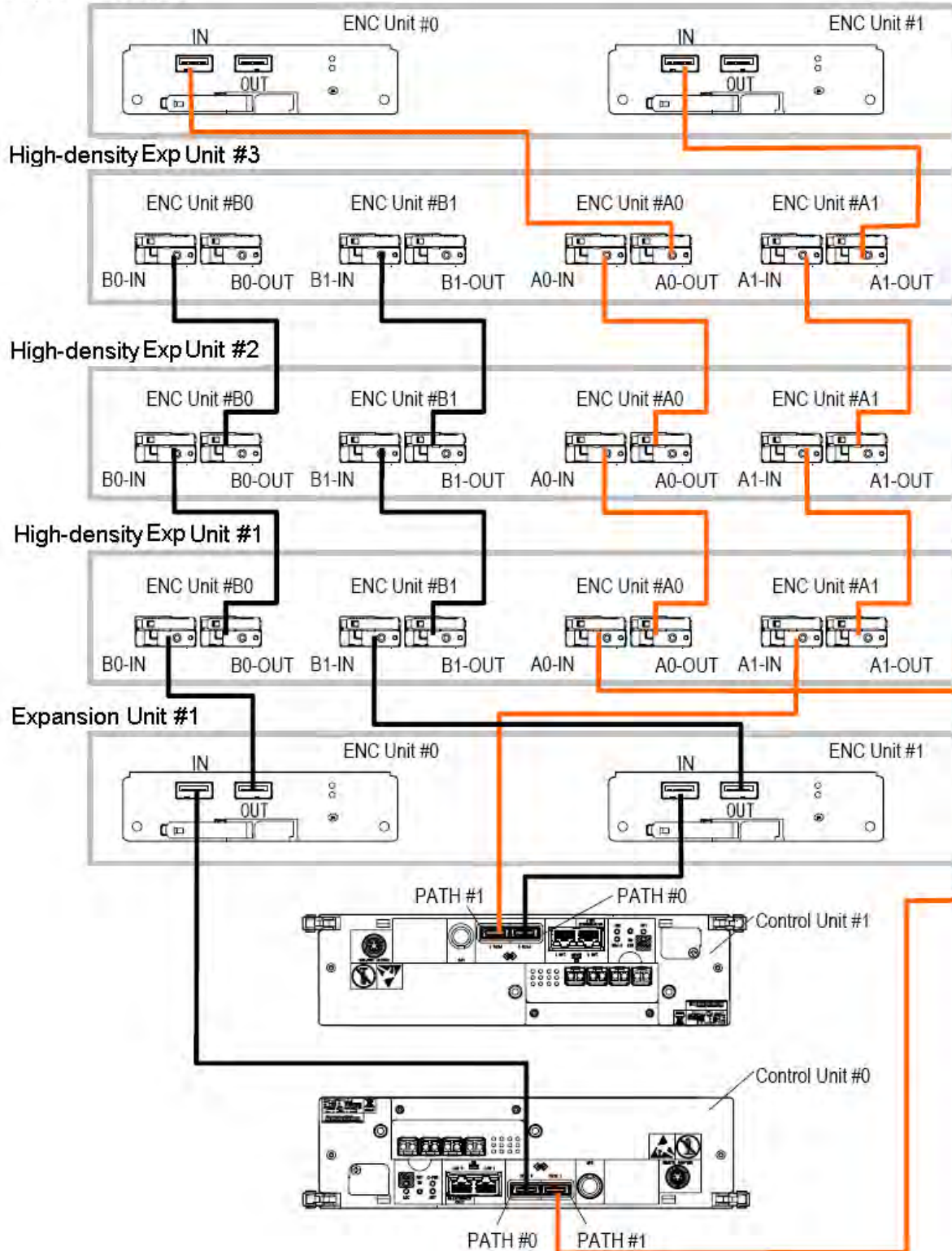

Figure 5-42: Connecting ENC Cables, AMS 2100/2300, two Expansion Units, and three High-density Expansion Units

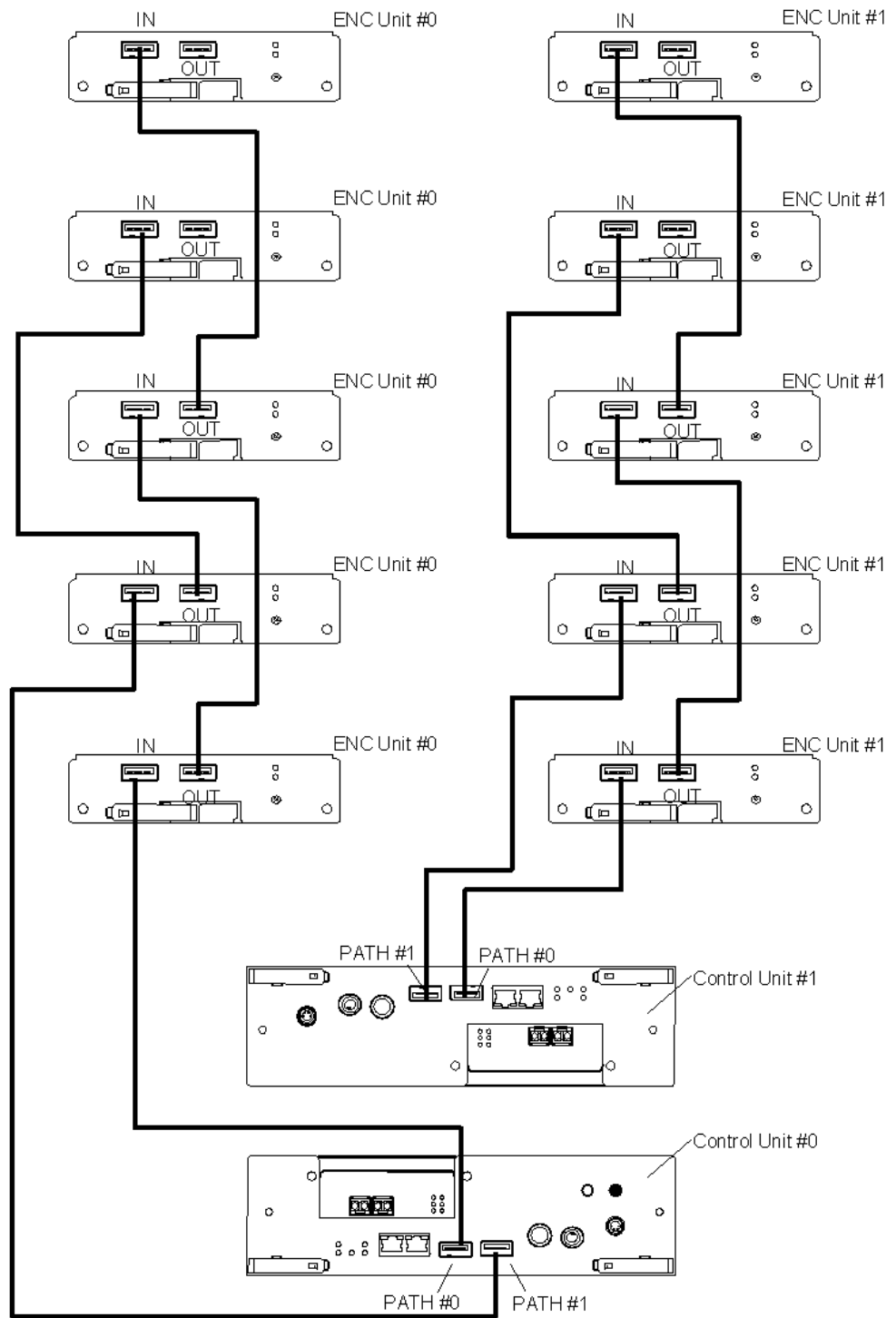

Figure 5-43: Connecting ENC cables to the RKH/RKEH and 20 RKAKS

Connecting a LAN cable



CAUTION! To prevent electromagnetic interference from a power cable to the signals in an ENC cable, do not route power cables near an ENC cable.

1. Connect a customer-provided CAT 5 or CAT6 Ethernet LAN cable to the management LAN port on the control unit #0 or control unit #1 in the array.
2. Connect the other end of the LAN cable to a customer provided LAN-HUB or to the LAN port on the management PC.



- Use LAN crossover cables when connecting to the LAN-HUB with 10/100BASE-T (Category 5 or 6). Use straight LAN cables when connecting the array directly to a management PC.
- The default IP address for the user LAN port on the control unit #0 is 192.168.0.16. The default IP address for the user LAN port on the control unit #1 is 192.168.0.17.

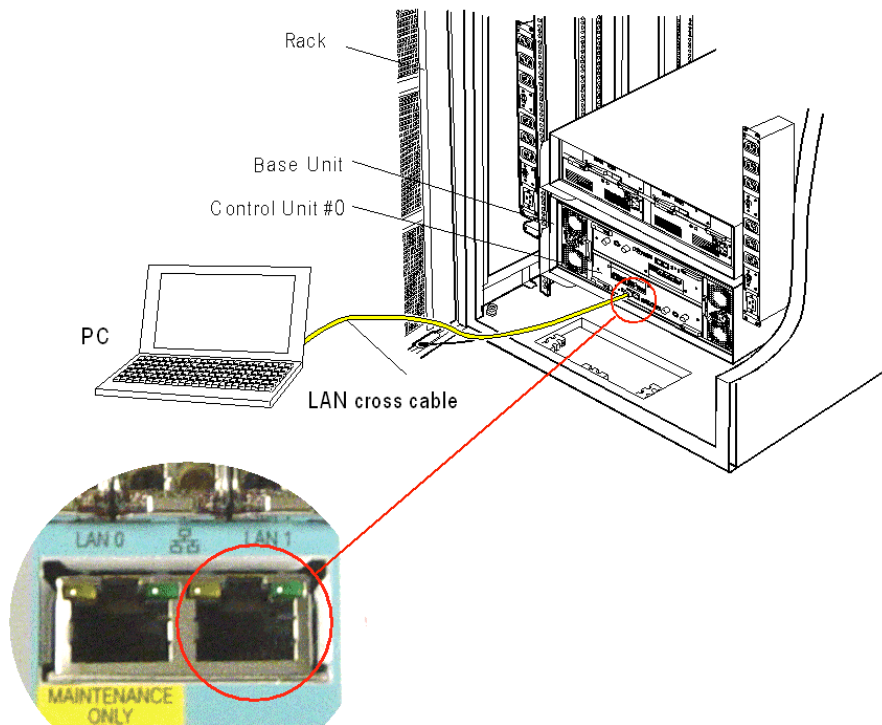

Figure 5-44: Connecting the LAN Cable

Connecting power cables

Complete the following steps to connect power cables to the rack PDB.

Check that the PDB power cables connection is performed by the service personnel.



CAUTION! Check all power cables for cuts or cracks in the insulation before using them. Replace the cable as needed.



CAUTION! When inserting the power cable in the connector of PDB, insert it completely, and then secure it with a cable clamp, etc. If it is loosened, the connection is damaged, and it causes an electric shock or fire.



NOTE: Make sure that conductors are provided with 30 A overcurrent protection in accordance with Article 240 of the National Electrical Code, ANSI/NFPA 70, and the Canadian Electrical Code, Part 1, CSA C22.1, Section 14.

1. Make sure that the switch or breaker on each PDB in the rack has been turned off.
 2. Insert the power cable plug into the receptacle on each power supply. Use the PDB receptacles in the order from the J101 to J103.
 3. Secure the power cable retainers onto the power cables to prevent them from accidentally pulling away from the receptacles.
 4. Plug the power cable connected to power supply #0 into a PDB on the left side of the rack and plug the power cable from power supply #1 into the PDB on the other side of the rack. This ensures that the power supplies are connected to different AC sources and are therefore redundant.
-



CAUTION! If both power supplies are connected to the same power source, both will fail if the AC power fails and the unit will also fail.

- Do not plug any power cable other than a power cable from the mounted array to an outlet on the PDB.
- Make sure that the load on both of the PDBs in a rack does not exceed 16 amps.
- Connect the power cables so that the load on a PDB does not exceed 16 amps after checking the load through a calculation
- Limit the load on each PDB in the rack to 8 amps. Use the following values to calculate the load:

Table 5-10: AMS 2100/2300 Power Requirements

Unit	Current at 100 - 120VAC
AMS 2100 Base Unit	3.8 Amps

Table 5-10: AMS 2100/2300 Power Requirements

Unit	Current at 100 - 120VAC
AMS 2300 Base Unit	3.8 Amps
Expansion Unit	2.4 Amps
High-density Expansion Unit	3.7 Amps

1. After inserting a plug into a socket on a PDB, install the cable clamp to prevent it from accidentally becoming unplugged.



NOTE: When using PDB without a cable clamp, ensure that the power cable is firmly fixed to the rack with repeat binders, etc. to prevent the connector from coming off.

2. Route the power cables.
3. Recheck the power cable plug to make sure it is still secure in the PDB and that it has not become loosened during the cable routing. See [Figure 5-45](#).

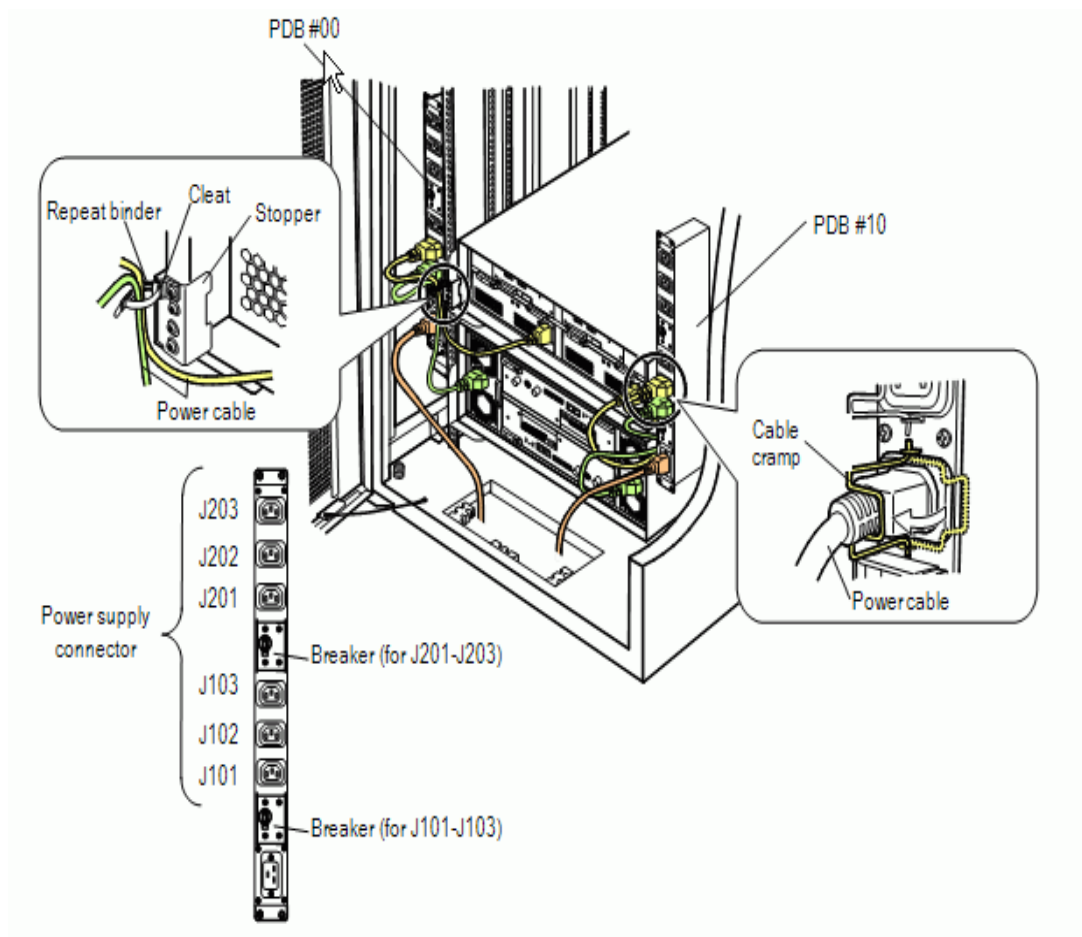

Figure 5-45: Connecting Power Cables (Rack PDB)

Connecting Fibre channel cables

Two types of Fibre Channel interface cables are provided to connect the base unit to the HBA (Host Bus Adapter) on the host computer. Table 5-11 describes the connector shapes and cable types. Choose the applicable cables from the table for your installation.

Table 5-11: Connecting the Fibre Channel Interface Cables

Fibre Channel Interface Side (AMS 2100 / AMS 2300 (RKS/RKM side))			Host computer side (HBA (Host Bus Adapter), SW)	Types of Cables to be Connected	
Parts Name of Connected Cable Plug	Model	Connector Form	Connector Form	Cable Connector Shape	Model
Control Unit (including Fibre Channel Interface board)	DF-F800- F1KS (RKS)	LC	SC	LC-SC cable	A-6515-GMxS ¹
	DF-F800- F1KES (RKES)		LC	LC-LC cable	A-6515-GMxL ¹
	DF-F800- F1KM (RKM)	LC	SC	LC-SC cable	A-6515-GMxS ¹ A-6515-HMxS ¹
	DF-F800- F1KEM (RKEM)		LC	LC-LC cable	A-6515-GMxL ¹ A-6515-HMxL ¹

1. "x" denotes a value (1 to 300) that shows a cable length.

Complete the following steps to connect the Fibre Channel cables.



NOTE: When bending Fibre Channel cables, keep the radius of the bend to at least 1.2 inches (30 mm) to prevent cracking or breaking the fibre optic conductor.

1. Connect the Fibre Channel cables from the host systems to the desired Fibre Channel ports (host connectors) on the AMS 2100/2300 control unit. Insert the connectors on the cables until they are securely fastened to the host connectors and the lock snaps into place.

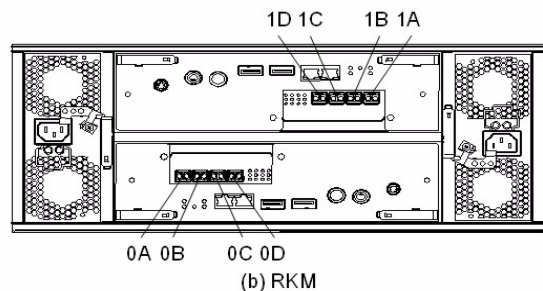
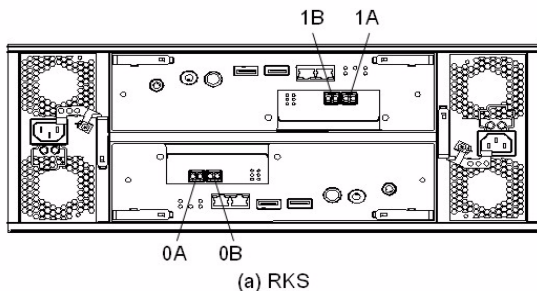

2. Pull all the Fibre Channel cables into the rack, passing them through an opening for cables on the bottom plate of the rack.
3. Using the reusable cable ties provided, bind the cables together and fasten them securely to the rack at enough places to keep the cables close to the rack over their entire length. Leave extra length for each cable so that the connectors will not be pulled out of the sockets. See [Figure 5-46](#).

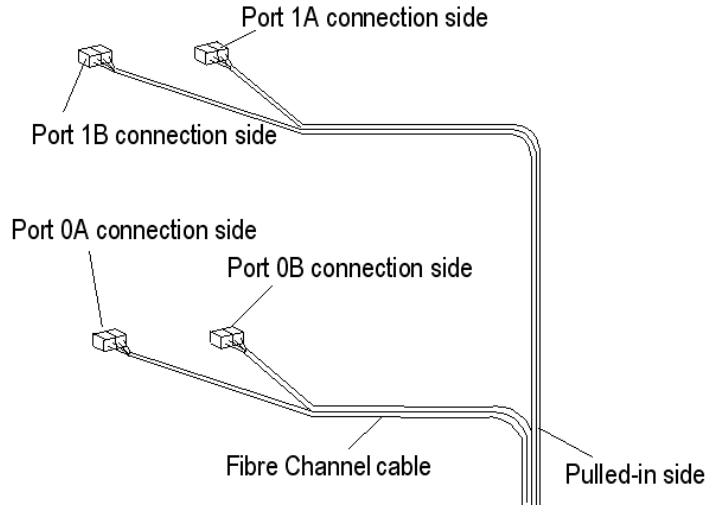

Figure 5-46: Binding Fibre Channel Cables Together.

Connecting iSCSI cables

Complete the following steps to connect the iSCSI cables.



NOTE: When bending iSCSI cables, keep the radius of the bend to at least 1.2 inches (30 mm) to prevent cracking or breaking the fibre optic conductor.

1. Connect the iSCSI cables from the host systems to the desired iSCSI ports on the AMS 2100/2300 control unit. Insert the connectors until the lock snaps into place.

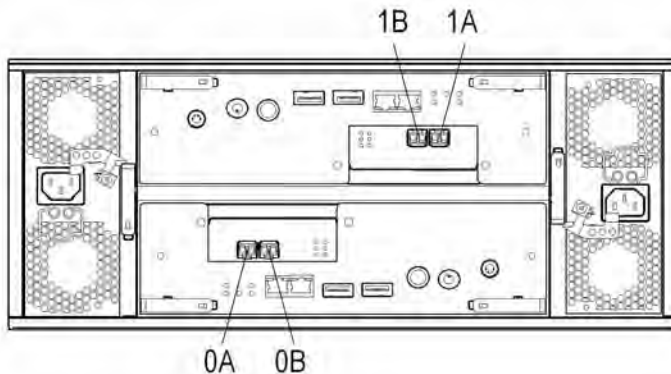

Figure 5-47: iSCSI Interface Cable Connection Ports

2. Pull all the iSCSI cables into the rack passing them through the opening for cables on the bottom plate of the rack.

- Using the reusable cable ties provided, bind the cables together and fasten them securely to the rack at enough places to keep the cables close to the rack over their entire length. Leave extra length for each cable so that the connectors will not be pulled out of the sockets. See [Figure 5-48](#).

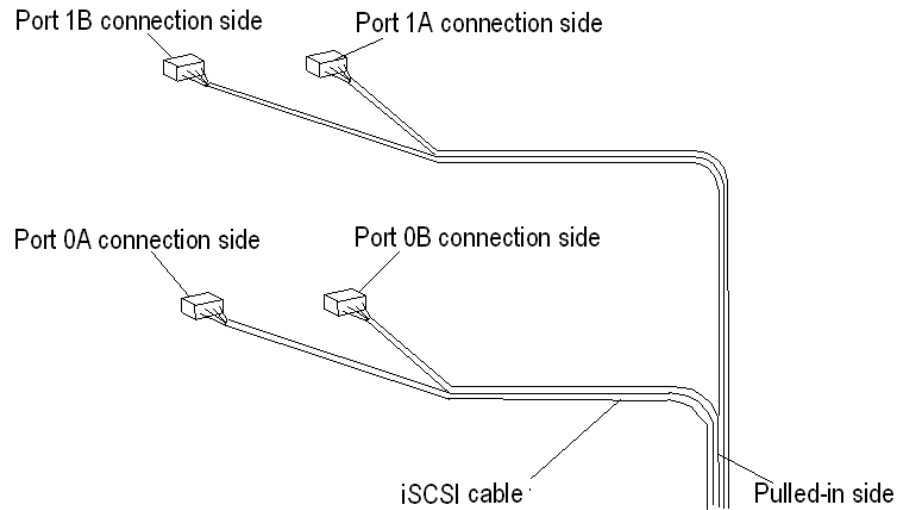

Figure 5-48: Binding iSCSI Cables Together

Turning the array ON

Turn the power switch or circuit breakers in the power distribution busses in the rack ON.

Turn the array power ON. See the instructions in [Chapter 6, Power On/Off procedures](#).

Adding a disk drive



NOTE: Disk drives should be installed with the unit running and with the ready LED ON. Do not install a drive when any of the status LEDs on the front panel are blinking or when the Alarm LED is on.

Task overview

- Remove only ONE dummy disk drive.
- Within 10 minutes after you remove the dummy disk drive, install a new disk drive in the empty slot.
- Repeat steps 1 and 2 for each drive you add to the array.

Installing a disk drive



Static-sensitive. Ground yourself before touching.

- To prevent part failures caused by an electrostatic discharge (ESD) from your body, wear an anti-static wrist strap any time you are handling unprotected parts, including while you are unpacking, removing, or installing them.
 - When you install a component, support its metal frame with one hand and touch the metal frame with the hand that is wearing the wrist strap.
-



CAUTION! Remove only one component at a time from an operating array. Removing more than one component can cause too much cooling air to be lost from the array. After several minutes, this can cause the array to overheat or fail.

To add a disk drive to a unit:

1. Remove the dummy disk drive from the slot where you want to install a new drive.
2. Remove the new disk drive from its static-protective container.
3. Check the model number on the drive and make sure that it is the correct model, type (SAS/SATA), capacity, and speed for the array.
4. Insert the disk drive into the desired slot.
 - a. Fit the disk drive in the guide rail of the AMS 2100/AMS 2300/ expansion unit (RKS/RKM/RKAK), and slide it in the direction shown by the arrow.
 - b. Pull outward on the bottom of the lock tab to unlock the lock lever. Then pull outward on the top of the lock lever until that tab on the bottom is nearly horizontal.
 - c. Push the drive into the slot until it reaches the position where the tab at the bottom of the of the lock lever can be entered into the slot at the lower part of a frame on the front side of the disk array unit.
 - d. Push the lock lever inward, toward the unit in which the drive is installed until the lock tab snaps closed. Push inward on the lock tab to make sure it is locked.



NOTE: If the lock lever is closed too far when you insert the drive, the tab at the bottom of the lever will hit the edge of the unit frame when you try to install the drive. If this happens, open the lock lever enough to raise the tab and slide the drive inward until the tab can be inserted into the slot in the frame.

5. Pull the handle lightly to make sure that the disk drive cannot be accidentally pulled out of the unit.
6. Install a dummy disk drive in each disk drive slot in which no disk drive is installed. Insert it into the slot slowly so that the latch on the dummy disk drive is on the right side when the drive is installed.

Attaching a front bezel

Complete the following steps to attach the front bezel to the array chassis.



CAUTION! Attach and remove the front bezel carefully. Otherwise you may pinch your fingers between the bezel and the chassis as it snaps closed.



NOTE: When installing or removing the front bezel, be careful not to operate the main switch or the ON/OFF button of the front bezel.



NOTE: You must unlock the front bezel before you can install it. The key for the front bezel is required to unlock it.

1. Insert the key into the keyhole on the front bezel and release the lock.
2. Grasp the front bezel on both sides and above the center of the unit.
3. Engage the two hooks of the bottom of the front bezel into the slots on the array chassis. See [Figure 5-49](#).
4. Push the top of the front bezel toward the chassis to engage it into the ball catches.

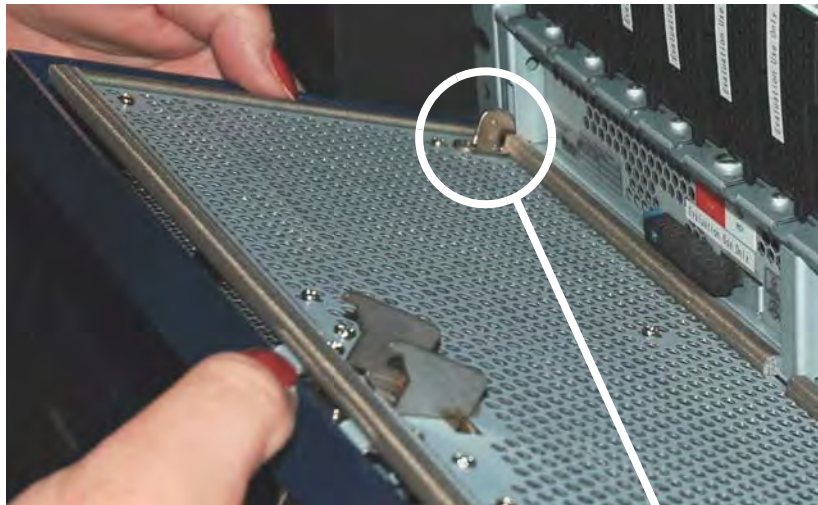

Figure 5-49: Installing a Front Bezel



NOTE: Insert the key all the way into the lock before turning it. If the key is not inserted all the way, the key or the lock may be damaged when attempting to turn the key.



5. Remove the key from the front bezel and store it in a safe place.
 - When removing the key after locking up the front bezel, pull it off aligning its groove with the positioning mark on the lock.
 - When the key is pulled off in the state where its groove is not correctly aligned with the positioning mark on the lock, damage to the lock might occur.

Attaching a modular 2U SAS extension unit front bezel

Complete the following steps to attach the front bezel to the array chassis.



CAUTION! Attach and remove the front bezel carefully. Otherwise you may pinch your fingers between the bezel and the chassis as it snaps closed.



NOTE: When installing or removing the front bezel, be careful not to operate the main switch or the ON/OFF button of the front bezel.



NOTE: You must unlock the front bezel before you can install it. The key for the front bezel is required to unlock it.

1. Grasp the front bezel on both sides and above the center of the unit.
2. Insert the claw on the front side of the subsystem main body into the claw hole in the front bezel (1).
3. Engage the front bezel by pressing the right side of the front bezel to engage the hook of the front bezel with the ball catch (2).
4. Lock the front bezel with the key (3).

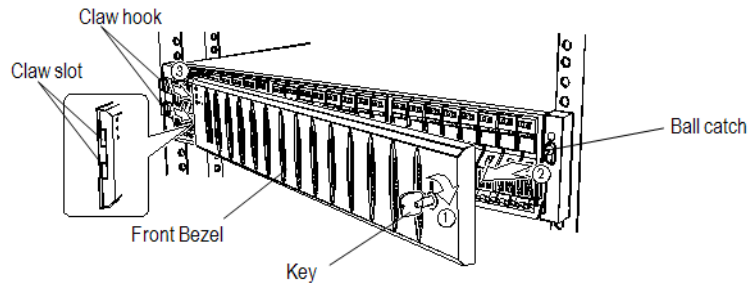

Figure 5-50: Attaching the modular 2U SAS expansion unit

Installing Storage Navigator Modular 2

Detailed information about Navigator 2, including features, installation instructions, and operation is described in [Installing Navigator 2 \(page 7-12\)](#).

Power On/Off procedures

This chapter provides the procedures to apply power to and remove power from a Hitachi Adaptable Modular Storage 2100/2300 Storage System. The following topics are discussed:

- ❑ [Task list](#)
- ❑ [Prerequisites](#)
- ❑ [Storage system power on](#)
- ❑ [Storage system power off](#)
- ❑ [Recovering from a power outage](#)

Task list

The process of applying power to the unit includes the following tasks:

- Ensure that all prerequisite tasks have been completed and that the electrical and environmental operating requirements have been met. See below and the specifications listed in the *Hitachi AMS 2000 Family Storage System Reference Guide*.
- If the array includes expansion units or high-density expansion units, ensure that they are connected to the base unit and any other expansion units and that they are plugged in and operating (there are no switches on expansion units).



NOTE: Expansion Unit Power. When the power supplies in the expansion unit are plugged in, the power on self test (POST) starts immediately and takes about 4 minutes to complete. When the test completes successfully, the expansion unit is in standby mode until the main power switch on the base unit is turned on. Power to the ENC unit and the drives is controlled from the base unit via the ENC cable. If only one power supply is plugged in, the fans in the other supply will run at high speed to ensure that the expansion unit has sufficient cooling.

Prerequisites

Verify that the following prerequisites are met before turning on the Main Switch on the AMS 2100/2300 base unit.

- Ensure that all prerequisites and requirements described in [Chapter 5, Installation](#) have been met, and that the site and rack in which the units are installed meet the electrical requirements listed in [Appendix A, Specifications](#).
- Ensure that the circuit breakers or switches in the PDUs are turned on and the PDUs are operational.
- Ensure that both power supplies on the base unit are plugged in and operating. The fans on both power supplies should be running at low speed.

Restarting a base unit

When a base unit is used as the remote unit in a TrueCopy remote replication/TrueCopy Extended Distance configuration, restarting the base unit can cause the following events:

- Both paths of TrueCopy remote replication/TrueCopy Extended Distance are blocked.
- At the time the path is blocked, Navigator 2 sends a failure notice to the users whose email addresses are configured in the Alerts and Events window in Navigator 2. The alert contains information regarding the Email Alert and SNMP Agent Support features and TRAP. Follow the instructions in the email alert. After the remote unit has restarted, the path blockade automatically recovers the paths that are available for use.
- If the pair status of TrueCopy remote replication/TrueCopy Extended Distance is PAIR or COPY, the pair status changes to PSUE.

When the base unit must be restarted, change the pair status of TrueCopy remote replication/TrueCopy Extended Distance to PSUS, and then restart the unit.



NOTE: When the Power Saving storage feature is used, if you restart the base unit while the spin-down is in progress, the spin-down may fail because it recognizes the host immediately after the unit starts.

After the spin-down has completed, check the RAID Groups and make sure that none of them are set to the “Normal (command monitoring)” power saving status. Then restart the unit. If the spin-down fails, start the spin-down again.

Storage system power on

Base unit

The power ON/OFF buttons on the front bezel actuate the Main Switch on the front of the base unit (behind the front bezel). The Main Switch is a rocker switch on the switch panel, which is located in the lower right corner on the front panel of the base unit. See [Figure 6-1](#) and the expanded view in [Figure 6-2](#) on the next page.

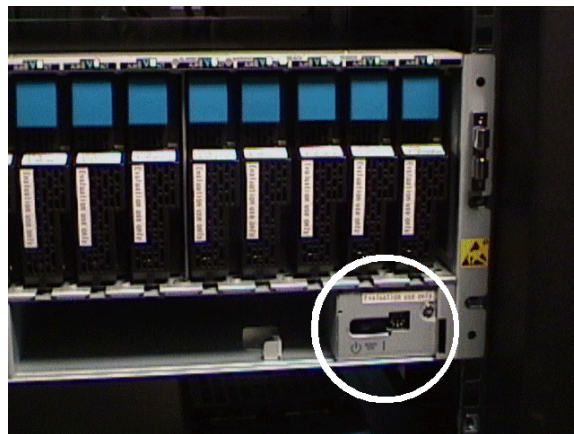

Figure 6-1: Base Unit Switch Panel Location

The Main Switch controls power to all components in the base unit except the power supplies. The power supplies do not have a power switch and turn on as soon as the power cables are connected to them. They can deliver power to the rest of the unit after successful completion of their POSTs.

When only one power supply is plugged in, the multispeed fans on that power supply run at high speed to ensure that the base unit has sufficient cooling. As soon as the second power supply is plugged in, the fans on both power supplies run at low speed to cool the power supplies. When the base unit is running and both power supplies in the base unit are plugged in, the multispeed fans run at whatever speed is needed to provide adequate cooling of all components in the base unit.



NOTE: When the Main switch is toggled to the Standby position, power is still applied to the power supplies. To completely remove the power from the unit, remove both power cables from the unit or disconnect them from the power source.

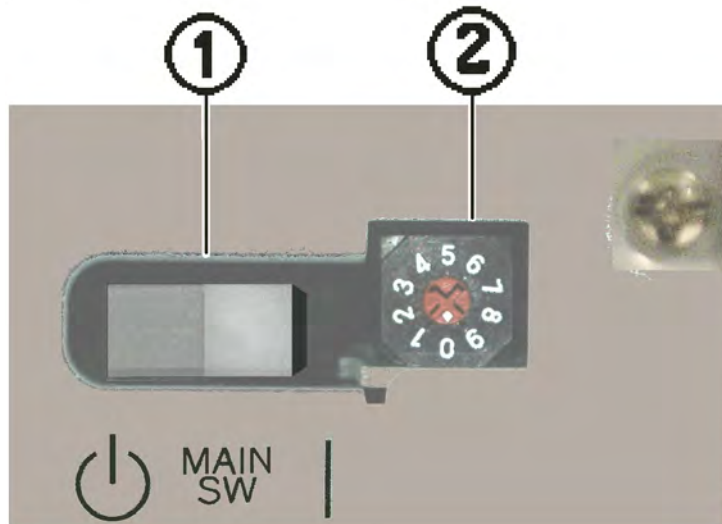





Figure 6-2: Base Unit Switch Panel

Table 6-1: Base Unit Switch Panel

Item	Description	Item	Description
①	<p>Main Switch Applies power to and removes power from the controllers and disk drives in the base unit and the ENC unit and drives in any attached expansion units.</p> <p>The symbol  at the left side of the switch means Standby. (The power supplies remain on)</p> <p>The symbol  at the right side of the switch means ON.</p>	②	<p>Mode Switch Sets the Uninterruptable Power Supply (UPS) mode to either Local Mode or one of three remote modes.¹</p> <p>NOTE: Uninterruptable Power Supplies are not supported by the AMS 2100/2300. Leave this switch in the Local Mode (0) position.</p>

¹Do not change the setting because the normal operation of the subsystem may change.

To apply power to the base unit:

1. Press the right side of the Main Switch. As shown [Figure 6-2](#), the power ON side of the switch is labeled . This applies power to the control units and to the disk drives.
2. Verify that the READY LED (green) on the base unit lights steadily after four minutes. See Power On Self Test below for more information.

Power on self test

When the Main Switch (shown above) is set to ON, each component in the array automatically runs a power on self test (POST). During this time, the array Power LED is on and the Ready light is blinking. The POST takes approximately four minutes under normal circumstances. When the POST is complete and the unit is ready for operation, the Ready light changes from blinking to steady ON.

The base unit automatically runs a POST. The test takes about 4 minutes to complete. If the test completes successfully, the base unit is fully operational and ready for use.

Failures and workarounds

If the base unit does not turn on (the Ready LED stays off) after you turn on the main switch, or when the Ready LED does not stop blinking and light steadily after 4 minutes, see the instructions in [Chapter 8, Troubleshooting](#).



Expansion units and high-density expansion units

Power to expansion units and High-density expansion units is controlled by the base unit via the ENC cable. When you turn the base unit ON or OFF, power to any expansion units connected to that base unit are also turned ON or OFF.

Storage system power off

Base unit

To remove power from the base unit:

1. Turn off the power.
 - With the front bezel installed, press the Power Off button 
 - With the front bezel removed, press the left side of the Main Switch (labeled .

This turns off power to the control units and to the disk drives, but the power supplies will continue to run in standby mode.

2. Verify that the green LEDs above each power receptacle on the rear panel are OFF and that the green Ready LED on the front panel is OFF.

To completely power down a base unit:

1. Turn off the Main / Power switch and verify that the green Ready LED on the front panel is OFF.
2. Turn off the power switches or circuit breakers in the PDBs to which the base unit is connected.
3. Unplug the power cables from **both** power supplies in the base unit.



CAUTION! Residual power may remain in the power supplies for up to a minute after the power supplies are turned off.

Expansion units

Power to the expansion units and high-density expansion units is controlled by the base unit via the ENC cable. When you turn the base unit ON or OFF, power to any expansion units connected to that base unit are also turned ON or OFF. AS with the base unit, the power supplies in the expansion units will remain in standby and the fans will continue to run at low speed.

To completely power down an expansion unit:

1. Turn off the Main / Power switch and verify that the green Ready LED on the front panel of the base unit to which the expansion unit is attached is OFF.
2. Turn off the power switches or circuit breakers in the PDBs to which the expansion unit is connected.
3. Unplug the power cables from **both** power supplies in the expansion unit.



CAUTION! Residual power may remain in the power supplies for up to a minute after the power supplies are turned off.

Recovering from a power outage

If your site experiences a power outage, the backup batteries preserve the contents in cache that have not yet been written to disk. Protection times vary, depending on the size of the cache.



NOTE: The backup batteries do not provide power to the array or act as an uninterruptible power supply.

To restore power to the array after a power outage:



NOTE: If possible, complete the following procedure before the power to the site is restored.

1. Stop all host I/O to the array, if possible.
2. On the base unit front panel, set the Main Switch to standby. 
3. Remove the two power cables from the power receptacles on the array rear panel. To prevent possible damage from a power surge when the power comes back on, leave them disconnected until after the power is restored.

Alternate method: Turn the circuit breakers on the rack PDU off.

4. When power returns, reconnect the power cables to the power receptacles on the array rear panel and then set the Main switch to the ON position. The green Power LED on the front panel should light at this time, and the array performs its POST, which takes about 4 minutes. At that time the green Ready LED on the front panel lights and the unit is ready for use.



NOTE: If the Alarm or Warning LED on the front panel lights instead of the Ready LED, see [Troubleshooting based on LED indications on page 8-13](#)

5. If host I/O activity was stopped, resume I/O activity to the array.

Configuration

This chapter describes how to configure a Hitachi Adaptable Modular Storage 2100/2300 Storage System. Refer to the Host Configuration Guides for information about configuring the host system and for configuring storage on the host system. This chapter contains the following topics:

- ❑ [Configuration tasks](#)
- ❑ [Configuring an AMS 2100/2300](#)
- ❑ [Installing Navigator 2](#)
- ❑ [Managing storage](#)
- ❑ [Using SSL](#)
- ❑ [Setting the day and time](#)
- ❑ [Other storage management operations](#)
- ❑ [Uninstalling Navigator 2](#)

Configuration tasks

This section describes the tasks required to configure an AMS 2100/2300 to store and manage the data from a host system.



NOTE:

- The response performance mode is enabled only when the segment size is 16 kB or less. Be careful when using it with Cache Partition Manager.
 - When changing from the response performance mode to the normal mode, if the I/O load is heavy, you may not change the setting. In this case, perform it after the host I/O stops according to the error message.
 - The processor operation rate becomes high while operating in the response performance mode compared to the rate in the normal mode. When replacing the firmware, it may not be replaced because the processor operation rate is high. If you cannot replace it, we recommend that you replace it again after changing the mode to normal.
 - Encrypt the User Management LAN by Using SSL (Secure Socket Layer).
-

Prerequisites

Before installing the Navigator 2 software and using it to configure the AMS 2100/2300, ensure that the following prerequisites have been met.

User supplied items

In addition to the items supplied with your AMS 2100/2300, the following user-supplied items are required.

For the Hitachi AMS 2100/2300

- If the controllers in the base unit are configured with Fibre Channel interface boards, a Fibre Channel cable for each Fibre Channel data port that will connect to a host.
- If the controllers in the base unit are configured with iSCSI interface boards, a CAT-5 or CAT-6 Ethernet cable for each iSCSI data port that will connect to a host is required.
- A CAT-5 or CAT-6 Ethernet cable to connect the management console to the AMS 2100/2300
- An IP address for each management port

For the management console



TIP: For the best Navigator 2 experience, Hitachi Data Systems recommends that you install Navigator 2 on a new or dedicated PC.

The computer that will be used as the management console must meet the requirements listed in the following table.

Table 7-1: Navigator 2 Operating System Support

Item	Description
Operating System ¹	<ul style="list-style-type: none"> Microsoft Windows 2000 (Service Pack 3 or 4)² Windows XP (Service Pack 2 and 3, 32-bit only²) Windows Server 2003 (Service Pack 1 and 2)² Windows Server 2003 R2 (No SP and SP2) Windows Vista (Service Pack 1) Windows Server 2008 (32 and 64-bit, No SP and Service Pack 2) Windows 7 (No SP, 32 and 64-bit) Windows Server 2008 R2 (No SP, 32-bit)
Browser ³	<ul style="list-style-type: none"> Internet Explorer v6.0, 7.0, 8.0.⁴ Mozilla Firefox v1.7 or higher
CPU	1 GHz Intel processor (2.4 GHz Intel dual-processor recommended)
Memory	1 GB minimum, 2 GB recommended
Free disk space	1.5 GB minimum
Screen resolution	1024×768 or more recommended
Network	Must be connected to the array being managed via LAN

1. Navigator 2 may not run correctly if not running on a supported OS. Note: Navigator 2 does not support 64-bit OS.
2. Navigator 2 does not support 64-bit OS
3. Navigator 2 may not run correctly if not running on a supported browser.
4. Windows 7 or Windows Server 2008 R2 supports only Internet Explorer 8.0.

Supported network standards

The AMS 2100/2300 user LAN port supports the following network standards.

Table 7-2: Supported Network Standards

Item	Standard and Functions	Note
Standard	IEEE 802.3 10BASE-T IEEE 802.3u 100BASE-TX IEEE 802.3 1000BASE-T	
Protocol	ARP, ICMP, ICMPv6, IPv4, IPv6, NDP, TCP, UDP	IPsec support is not scheduled.
Rooting	RIPv1, RIPv2	
RIPng	BGP and OSPF, etc. are unconfirmed.	
IP Address Resolution	DHCPv4 Router Advertisement	DHCPv6 support is not scheduled.
Standard and function not affecting the use of the array	Port VLAN IEEE 802.1Q : Tag VLAN IEEE 802.1D : STP (Spanning Tree Protocol) IEEE 802.1w : Rapid STP (RSTP) IEEE 802.1s : Multiple Instances Spanning Tree Protocol (MISTP) IEEE 802.3ad : Link Aggregation	Note ¹

Table 7-2: Supported Network Standards (Continued)

Item	Standard and Functions	Note
Communication Port	2000/tcp (Non Secure), 28355/tcp (Secure) The array uses the above TCP port for Navigator 2 communication.	Note ² ³

1. The array may not operate depending on the network environment. If it does not operate, consult the network administrator.
2. Cisco Skinny Client Control Protocol (SCCP) uses 2000/tcp. Therefore, when using Navigator 2 in the network environment in which SCCP is introduced, it is required to change the TCP port that Navigator 2 uses. Refer to the Hitachi Storage Navigator Modular 2 (for GUI) User's Guide or Hitachi Storage Navigator Modular 2 Command Line Interface (CLI) User's Guide for the change method. See [Related Documents](#) in the Preface.
3. When obtaining the IPv6 address automatically, the Router Advertisement distribution server is required. If it is not set up, only the link local address (fe80::/10) is allocated as the array address, and communication is limited only in the same link not exceeding the router.

Precautions when using the IPv6 protocol

SNMP agent support function

The SNMP Agent Support function does not support IPv6. When performing failure monitoring, use IPv4 or use the E-mail alert function.

Navigator 2 IPv6 support

Navigator 2 supports IPv6 in the following operating systems, as shown in [Table 7-3](#).

Table 7-3: Navigator 2 IPv6 Support

Vendor	Operating System	Service Pack	IPv6 Support
Microsoft	Windows 2000	SP3/SP4	Not Supported ¹
	Windows XP	SP2	Not Supported ²
	Windows Server 2003 (x86)	SP1/SP2	Supported
	Windows Server 2003 R2 (x86)	SP1	Supported
	Windows Server 2003 R2 (x64)	SP1	Supported
	Windows Vista (x86)	SP1	Supported
	Windows Server 2008 (x86)	SP1/SP2	Supported
	Windows 7 (x86)	No SP	Supported
	Windows 7 (x64)	No SP	Supported
	Windows Server 2008 R2 (x64)	No SP	Supported
	Windows Server 2008 (x64)	SP1/SP2	Supported

1. IPv6 protocol is not supported.
2. Although the IPv6 protocol can be used by installing Microsoft TCP/IP version 6, Navigator 2 does not support it because the Web browser cannot use the IPv6 literal address (address in the colon(:)-delimited hexadecimal form).

IPv6 Link local address

The IPv6 link local address is created automatically from the MAC address regardless of the availability of the IPv6 address. The array creates the interface ID which extends the MAC address (48 bits) to the EUI-64 format (64 bits) and has the address which adds fe80::/10 to the high 64 bits as the link local address.

Example

If the MAC address is "00:00:87:12:34:56"

1. Split the MAC address by 24 bits "000087" and "123456"
2. Insert 1111 1111 1111 1110 (0xFFFE) between the split addresses
0000 87FF FE12 3456
3. Reverse the 7th high bits 0200 87FF FE12 3456
4. Add fe80::/10 to high 64 bits to be the link local address.
fe80::0200:87FF:FE12:3456

Setting the IPv6 address

Hitachi Data Systems recommends that you set the IPv6 address manually. If you obtain the IPv6 address automatically, since the IPv6 address is created based on the MAC address, the IPv6 address set to the array is changed automatically if the control unit is replaced due to a failure, etc. In this case, you would need to register the array again.

For the range of the IPv6 address set manually, use the global unicast address 2001::/16 for the IPv6 Internet.

Incorrect router advertisement

A router advertisement daemon (radvd) is run by Linux or BSD systems acting as IPv6 routers. It sends Router Advertisement messages, specified by RFC 2461, to a local Ethernet LAN periodically and when requested by a node sending a Router Solicitation message. These messages are required for IPv6 stateless autoconfiguration.

When changing the contents of the distributed Router Advertisement, perform the Router Advertisement (set router lifetime indicating the expiration date to 0) to disable the previous Router Advertisement from the Router Advertisement distribution server side. If the Router Advertisement distribution server side does not disable it, the new Router Advertisement is received by changing the IPv6 address of the array to the fixed setting once and changing it to the automatic setting again. When this operation is completed, since the IPv6 Advertisement of the array is changed, you must register the array and system again.

Temporary address

The temporary address specified by RFC3041 is enabled for Windows Vista. When connected by IPv6, many temporary addresses may be registered in the installed PC and the processing time may become long depending on your system environment. Check the temporary addresses, and if many are set, disable them.

You can display the status of the temporary address by entering the following command from the command prompt.

```
C:\> netsh interface ipv6 show privacy
```

Enter the following command to disable the temporary address:

```
C:\> netsh interface ipv6 set privacy disable
```

Enter the following command to enable the temporary address:

```
c:\> netsh interface ipv6 set privacy enable
```

Connection method

The following illustration shows an example of a connection between the AMS 2100/2300 and the computer in which Navigator 2 is installed on the host computer and not a separate management console.

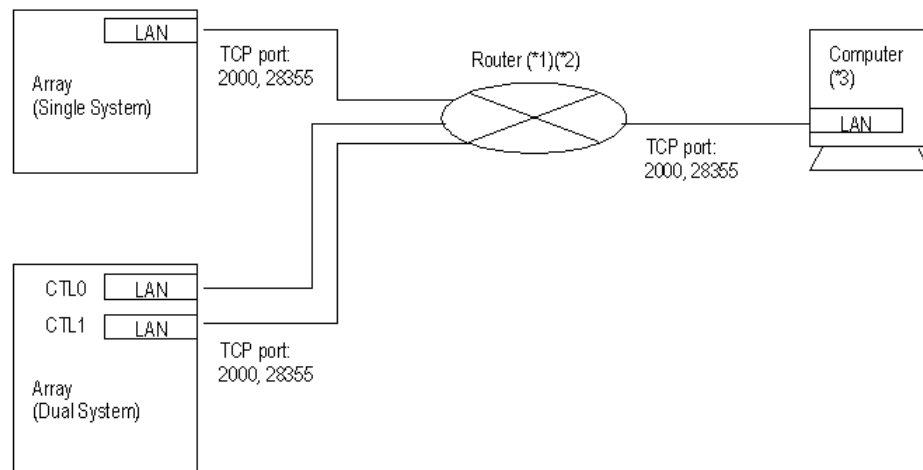

The following are notes regarding the above illustration:

1. The array uses 2000/tcp and 28355/tcp to communicate with Hitachi Storage Navigator Modular 2. When it can be connected directly but cannot communicate through the router, the router may have blocked ports. Set the router so that the two-way communication to ports is allowed.
2. The IPv6 multicast of the link local scope is used for the search array by the IPv6 address. When performing the search array, set up the array and the computer in which Hitachi Storage Navigator Modular 2 is installed in the same link.
3. When two or more LAN cards are inserted in the computer to install Hitachi Storage Navigator Modular 2 and each LAN is another segment, it can only access from the LAN card side specified by the installer.

The following illustration shows another example of a connection between the AMS 2100/2300 and the computer in which Navigator 2 is installed on a separate management console.

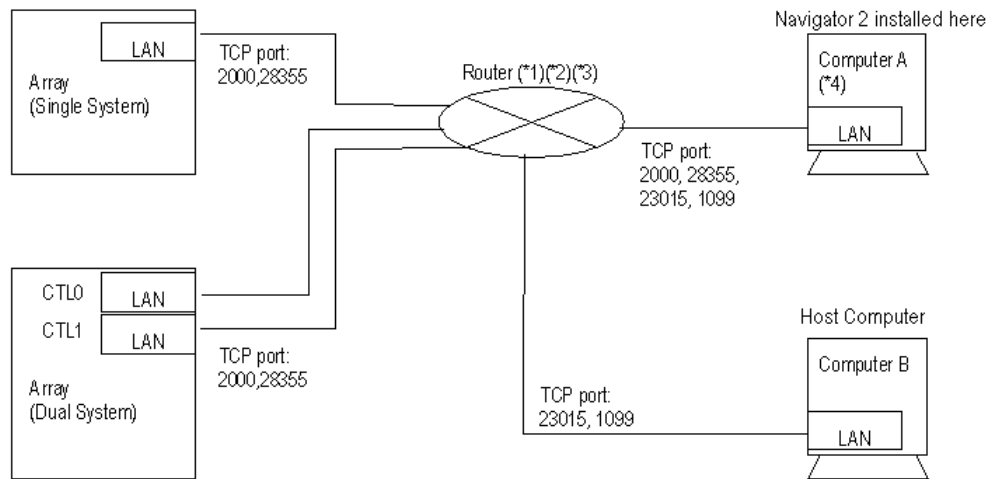

The following are notes regarding the above illustration:

1. The array uses 2000/tcp and 28355/tcp to communicate with Navigator 2.
2. If the array can communicate with the computer on which Navigator 2 is installed directly but not through the router, the router may have blocked ports. Set the router so that two-way communication to ports is allowed.
2. The computer in which Navigator 2 is installed (Computer A) uses 23015/tcp and 1099/tcp to communicate with the computer to the host (Computer B). When the computer on which Navigator 2 is installed can communicate if connected directly but cannot communicate through the router, the router may have blocked ports. Set the router so that the two-way communication to ports is allowed.
3. The IPv6 multicast of the link local scope is used for the search array by the IPv6 address. When performing the search array, set up the array and the computer in which Hitachi Storage Navigator Modular 2 is installed in the same link.
4. When two or more LAN cards are inserted in the computer to install Navigator 2 and each LAN is another segment, it can only access from the LAN card side specified by the installer.

Communication modes

When the communication settings between the array and the host and/or management console are not the same, they may not be able to communicate with each other. The communication mode for the array is set to “**Auto**” by default. Therefore, Hitachi Data Systems recommends that you set the host and any other storage devices on the LAN to **Auto**.

Table 7-4 shows the combination of settings for the array and the host and the settings that work.

Table 7-4: Communication Settings

	Auto	10 Mbps Half	10 Mbps Full	100 Mbps Half	100 Mbps Full	1000 Mbps Full
Auto (Default)	○	X	X	X	X	X
10 Mbps Half	X	○	X	X	X	X
10 Mbps Full	X	X	○	X	X	X
100 Mbps Half	X	X	X	○	X	X
100 Mbps Full	X	X	X	X	○	X
1000 Mbps Full	X	X	X	X	X	○
○ : Communication possible			X : Communication not possible			

Configuring an AMS 2100/2300

This section explains how to set up and configure an AMS 2100/2300.

Prerequisites

Before using Navigator 2, please read the following notes and instructions.

- If you are using Microsoft Windows, disable Windows power management to prevent the PC from entering the low power mode suspension state.
- When connecting the array with Navigator 2 via a LAN, depending on the LAN environment, the array could be disconnected if there is a data transfer time-out. When Navigator 2 cannot connect with the array, verify the connection by pinging the array from the management console. If ping command returns an IP address and does not time out, the LAN environment may be negatively affecting the data transfer. The length of data to be transferred can be changed with the lanconf.inf file in the directory in which Navigator 2 is installed. The default setting is 32768. Change the setting to 16384 or 8192 in that order, or to a multiple of 1024, and then retry. The new setting becomes effective during the next operation (restarting Navigator 2 is not required). Navigator 2 operations may be very slow, depending on the setting. If the connection cannot be made after the settings are changed, review the LAN environment.
- Do not use the reserved words discrete for each OS or device names that indicate the input/output destinations as a file name when a file is output. Windows includes "con", "pm", "ax", etc. and UNIX® includes "/"def*", etc. For example, when context is specified as an output file name, an error message is displayed in a window.
- If you connect Navigator 2 to an array via a LAN, set the TCP/IP port number to 1099. If you cannot connect, verify the TCP/IP port number.

Configuration roadmap

Table 7-5 lists the basic steps to configure an AMS 2100/2300.

Table 7-5: Task List

Step	Task (Click the link to display detailed information)
1 ¹	Install the storage management software (See page 7-12)
2	Change the storage management PC IP address (See page 7-12)
3	Power On the storage system (See Chapter 6, Power On/Off procedures)
4	Add an array to Navigator 2 (See page 7-18)
5	Perform the Initial Setup (See page 7-22)
6	Restore the storage management console (page 7-28)
7	Reregister the array (See page 7-29)
8	Set up the host ports (See page 7-26)

1. If the storage management software has already been installed, this step is not required.

Introducing Navigator 2

Hitachi Navigator Modular 2 Navigator 2 (referred to as Navigator 2) is the storage management software application that is used to set up and configure a variety of Hitachi Data Systems storage products, including the AMS 2100/2300. It consists of a GUI and underlying software that is used to accomplish many storage management configuration tasks.

Navigator 2 includes a set of easy-to-use wizards that are used for the initial setup of the array and that automate complex and/or repetitive tasks. They can help users quickly and easily configure, provision, and manage both simple and complex setups. Navigator 2 also includes comprehensive set of utility functions (features) that are used to configure and manage the storage functions on the array. Although you can manage several models of Hitachi Data Systems storage arrays, this manual provides instructions for only the AMS 2000 series models.



NOTE: Navigator 2 does not support the window change function of a browser. The following procedures are for Internet Explorer to return to the previously displayed browser window. When the installation starts, follow the instructions in the screens that appear. During the installation, you will be asked to either accept the default destination directory where Navigator 2 will be installed or specify a different location.

- Press the Back Space key.
- Press the ← key while holding down the Alt key.
- Right click in the window and select "Back" in the drop down menu that is displayed.

If you perform any of the above on the displayed window by clicking Create or Edit with Navigator 2, the message "Now loading" is displayed and it may not close. In this case, Press the ✕ (Close) button at the top right of the window to close it, and open it again.

Navigator 2 features

Table 7-6 describes the main features of Navigator 2.

Table 7-6: Navigator 2 Features

Category	Function Name	Description	System Usable During Operation?
Configuration display	Component status display	Displays the status of a component such as drive and fan.	Yes
	Property display	Displays the status about system components of an array unit, RAID, logical units, etc.	Yes
Manage Logical Units	Create Logical Units	Used to add a logical unit. A new logical unit is added by specifying its capacity.	Yes
	Delete Logical Units	Deletes the defined logical unit. User data is deleted.	No
	Format Logical Units	Required to make a defined logical unit (LU) accessible by the host. Writes null data to the specified logical unit, and deletes user data.	No /Yes
Setting the Selection	Command Device	Sets up the command devices. This is only used for replication purposes.	
Configuration	Setting the Boot Option	Sets up the boot option. The array must be restarted to implement the setting	No
	Setup and Display iSCSI Information	Sets and displays IP addresses and security information, etc.	No
	System Parameters	Sets up the system parameters.	Yes
	Port option	Configures the options on each port used by the array	Yes
	Setup and Display of RTC	Sets and displays the date and time.	Yes
Upgrades	Firmware Upgrades	Downloads and updates the array microcode. You must reboot the array to implement the settings.	No /Yes
Error Monitoring	Report when a failure occurs and controller status display	Polls the array and displays the status. If an error is detected, it is output into a log file and sent by email. A specified application is started.	Yes

Storage features

Table 7-7 lists the software that is already installed on the array and is ready for use, as well as software that is installed but must be enabled with a license key. Contact HDS Technical Support to obtain licenses for the optional software.

Table 7-7: Storage Features

Storage Feature	Type	Default State at startup	License Key Required
Installed Storage Features – Licensed and Ready to Use			
Firmware & Storage Feature Kit	Common License Key "A"		No
Base Firmware	Included	N/A	No
Audit Logging	Included	Enabled	No
Account Authentication	Included	Enabled	No
LUN Manager	Included	Enabled	No
Cache Residency Manager	Included	Disabled	No
Cache Partition Manager	Included	Disabled	No
Modular Volume Migration	Included	Disabled	No
SNMP Agent Support	Included	Enabled	No
Performance Monitor	Included	Enabled	No
Optional Storage Features			
Power Saving	Download	N/A	Yes
Data Retention Utility	Download	N/A	Yes
In-System Replication Suite	Download	N/A	Yes
ShadowImage	Download	N/A	Yes
Copy-on-write Snapshot	Download	N/A	Yes
TrueCopy Remote Replication	Download	N/A	Yes
TrueCopy Extended Distance	Download	N/A	Yes



NOTE: For detailed information and instructions for using Navigator 2 to manage a variety of Hitachi Data Systems storage array models, see the Navigator 2 Online Help and the manuals listed in the [Accessing product documentation](#) section in the Preface of this manual. In the Hitachi Data Systems main menu, click **Help > Help** to launch the online help, OR click the help button in and Navigator 2 window or dialog box.

Installing Navigator 2

This section describes the procedure to install the Navigator 2 software.

Changing the storage management PC IP address

To connect the array and the storage management PC to a network, the storage management PC IP address must be changed temporarily.



NOTE:

- This procedure is not necessary if you are connecting the array with IPv6 from the storage management PC.
 - If you are connecting the management PC to the array with IPv4 or other cable, perform this procedure.
-

Complete the following steps to change the Storage Management PC IP address:

1. Connect the 10/100 Ethernet Management Port on the array (controller #0) and the storage management PC with a CAT-5 Ethernet cable.
2. Open a command (DOS) window and use the command **ipconfig** to find out the IP address of the management console.
3. Record this address as you will need to reset the management console back to that address later.
4. The default IP addresses of the management ports on the AMS 2100/2300 are:
 - Controller 0: 192.168.0.16
 - Controller 1: 192.168.0.17
5. If the IP address of the management console does not match the default subunit of the management ports, configure the management console to use an IP address that matches the default subnet (192.168.0.x) of the management port.

Navigator 2 Installation procedure

This section explains how to install the Navigator 2 storage management software. Instructions to uninstall the software are located at the end of this chapter.



NOTE: IMPORTANT. Before installing Navigator 2, disable pop-up blockers in your Web browser. Hitachi Data Systems also recommends that you disable anti-virus software and proxy settings on the management console before installing Navigator 2.

Complete the following steps to install the Navigator 2 storage management software. The installation process takes about 15 minutes.



NOTE: During the installation, the progress indicator that is displayed may pause a few times for several seconds to a minute depending on the speed of the computer and any other processes that are running during the installation. This happens while the installer is unpacking and installing the files and is normal. Do not cancel the installation during this time.

To install Navigator 2:

1. Insert the CD containing the Navigator 2 software into the CD-ROM drive on management console.
2. If the autorun program does not start, use Windows Explorer to browse the CD, and double click the file.

`\program\hsm2_win\HSNM2-nnnn-W-GUI.exe`.

where nnnn is the Navigator 2 version number.

3. When the installation starts, follow the instructions in the installation wizard. During the installation, you will be asked to:
 - Accept the default destination directory where Navigator 2 will be installed or specify a different location.version number.
 - Enter the IP address of the management system during the installation.

Installing Java

The Advanced Settings options in Navigator 2 are implemented through the Storage Navigator Modular management application that is used to manage the storage features in earlier versions of the Adaptable Modular Storage hardware.

To use this feature, you must have the proper Sun Java Runtime Environment (JRE) loaded and the Java Console set properly on your system. The requirements are as follows:

- JRE version v1.6.0.
- From the Java Console on your PC, set the Java Runtime parameters to the following: `-Xmx192m`



NOTE: Before accessing Advanced Settings, enter the following memory setting in the Java Console on the browser PC: `-Xmx192m`. Otherwise, Advanced Settings will fail, and you will be locked out and unable to access Advanced Settings until the login times out (20 minutes).

Clients running Microsoft Windows

If your client runs Microsoft Windows, perform the following procedure:

1. Select **Start > Settings > Control Panel**. The Windows Control Panel appears.
2. From the Windows Control Panel, double-click **Java Control Panel**. The Java Control Panel appears.
3. Click the **Java** tab. The Java tab is displayed as shown in [Figure 7-1](#).

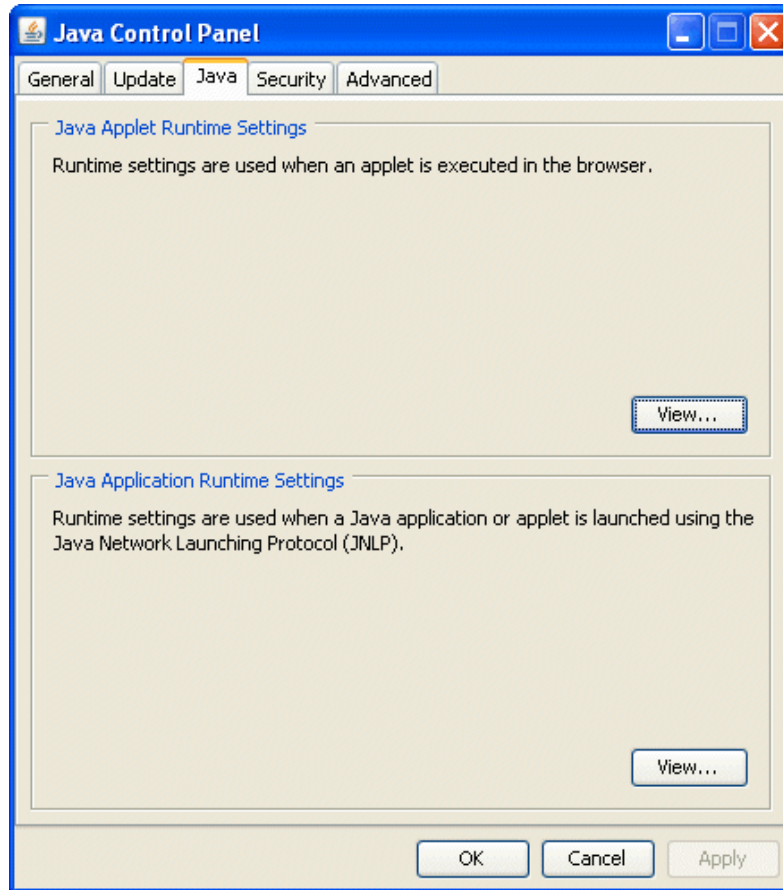

Figure 7-1: Java Tab

4. In the Java Applet Runtime Settings section, click **View**. The Java Runtime Settings dialog box appears.
5. In the Java Runtime Parameters field, enter **-Xmx192m**.

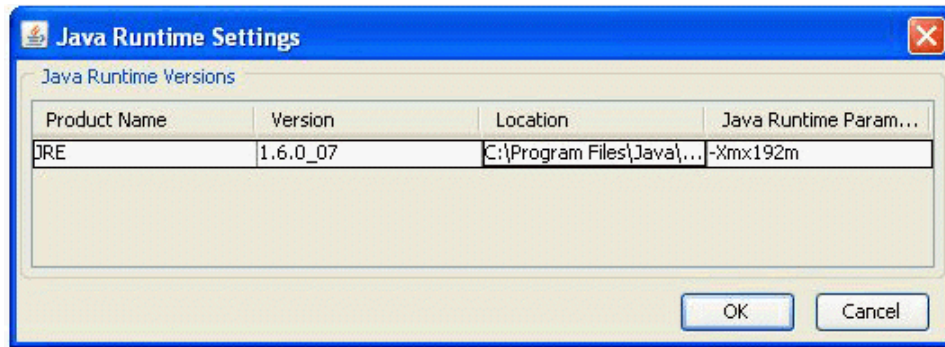

Figure 7-2: Java Runtime Settings Dialog Box

6. Click **OK** to exit the Java Runtime Settings dialog box.
7. Click **OK** in the Java tab to close the Java Control Panel dialog box.
8. Close the Windows Control Panel.

Clients running Solaris or Linux

If your client runs Solaris or Linux, perform the following procedure:

1. From an XWindows terminal, enter **<JRE installed directory>/ bin/ jcontrol** to run the Java Control Panel.
2. In the Java Applet Runtime Settings section, click **View**. The Java Runtime Settings dialog box appears.
3. In the Java Runtime Parameters field, enter **-Xmx192m**.
4. Click **OK** to exit the Java Runtime Settings dialog box.
5. Click **OK** in the Java tab to close the Java Control Panel dialog box.

Installation problems

If you have problems with the installation or if Navigator 2 does not install correctly, or does not run after it is installed, please contact Hitachi Data Systems Technical Support. See [Support Contact Information](#) in the Preface for contact information.

Starting Navigator 2

1. After the software is installed, launch a Web browser on the management console.
2. Enter the appropriate URL in the address field.
 - If you are using http, enter the following URL in the address field:
http://<IP address>:23015/StorageNavigatorModular/Login
where <IP address> is the IPv4 or IPv6 address of the management console.
 - <If you are using http, enter the following URL in the address field:
https://<IP address>:23016/StorageNavigatorModular/Login
where <IP address> is the IPv4 or IPv6 address of the management console.



NOTE: The https URL is invalid immediately after the installation. Refer to [Using SSL on page 7-43](#).

When you enter an IPv6 address, you must enclose the URL in brackets []
Example: http://[xxxx]:23015/StorageNavigatorModular

After a few seconds, the welcome screen is displayed, as shown here.

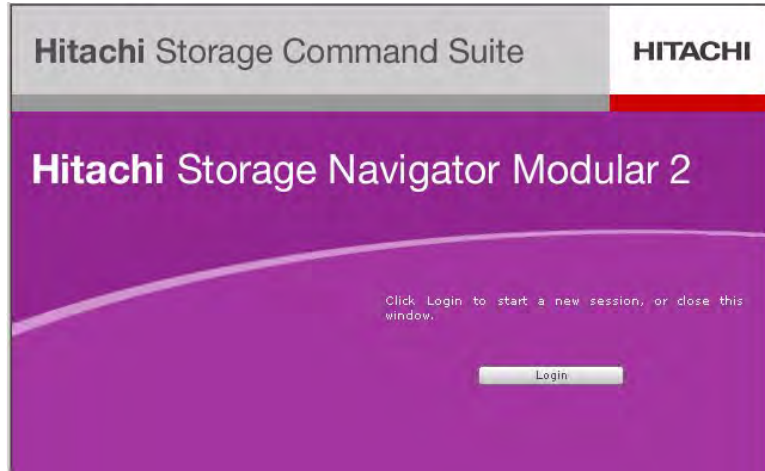

3. Click **Login** to display the login screen shown in the next illustration.

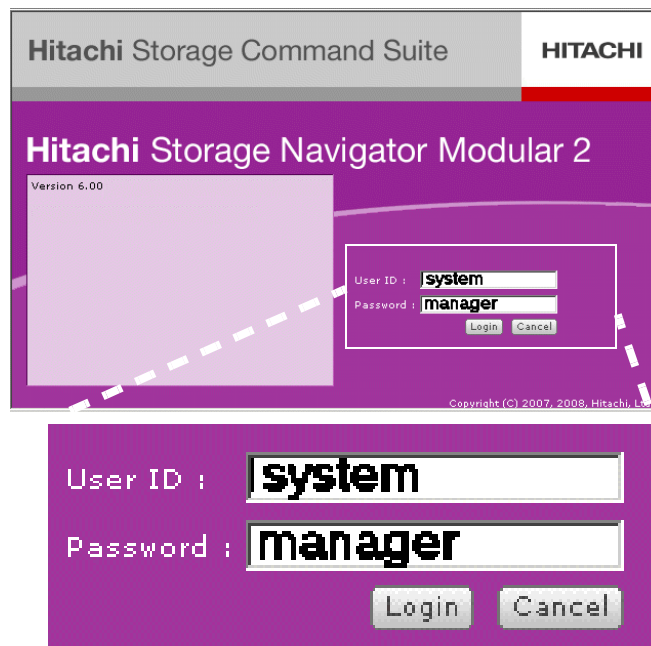

4. Enter the default administrator user ID and password as shown in the above illustration.

5. Press **Enter** or click **Login**. After several seconds Navigator 2 displays the Array List Window, as shown in the following illustration.

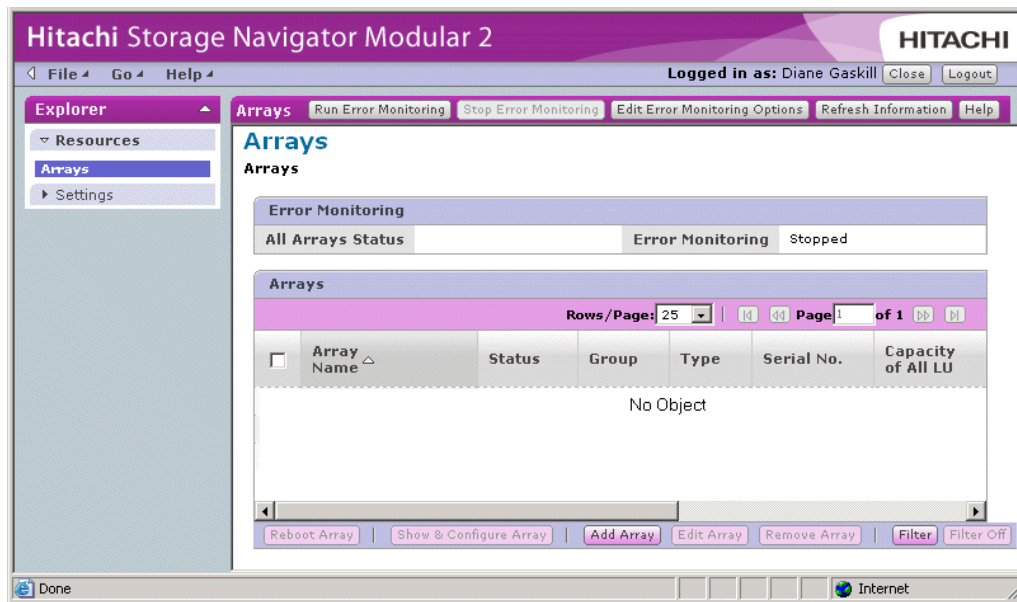

NOTE: For security reasons, Hitachi Data Systems recommends that you change the password after logging in. The Navigator 2 online help contains a detailed procedure explaining how to do this. In Navigator 2, locate the main Help button and click **Help > Help** to launch the online help. In the Contents pane, select **Managing User Accounts > Change Your User Password**. Follow the instructions in this help page.

Managing storage

This section briefly explains how to use Navigator 2 to manage storage on a network. It contains the following topics:

- [First time storage configuration - required tasks](#)
- [Additional storage configuration - optional tasks](#)
- [Managing resources](#)
- [Managing replication](#)
- [Backing up your data](#)

First time storage configuration - required tasks

Setting up storage on an AMS 2100/2300 array is actually very easy. Navigator 2 includes a set of wizards that guide you through the two initial tasks to add arrays and set them up. In addition, a set of simple dialog boxes is included to guide you through the procedure to map the storage on the array to a host so that the host can manage the storage assigned to it. These procedures are explained below.

Adding arrays to Navigator 2

Whenever Navigator 2 is launched, after you log in, Navigator 2 loads into memory (this may take several seconds). It then automatically searches the Navigator 2 database for any arrays listed there, and then displays the Arrays window (also called the Array List Window).

If there are arrays listed in the database, Navigator 2 displays them in the Array List window. If there are no arrays listed in the database, Navigator 2 automatically launches the **Add Array wizard**. Therefore, when Navigator 2 is first installed and launched, it automatically launches the Add Array wizard.



NOTE: If the wizard does not launch, ensure that your browser's pop-up blockers are disabled. Then click **Add Array** at the bottom of the Array List window to launch the Add Array wizard.

Using the Add Array Wizard

The Add Array wizard guides you through the steps to discover existing arrays (within a range of IP addresses you set) on the storage network, and add the arrays you select from the list of arrays to the Navigator 2 database. It contains four screens, as described below. Click the links to see the detailed explanation of each page in the wizard.

[Introduction screen](#) > [Search array screen](#) > [Add array screen](#) > [Finish screen](#)

Introduction screen

This screen explains the purpose of the wizard and sets up the criteria that is used when searching a storage network for arrays. Click **Next** to continue and open the Search Array screen.

Search array screen

This screen sets the criteria that is used when searching a storage network for arrays.

The screenshot shows the 'HSNM2 - Add Array Wizard' interface with the 'HITACHI' logo in the top right. The progress bar indicates the current step is '2. Search Array'. Below the progress bar, it says 'Enter the information for array searching.' The main form area is titled '* Search Method:' and contains two radio button options: 'Specific IP Address or Array Name:' (which is selected) and 'Range of IP Addresses:'. The 'Specific IP Address or Array Name:' option has two input fields for 'Controller 0:' and 'Controller 1:'. Below these fields is the instruction 'Enter the IP Address or array name. Array name can't be more than 255 characters.' The 'Range of IP Addresses:' option has a checked checkbox for 'Range of IPv4 Address:' and an input field for 'From:' and 'To:' with IP address format boxes. There is also a checked checkbox for 'Search IPv6 Address automatically'. Below the search method options is the '* Using Ports:' section with three radio button options: 'Non-secure Port' (selected), 'Secure Port', and 'Non-secure and Secure Ports(Secure port is searched at first.)'. At the bottom left of the form area, there is a note '* Required field'.

Select one of the following choices:

- Adding a Specific Array (see below to add multiple arrays)
 - a. If you know the IP address of a specific array that you want to add, click **Specific IP address or Array Name:** and enter either the IP address of the array or the array name. Click **Next** to continue and open the Add Array screen.
- Adding Arrays Within a Range of IP addresses
 - a. If you know the range of IP addresses that includes one or more arrays that you want to add, click **Range of IP addresses to Search** and enter the low and high IP addresses of that range. The range of addresses must be located on a connected local area network (LAN).
 - b. Click **Next** to continue and open the Add Array screen.



NOTE: if any of the IP addresses you entered is incorrect, when you click Next, Navigator 2 displays the following message:
Failed to connect with the array. Confirm the array status and the LAN environment, and then try again.

Add array screen

This screen displays the results of the search that was specified in the Search Array screen. Use this screen to select the arrays you want to add to Navigator 2.

HSNM2 - Add Array Wizard HITACHI

1. Introduction ▶ 2. Search Array ▶ **3. Add Array** ▶ 4. Finish

All the detected arrays are added to the navigator. If you don't want to add some arrays, turn off the check-mark on the list.

* The arrays that is added to the navigator:

<input type="checkbox"/>	Array Name △	Type	Controller 0	Controller 1	Serial No.
<input checked="" type="checkbox"/>	DF800M_85010020	DF800M	172.17.44.60	172.17.44.61	85010020
<input type="checkbox"/>	DF800M_85010065	DF800M	172.17.44.72	172.17.44.73	85010065
<input checked="" type="checkbox"/>	DF800M_85010068	DF800M	172.17.44.70	172.17.44.71	85010068
<input type="checkbox"/>	DF800M_85010128	DF800M	172.17.44.78	172.17.44.79	85010128
<input checked="" type="checkbox"/>	DF800S_83010125	DF800S	172.17.44.80	N/A	83010125

* Required field

< Back Next > Cancel Help

1. If you entered a specific IP address in the Search Array screen, that array is automatically registered in Navigator. Click **Next** to continue to the Finish screen. A message box confirming that the array has been added is displayed.
2. If you entered a range of IP addresses in the Search Array screen, all of the arrays within that range are displayed in this screen, as shown in the next illustration.
3. When the list of arrays is displayed, all the arrays in the list are automatically selected. Click the checkbox to the left of the array name to deselect the array.
4. Click **Next** to add the selected arrays to the Navigator 2 database and continue to the Finish screen.

Finish screen

This screen displays a message confirming that the arrays have been added to Navigator 2. Click **Finish** to acknowledge the message and close the Add Array wizard.

Navigator 2 refreshes the Array List window and displays the arrays that you added.

Managing a specific array

You can work with only one array at a time. To select an array to manage:

1. In the Array List window, click the name of the array that you want to configure. Navigator 2 queries the array, extracts data about the array, and stores it in memory. This may take a few seconds. When the Array Properties window opens, Navigator 2 displays the information about the selected array that is stored in memory.

Array security

AMS 2100/2300 arrays are configured with a security protocol called Account Authentication (AA). When you select an array, Navigator 2 displays the AA login screen as shown below. You must log in to the array before Navigator 2 will display the Array Properties window.

2. **First time login:** Enter the default AA username (**root**) and password (**storage**) as shown in the following illustration. Note that this is a different username and password than is used to log in to Navigator 2.

HSNM2 - Add Array Wizard HITACHI

Log in -DF800M_85010213

Log in

Enter the information to log in the array.

* User ID:

* Password:

* Required field

Login Cancel

* User ID:

* Password:

* Required field

3. Click **Login**. If the username and password are valid, Navigator 2 displays the Array Properties window for the selected array as shown in the following illustration.



CAUTION! If you change the AA password, be sure to write the new password down and keep it in a safe place. Without a valid password, you cannot access the array without reinstalling the firmware. Hitachi Data Systems Technical Support cannot retrieve the password for you. Note that the user ID is not changeable.

For more information, see the Account Authentication chapter in the *Hitachi Navigator 2 Storage Features Reference Guide for AMS*.

The screenshot shows the management console for an array named 'DF800M_85010027'. The left sidebar contains a tree view with 'Alerts & Events' selected. The main area displays a 'Summary' table and a 'Common Array Tasks' section. The 'Initial Setup' task is circled in orange.

Summary			
Status	Warning	Capacity of All LU	541.2GB
Type	DF800M	Raw Capacity of All Drives	1.9TB
Serial No.	85010027	IP Address	Controller 0 172.17.44.76
Array ID	85010027	Controller 1	172.17.44.77
Firmware	0832/G-M		

Common Array Tasks
Following menu will help you for typical tasks. For further settings, please use the tree menu.

- Initial Setup**: Configure several items on the array to make it ready to use.
- Install License**: Install Licenses of optional functions (Program Products).
- Create Logical Unit and Mapping**: Create logical unit and mapping easily.
- Update Firmware**: Update the control program in the array from local file or support website.
- Backup Volume**: Copy the selected volume to prevent data loss.
- Check for Errors**: View the Alerts & Events screen and show the latest status of the array.
- Look at All Arrays**: Log out this array and go back to the list of arrays. Then choose another array to manage.

Initial array setup

This section describes the procedure to configure the basic settings of an array. The Array Setup wizard is used to do this.



NOTE: Hitachi Data Systems recommends that you set the IP address manually. If you set the IP address to be obtained automatically in IPv6, the IPv6 address is decided by the Ethernet address. Therefore, if the Control Unit is replaced due to a failure, etc., the IP address will be changed. To change the time or synchronize with a Network Protocol Time (NTP) server, use the procedure under [Setting the day and time on page 7-52](#).

1. Click **Initial Setup**. After a few seconds, the **Array Setup wizard** launches. This wizard guides you through the following tasks. Each task listed here is a link to the detailed explanation that follows,

[Introduction](#) > [Set up email alert](#) > [Set up management ports](#) > [Set up host ports](#) > [Set up spare drives](#) > [Set up date and time](#) > [Confirm](#) > [Finish](#)

Introduction

The introduction page lists the tasks that can be completed by this wizard. Click **Next** > to continue to the next screen and begin the setup process.



NOTE: Important! The settings you make on the screens in this wizard are not saved until you complete the wizard settings and select Confirm on the last Confirm screen in this wizard.

Set up email alert

The screenshot shows the 'HSNM2 - Setup Array Wizard' interface. At the top, there is a progress bar with steps: 1. Introduction, 2. Set up E-mail Alert (current step), 3. Set up Management Ports, 4. Set up Host Ports, 5. Set up Spare Drive, 6. Set up Date & Time, 7. Confirm, and 8. Finish. Below the progress bar, there is a heading '8. Finish' and a sub-heading 'Select Disable or Enable for E-mail Error Report. When enabling, enter the required information in the text boxes.' A note states: 'If error is occurred in the array, the array itself will send E-mail to report the error to Send To Address(es) automatically.'

The main form area is titled '* E-mail Error Report:' and contains two radio buttons: 'Disable' (unselected) and 'Enable' (selected). Below the radio buttons is a large rectangular box containing several input fields:

- Domain Name: [Text input field]
- Mail Server Address: [Text input field]
- From Address: [Text input field]
- Send To Address: (1) [Dropdown menu with 'To' selected] [Text input field]
- (2) [Dropdown menu with 'To' selected] [Text input field]
- (3) [Dropdown menu with 'To' selected] [Text input field]
- Reply To Address: [Text input field]

At the bottom left of the form box, there is a small asterisk and the text '* Required field'.

This dialog box sets up Navigator 2 so that if an error occurs in the array, it will send an email report describing the error to as many as three email addresses that are entered here. Follow these steps to set up email notification:

1. Click **Enable**. The fields in this dialog box are now enabled and you can enter data in them.
2. Enter the domain name of the mail server. Example: hds.com.
3. Enter the IP address of the email server that will route the email messages to the email addresses listed in this dialog box.
4. Enter a From email address. This email address will appear on the distributed email messages. This enables the users who receive the reports to quickly identify the array from which the messages came.
5. Enter up to three email addresses of people to whom the alerts will be sent.
6. (Optional) Enter a Reply To email address.
7. Click **Next**> to exit this screen and open the Set up Management Ports screen.

Set up management ports

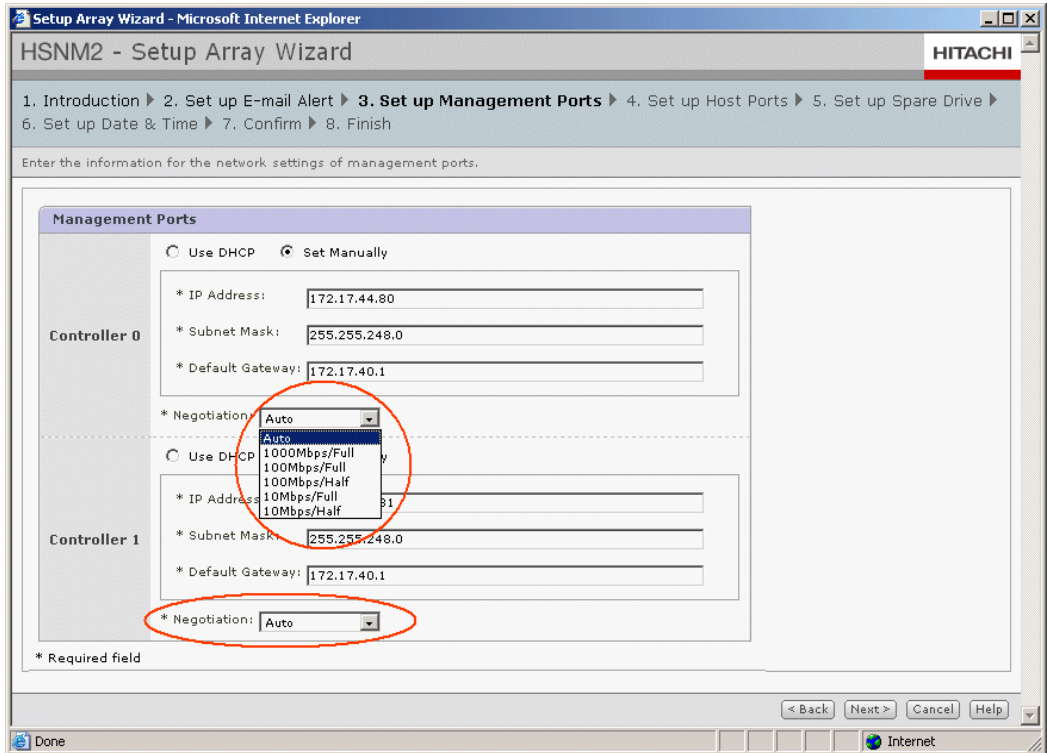

The management ports allow direct access to the controllers in the array. When this screen is displayed, Navigator 2 checks the array and fills in the default values for the selected array. You can use these settings successfully, but you can also change the values if needed.

Table 7-8: Configuring Management Ports

Field	Description
Use DHCP	Configures the management port automatically, but requires a DHCP server. To let the system find and use any available IP address for the management port(s), click Use DHCP (Dynamic Host Configuration Protocol) on the controller(s) that you want to use that way.
Set Manually	Lets you complete the remaining fields to configure the management port manually. To use the default IP addresses, select Set Manually for the controller(s) that you want to use with a static IP address. To use other static IP addresses, select Set Manually for the controller(s) that you want to use with a static IP address and enter appropriate information in the IP address , Subnet Mask , and Default Gateway fields. See the following descriptions.
IP address	Internet Protocol address that client PCs use to access the base unit's management port.
Subnet Mask	Subnet mask that client PCs use to access the base unit's management port.
Default Gateway	Default gateway that client PCs use to access the base unit's management port.

Table 7-8: Configuring Management Ports

Field	Description
Negotiation	As shown in the above illustration, to use the default negotiation between the controller and the host, leave the Auto setting as is. Otherwise select the speed and duplex mode that the controller will use to communicate with the host. The options are: <ul style="list-style-type: none">• 1000 Mbps, Full Duplex• 100 Mbps, Full Duplex• 100 Mbps, Half Duplex• 10 Mbps, Full Duplex• 10 Mbps, Full Duplex

If you know what the communication setting of the host is, you can optionally set the negotiation speed and mode of the management port(s) to match. If you do not know the communication setting on the host, leave the setting at **Auto** and let the controller query the host and set the port to the appropriate speed and duplex mode.

When you have completed the settings, click **Next>** to continue to the next screen. Note that the settings you have made are not saved until you complete the wizard settings and select **Confirm** on the last screen of the wizard.



NOTE:

- If the management console is directly connected to a management port on one controller, enter settings only for that controller (you will configure the management port settings for the other controller later).
- If the management console is connected via a switch or hub, you can enter settings for both management controllers now.

Set up host ports

HSNM2 - Setup Array Wizard HITACHI

1. Introduction ▶ 2. Set up E-mail Alert ▶ 3. Set up Management Ports ▶ **4. Set up Host Ports** ▶
5. Set up Spare Drive ▶ 6. Set up Date & Time ▶ 7. Confirm ▶ 8. Finish

Enter the information for the host ports.

FC Ports	
Port0A	* Port Address: 0000EF * Transfer Rate: Auto * Topology: Loop
Port0B	* Port Address: 0000EF * Transfer Rate: Auto * Topology: Loop

FC Ports	
Port1A	* Port Address: 0000EF * Transfer Rate: Auto * Topology: Loop
Port1B	* Port Address: 0000EF * Transfer Rate: Auto * Topology: Loop

* Required field

< Back Next > Cancel Help

As with the management ports, Navigator 2 queries the host ports on the array and lists their current settings in the Setup Host Ports dialog box as shown above.

1. To use the default settings, click **Next>** to continue to the Set Up Spare Drive screen.
2. To change the settings, use the pull-down menus for the Transfer Rate and/or Topology fields for each ports as needed to match the settings on the host ports. Then click **Next>** to continue to the Set Up Spare Drive screen.

Set up spare drives

HSNM2 - Setup Array Wizard HITACHI

1. Introduction ▶ 2. Set up E-mail Alert ▶ 3. Set up Management Ports ▶ 4. Set up Host Ports ▶
5. Set up Spare Drive ▶ 6. Set up Date & Time ▶ 7. Confirm ▶ 8. Finish

Select spare drive in available drives. Instead of a broken drive of RAID group, a spare drive use to keep RAID level. It is necessary to same drive type (SAS or SATA) and more capacity of a broken drive.

Spare Drive:

<input type="checkbox"/>	Tray ▲	Drive	Drive Type	Drive Capacity
<input checked="" type="checkbox"/>	00	10	SAS	300GB
<input checked="" type="checkbox"/>	00	11	SAS	300GB
<input type="checkbox"/>	00	12	SAS	300GB
<input type="checkbox"/>	00	13	SAS	300GB
<input type="checkbox"/>	00	14	SAS	300GB
<input type="checkbox"/>	01	00	SATA	1TB
<input type="checkbox"/>	01	01	SATA	1TB
<input type="checkbox"/>	01	02	SATA	1TB
<input type="checkbox"/>	01	03	SATA	1TB

< Back Next > Cancel Help

1. This screen shows the list of unused drives. Click the checkbox at the left end of the row that describes the drive(s) you want to designate as spare drives.
2. After making the selections, click Next > to open the Date & Time screen.

Set up date and time

The Set Up Date & Time page sets the real time clock (RTC) in the array. The date and time information is used to timestamp logs and events in the array.

Setup Array Wizard - Microsoft Internet Explorer

HSNM2 - Setup Array Wizard HITACHI

1. Introduction ▶ 2. Set up E-mail Alert ▶ 3. Set up Management Ports ▶ 4. Set up Host Ports ▶
5. Set up Spare Drive ▶ **6. Set up Date & Time** ▶ 7. Confirm ▶ 8. Finish

Enter the information to set date and time. When you select manually, enter the requested information.

* Date&Time: Set Automatically

Set Manually: Date: 2009 / 01 / 09
Time: 10 : 20 : 15

Keep current setting

* Required field

< Back Next > Cancel Help

1. Select the method of setting the date and time and enter the appropriate date and time for your location.
 - Select **Set Automatically** to use the date and time settings from the server on which Navigator 2 is installed.
 - Select **Set Manually**, and enter the date and time for your location.
 - Select **Keep current setting** to use the date and time that is currently set in the array clock.
2. Click **Next>** to continue to the confirmation pages.



NOTE: You can also set Time Zone and NTP (Network Time Protocol) after finishing the Initial Setup Wizard. Both the NTP and the Edit Date and Time dialog boxes can be used to set the time. The setting made last from either dialog box is the setting that will be used.

Confirm

The Confirm dialog box is divided into six pages, one for each of the settings dialog boxes described above. View the settings on each page and click **Next>** to view the next page or **<Back** to go back to the desired screen to change settings.



NOTE: You cannot change settings on the confirmation screens. You must go back to the original screens to make changes.

After you have reviewed all of the confirmation pages, click **Confirm** on the page to save the settings. Depending on the communication speed and network activity, it may take a several seconds to save the settings. When the settings are saved, the wizard displays the Finish screen.

Finish

This screen contains a message that the wizard has successfully completed the setup. Click **OK** to acknowledge the message and close the wizard.

Restoring the management console

Complete the following steps to restore the management console network environment:

1. Reset the IP address to its original setting. See the section titled [Installing Storage Navigator Modular 2 on page 5-57](#).
2. Reconnect the LAN cable to the management port on the array.

Reregistering the array

If you changed the IP address of the array as described in [Initial array setup on page 7-22](#), you must register the array again. Otherwise, skip this procedure.

1. Log out of Navigator 2, and close the browser.
2. Restart the browser and launch Navigator 2.
3. Enter the appropriate URL in the address field.
 - If you are using http, enter the following URL in the address field:
http://< IP address>:23015/StorageNavigatorModular/Login
where <IP address> is the IPv4 or IPv6 address of the management console.
 - <If you are using https, enter the following URL in the address field:
https://< IP address>:23016/StorageNavigatorModular/Login
where <IP address> is the IPv4 or IPv6 address of the management console.



NOTE: The https URL is invalid immediately after the installation. Refer to [Using SSL on page 7-48](#).

When you enter an IPv6 address, you must enclose the URL in brackets []
Example: http://[xxxx]:23015/StorageNavigatorModular

If you have the IPv6 address set to use DHCP and obtain an address automatically, simply delete the array from the Array List window and add it back in again.

After a few seconds, the login screen is displayed as shown in the following figure.

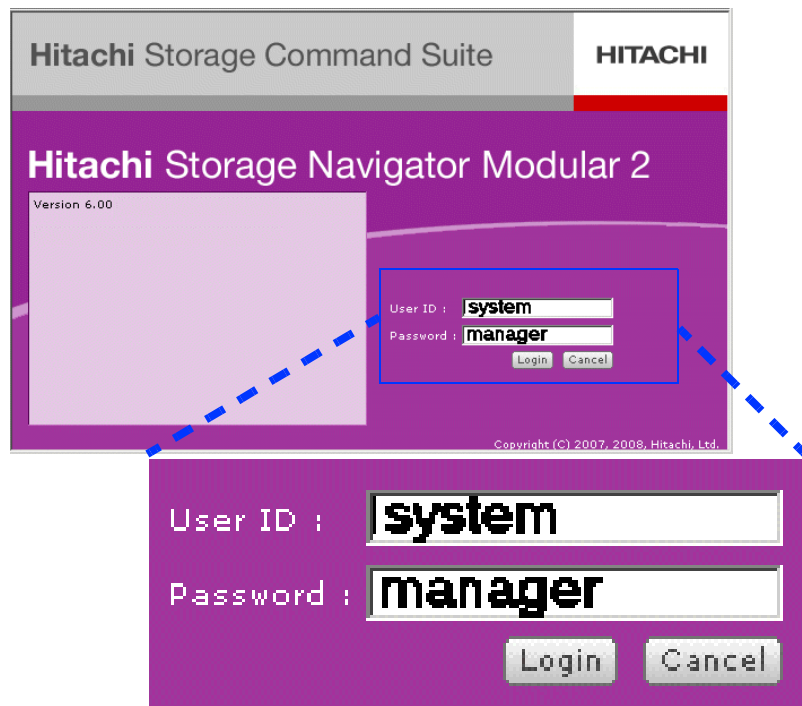

4. Enter the default administrator **user ID: system** (all lower case).
5. If you changed the administrator password, **enter your current password**. Otherwise, enter the default administrator password: **manager**, as shown above. After a few seconds, the Array List window is displayed.
6. In the Array List window, click the checkbox to the left of the name of the array whose settings you just modified, and click **Edit Array**. The Edit Array dialog box is displayed.

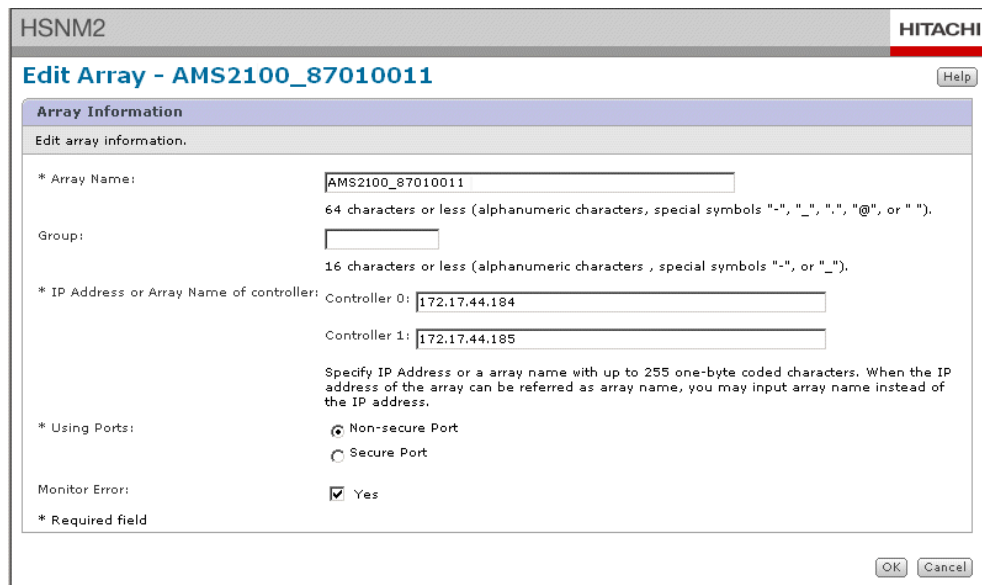

7. In the Edit Array dialog box, enter the IP addresses for controller 0 and controller 1 that you set in the [Set up Management Ports](#) screen in the Array Setup wizard.

Registering the array on the support website

This section describes the procedure to use Navigator 2 to register the array information on the Hitachi Data Systems Support site.

You must register the array information on the Hitachi Data Systems support site. This is required if you plan to download firmware, software, and documentation updates, and for ordering any needed replacement parts.



NOTE: If the management console is not connected to Internet, write down the information for registration and register it from a computer that is connected to the Internet.

Follow these steps to register an array on the support site:

1. Ensure that the management console has a connection to the internet.
2. Click the link below or open a browser and enter the following URL to access the Hitachi Data Systems Support Website login page.

<http://support.hds.com>.



NOTE: If you encounter a problem registering your base unit, please contact Hitachi Data Systems Global Services at:

- United States +1 866-371-7140
 - Europe / Middle East / Africa +44 (0) 1753 216053
 - All other Regions +1 858-621-7124
-

Cautionary note about system construction

This section offers a cautionary note about the system construction before connecting the AMS2100/AMS2300 to the host.

When using LUN Manager on a fabric switch connection

Observe the following when using LUN Manager on Fabric Switch connection:

- When connecting to the servers (HBA) or exchanging the HBA, connect to the servers (HBA) that can access to Disk Array after the LUN Manager setting, including WWN registration, completes.
- Zoning on Fabric Switch must be set as shown below to redirect access from the HBA that cannot be accessed to Disk Array by LUN Manager.

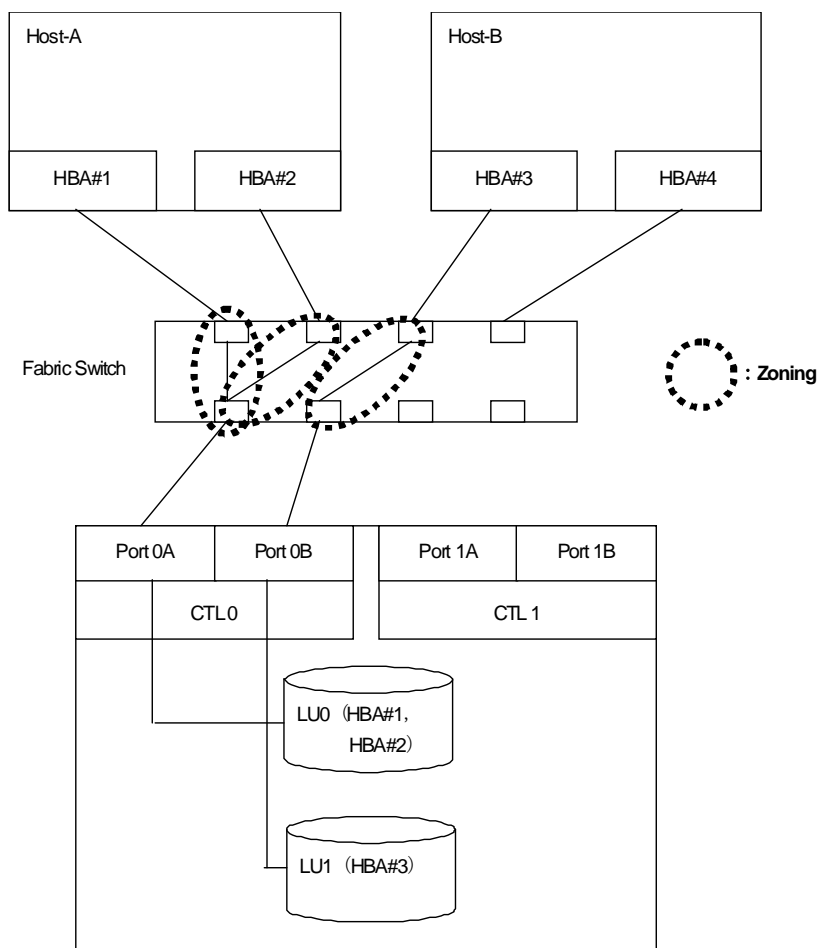

Option setting for improving I/O response time in small-scale configuration

The number of RAID Groups can be expanded in the AMS2000 series. To realize this scalability, it is designed to keep average throughput even when the multiplicity of I/O is high. However, you can improve the I/O response time using the Cache preferentially in cases where the number of RAID Groups is small — about one to three in the configuration — and the Write I/O load is low, or the load only grows momentarily.

By setting this option, the write data is stored as much as possible in the Cache, and it changes to the operation that suppresses the I/O issue to the drive. The collision of the host I/O and drive I/O may be reduced by suppressing the I/O issue to the drive, so that you may improve the Write I/O response time.

However, in the case of continuously writing the data volume greatly exceeding the cache memory size, the throughput may temporarily deteriorate. Therefore, you need to be careful when setting the option. Hitachi Data Systems recommends you set this option with your specific environmental conditions in mind.

The setting procedure is described below.

1. Select the array from the Hitachi Storage Navigator Modular 2, and then select the **Tuning Parameter** icon in the Performance tree. The Tuning Parameter window is displayed.
2. Click the Change Simple Tuning button.

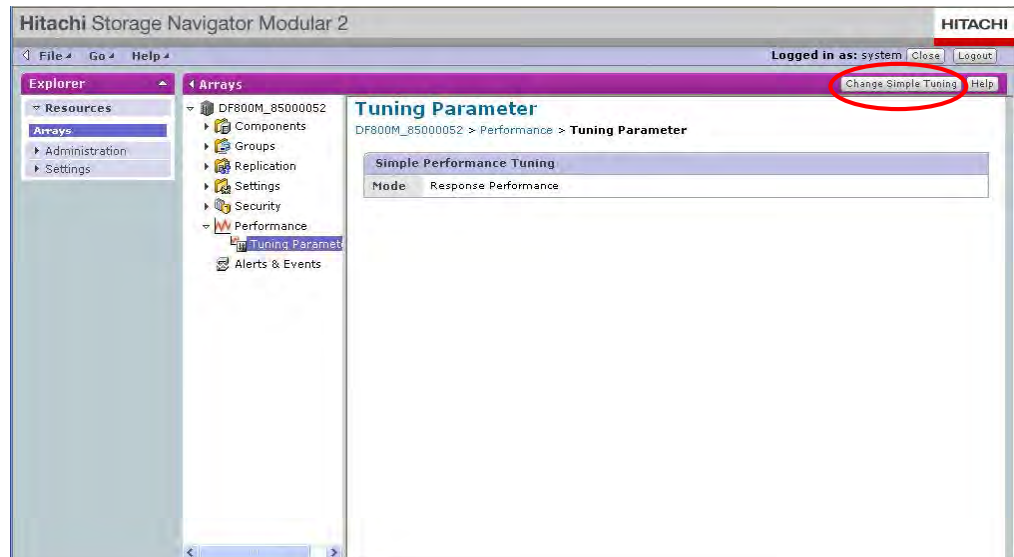

3. The Change Simple Tuning window is displayed. Turn ON the Response Performance Mode to improve the I/O response time.



4. Click the Close button.

The processor operation rate becomes high while operating in the Response Performance Mode compared to the rate in normal mode. When replacing the firmware, it may not be replaced because the processor operation rate is high. If you cannot replace it, Hitachi Data Systems recommends that you replace it again after changing the mode to normal.



NOTE:

- The Response Performance Mode is enabled only when the segment size is 16KB or less. Be careful when using it with CachePartitionManager.
- When changing from the Response Performance Mode to the normal mode, if the I/O load is heavy, you may not change the setting. In this case, perform it after the host I/O stops according to the error message.

A note on using Dynamic Disk

You cannot use Dynamic Disk on Windows Server 2008 while reducing the logical unit capacity.

A note on UNMAP Short Length Mode

The default status of the port option "UNMAP Short Length Mode" is as follows:

- The port which includes the host group for which the Windows is selected as platform: Enable (selected status).
- The ports other than the one described above: Disable (unselectable status).

Fabric Switch Connection Configurations

With Fibre Channel (8Gbps), using ARB (FF) becomes a standard on behalf of IDLE to reduce electrical noise. Therefore, the Fibre Channel (8Gbps) interface for this array supports the IDLE/ARB (link initialization/fillword). Do not set the Ports of Brocade Switch to mode 1 or mode 3 because the phenomenon where LinkUP cannot be executed will occur if mode 1 or mode 3 is set for the Ports of Brocade Switch.

This array supports the number of BB Credits listed in [Table 7-9](#).

Table 7-9: The Number of BB Credits

No	Topology	Type of ports	The number of credits		
			4 Gbps (2 Port)	4 Gbps (4 Port)	8Gbps (2 Port)/ 4 Port
1	Loop	NL_Port/FL_Port	4	20	40
2	Point to Point	N_Port/F_Port			

A note on deleting the RAID group expansion instruction after executing the RAID Group expansion instruction

The RAID group expansion processing is not performed after executing the RAID group expansion instruction, and you can only delete the waiting RAID group.

Additional storage configuration - optional tasks

The following table includes descriptions of the primary optional tasks to manage an array. These are explained in detail in the Navigator 2 online help and in the manuals listed in the [Accessing product documentation](#) section in the Preface of this manual.

Table 7-10: Additional Storage Tasks

Task	Description
Monitoring Alerts and Events	The Alerts and Events window displays information about errors and all events that have occurred in the array. It is a good idea to view this window on a regular basis to check for errors and whenever you receive an email or other alert that an error has occurred. It is also a good way to review all commands and actions that have been used to make changes to the array to help determine the cause of an error.
Checking the array status on page 7-36	The resources in an array include RAID groups and iSCSI targets (host groups). The procedures for managing these resources are explained in detail in the Managing Groups help page and other help pages that are linked from that page.
Managing replication on page 7-39	Replication is the process of copying data from one drive to another. See Managing replication in this chapter and also the Managing Replication help page in the Navigator 2 Online Help System for information and procedures to accomplish this task. One method of replication is called Copy On Write Snapshot. In addition to the information in this help system, see the manual: <i>Hitachi Storage Navigator 2 Storage Features Reference Guide for AMS</i>
Additional storage configuration - optional tasks on page 7-35	Most storage features that are preinstalled on the array have license keys installed with them. Some of the licenses are already enabled, but others are not. See Navigator 2 features on page 7-10 for details. You must enable the licenses before you can use the software. Optional software applications do not have the license keys installed. These keys must be installed on the array before the software can be used. The procedure to install a license key is described in the Navigator 2 Install Licenses help page.

Checking the array status

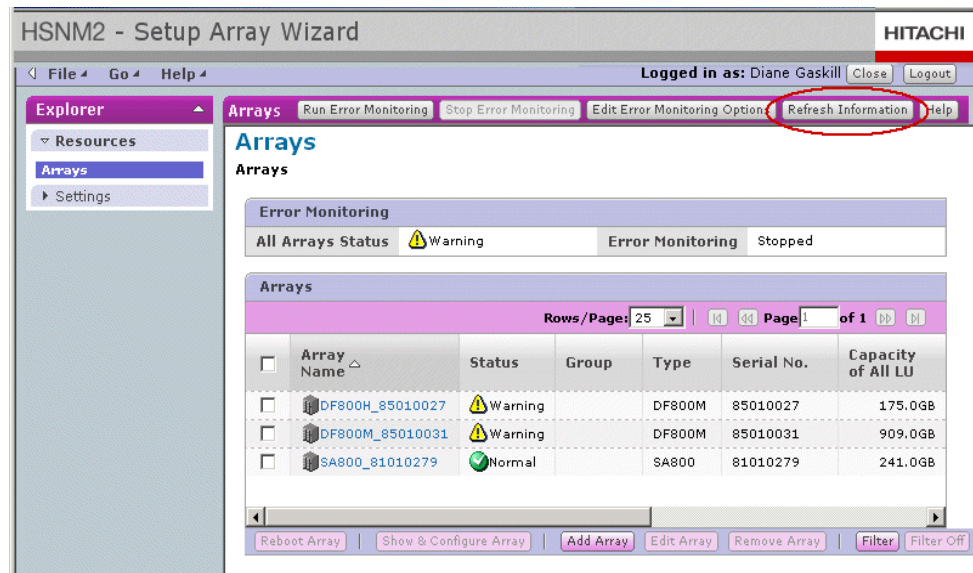

Hitachi Data Systems strongly recommends that you periodically check the array status in the Array List window. Whenever Navigator 2 is launched, queries the arrays that are registered in its database and updates the information in the Array List window. You can also update the information by clicking Refresh Information in the upper menu (see the above illustration).

In addition, the Navigator 2 Alerts and Events window displays information about errors and all events that have occurred in the array. It is a good idea to view this window on a regular basis to check for errors and whenever you receive an email or other alert that an error has occurred. It is also a good way to review all commands and actions that have been used to make changes to the array to help determine the cause of an error. See the Error Monitoring help page in Navigator 2 for detailed information.

Managing resources

The resources in an AMS 2100/2300 array include RAID groups and host groups.

Working with RAID groups

A RAID (Redundant Array of Independent Disk) group is a group of disk drives that constructs single or multiple parity groups. A RAID group can be considered as the actual RAID container for data protection, and the parity group as a partition of the container. This way, multiple LUNs can be created from each RAID group, and ported out to the same or different servers (hosts). This allows granularity in LUN sizes being obtained from the RAID group.

A logical unit, generally referred to by its logical unit number (LUN) is created within a RAID group.

Hitachi AMS 2000 Series base and expansion units are preconfigured at the factory with a single RAID group. You can use this predefined RAID group, delete it, or create your own. The following procedures provide basic instructions for working with RAID groups. For detailed information, please see the Navigator 2 online help or the manuals listed in the [Accessing product documentation](#) section of the Preface.

Displaying RAID group properties

To display the properties of a RAID group:

1. Select an array to manage.
 - a. If you are not working in the array you want to manager, click **Resources > Arrays** to display the Array List window. In this window, click the name of the array you want to manage.
 - b. If you are already working with the array you want to manage and the Array Properties window is displayed.
2. In the array tree, expand the **Groups** menu.
3. Select **RAID Groups**. The RAID Groups window is displayed. It shows the properties of the RAID group and lists all the LUNs that are assigned to that RAID group.
 - RAID level and parity group (example: RAID6 (2D+2P))
 - The total capacity of the drives in each RAID group
 - The total free space in each RAID group
 - The type of drive(s) assigned to this RAID group.

To display detailed data for a single RAID group:

1. In the RAID Groups window, click the name of the RAID group you are interested in. The properties window for the selected RAID group is displayed. The window should look similar to the following illustration.

The screenshot shows the Hitachi Storage Navigator Modular 2 interface. The main window displays the properties for RAID Group RG-000. The Summary section provides the following information:

Property	Value	Capacity	Total	Free	Value
RAID Group	000				1.0TB
RAID Level	RAID5				991.4GB
Parity Group	4D+1P				SAS
Number of Parity Groups	1				Host Access
Status	Normal				

Below the summary is a table of Logical Units:

LUN	Capacity	Stripe Size	Cache Partition	Pair Cache Partition	Status
0000	20.0GB	256KB	00	Auto	Normal
0001	20.0GB	256KB	00	Auto	Normal
0002	20.0GB	256KB	00	Auto	Normal
0003	100.0MB	256KB	00	Auto	Normal
0004	20.0GB	256KB	00	Auto	Normal

The Summary section of the RAID Group Window provides the information shown in [Table 7-11](#).

Table 7-11: RAID Group Properties

Feature	Description
RAID Group	This is the name of the displayed RAID group. The default name is RG-000.) Note: The Simple Modular Storage System can have only one RAID group.
RAID level	This is the number of the RAID level (1-6) that has been assigned to the RAID group.
Parity Group	This is the name of the parity group that has been assigned.
Number of Parity Groups	This is the number of parity groups that have been assigned to the RAID group (min - 1).
Capacity	This field displays both the total capacity of the hard drive(s) in the RAID group and the free space left on the drive(s).
Drive Type	This field displays the type of drive(s) contained in the RAID group. It can be either SAS or SATA. Both types cannot be contained in the same RAID group.

Creating a RAID group

This procedure assumes that the RAID Groups window is already displayed. If needed, see the instructions in [Displaying RAID group properties on page 7-37](#) to display the RAID Groups window.

To create a RAID group:

1. In the RAID Groups window, click **Create RG**. The Create RAID Group dialog box is displayed.
2. In the Create RAID Groups dialog box, enter appropriate information in the fields listed in the above table. See the on-screen instructions in the dialog box.

HSNM2 HITACHI

Create RAID Group Help

RAID Group Property

Enter the information for the RAID group to be created.

* RAID Group: 001
From 0 to max (array model type dependent)

RAID Level: RAID5

Parity Group: 4D+1P

* Number of Parity Groups: 1
From 1 to max (based on drive count)

Drives:

Automatic Selection: Drive Type: SAS Drive Capacity: 146GB

Manual Selection:

Assignable Drives

Rows/Page: 25 Page 1 of 1

Tray	HDU	Drive Type	Status
<input type="checkbox"/> 00	00	SATA (500GB)	Out of RAID Group
<input type="checkbox"/> 00	01	SATA (500GB)	Out of RAID Group
<input type="checkbox"/> 00	02	SATA (500GB)	Out of RAID Group

* Required field

OK Cancel

3. Click either **Automatic Selection** or **Manual Selection**.

4. Click **OK** to save the settings, close the dialog box, and return to the RAID Groups window, or click **Cancel** to exit without creating a RAID group.
5. If you click **OK** in step 4, a message box is displayed, asking you to confirm that you want to create the RAID group. Click **OK** to confirm or **Cancel** to close the window and exit without creating a RAID group.
6. When the RAID group has been created, another message box (not shown) is displayed, confirming that the RAID group has been created. Click **Close** to exit the window and go back to the RAID group window. You should now be able to see the new RAID group listed in the window.

Deleting a RAID group

To delete a RAID group:

1. Display the RAID groups window.
2. Click the checkbox(es) next to the name of the RAID group(s) you want to delete, and then click Delete RG at the bottom of the window.
3. A confirmation dialog box is displayed. Click **OK** to confirm that you want to delete the RAID group or click Cancel to exit without deleting the selected RAID group.
4. If you click **OK**, a second confirmation dialog box is displayed. This dialog box explains that the data on the drives included in this RAID group(s) will be deleted. Click **OK** to delete the RAID group(s) anyway, or click Cancel to exit without deleting the RAID group(s).
5. If you click **OK**, SNM2 deletes the selected RAID groups and then displays a Message confirming that the RAID groups have been deleted.

Managing replication

Navigator 2 provides access to multiple methods of backing up data. They are divided between two primary types: local and remote replication, as described below.

Replication is the process of copying data from one volume (logical unit, LUN) to another. See the Managing Replication help page in the Navigator 2 Online Help system for information and procedures for details and procedures to accomplish this task. Replication can be accomplished via three different storage features including Copy On Write Snapshot, True Copy, and True Copy Extend Distance. Detailed information about each of these storage features is located in the *Hitachi Storage Navigator 2 Storage Features Reference Guide for AMS*. This manual is listed in the [Accessing product documentation](#) section in the Preface and is provided in PDF format on the documentation CD that accompanies the array.

In particular, see the *Hitachi Navigator Modular 2 (SNM2) Storage Features Consolidated User's Guide* that is included on the documentation CD that is shipped with the array. It explains the following storage features:

- Audit Logging
- Account Authentication
- Cache Partition Manager
- Cache Residency Manager
- Data Retention
- LUN Manager
- Performance Monitor
- SNMP Agent Support
- Volume Migration

Local replication

Local replication includes two methods of backing up information: ShadowImage and SnapShot. These methods create a copy of a volume (logical unit) in an array to another volume in the same array. You can create an actual copy of a volume by using ShadowImage and can create a virtual point-in-time copy of a volume by using SnapShot. ShadowImage and SnapShot treat the source volume, also called Primary Volume, and its copy, which is called the Secondary Volume, as a volume pair. For example, you can a copy by creating a pair. For detailed information and instructions, see the help page Local Replication.

ShadowImage and SnapShot are optional storage features and require licenses to be installed and/or enabled before they can be used. See the introduction help page and the licenses help page for more information about setting up optional storage features.

Remote replication

Remote replication includes two methods of backing up information: TrueCopy Remote Replication and TrueCopy Extended Distance. These methods allow you to create a copy of a volume (logical unit) in the array. TrueCopy remote replication allows the volumes to be synchronous at all times, while TrueCopy Extended Distance allows the volumes to be asynchronous. Both methods treat the source volume, also called Primary Volume, and its copy, which is called the Secondary Volume, as a volume pair. For example, you can a copy by creating a pair. For detailed information and instructions, see the Remote Replication help page in Navigator 2.

TrueCopy remote replication and TrueCopy Extended Distance are optional storage features. See the Navigator 2 online help and the manuals listed in the [Accessing product documentation](#) in the Preface for more information about setting up these optional storage features.

Using the LUN manager

Using LUN Manager on a fabric switch connection

When connecting to the servers (HBA) or exchanging the HBA:

1. Configure the LUN Manager settings including the WWN registration
2. Connect the servers that can access the array.
3. As shown in the following illustration, set the **Zoning on Fabric** switch to change the access from HBA that cannot be access to Disk Array by LUN Manager.

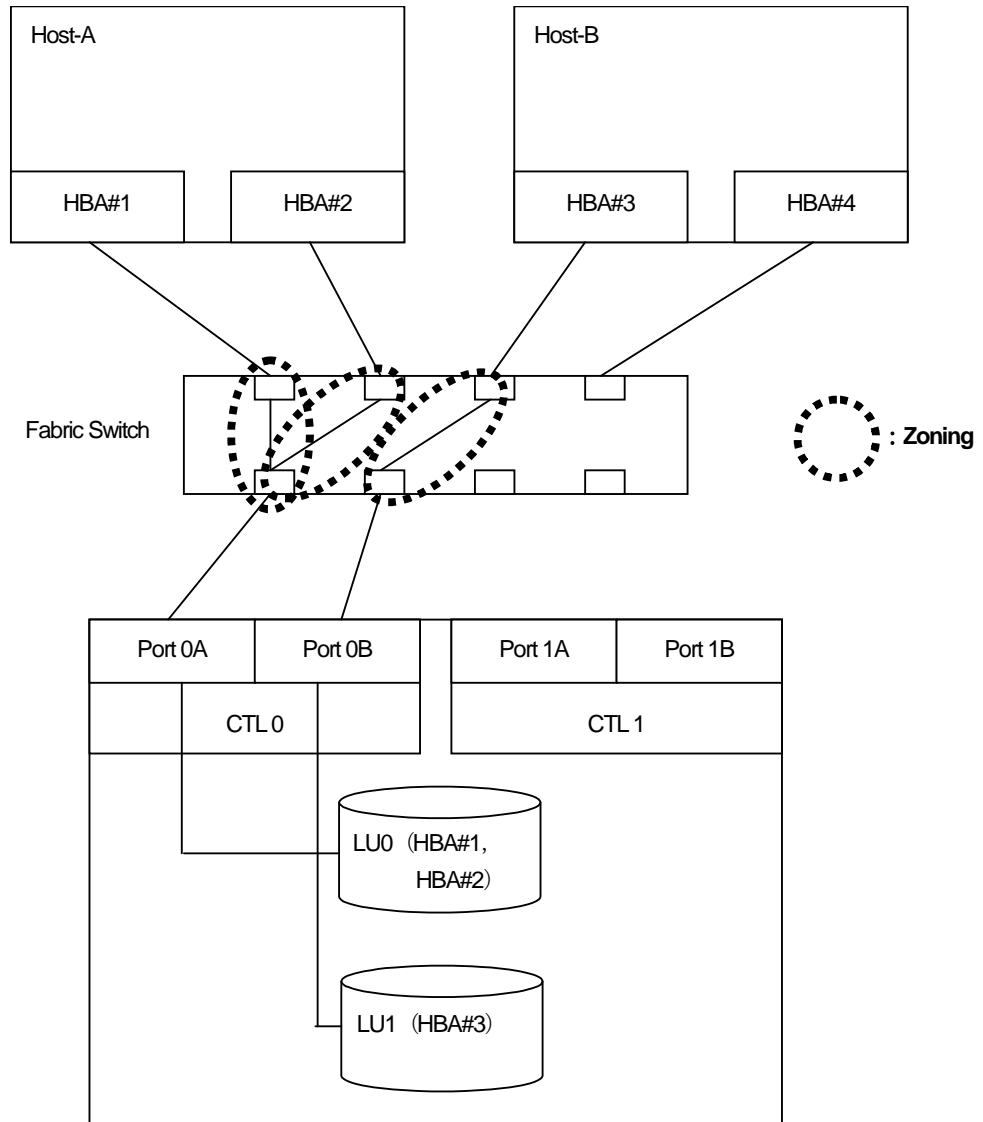

Backing up your data

The AMS 2100/2300 supports two types of backup operations:

- Local backup - copying LUNs to another drive in the same array.
- Remote Backup - copying LUNs to a drive in another array.

Both of these operations are easy to accomplish using the wizards in Navigator 2. You can also copy data using the True Copy and Snapshot features in Navigator 2. See the Navigator 2 online help and the True Copy and Snapshot manuals that are included in the AMS 2100/2300 documentation set for details.

Performance tuning in small-scale configurations

This section provides information to improve the I/O response time in small-scale AMS 2100/2300 configurations.

The number of RAID Groups can be expanded in the AMS 2100/2300 array. To realize this scalability, the system is designed to keep the throughput on average even when the I/O is high. However, the I/O response time may delay in the configuration that the number of RAID Groups is small, for example, one to three.

In this case, the I/O response time can be improved by setting this option. However, when continuously writing data to the cache, the amount of data can greatly exceed the cache memory size. This can temporarily cause the the throughput to deteriorate. Therefore, be careful when setting this option. Hitachi Data Systems recommends that you consider the traffic in the network environment before setting this option.

Setting the performance tuning option

1. In Navigator 2, display the Array List window and then select an array. The Array Properties window and the explorer tree are displayed. If needed, see [First time storage configuration - required tasks on page 7-18](#).
2. In the explorer tree, expand the **Performance** menu and select **Tuning Parameter**. The Tuning Parameter window is displayed.
3. Expand the Tuning Parameter menu to show the three options. These are described in [Table 7-12](#).

Table 7-12: Tuning Parameters

Item	Description
Multi-Stream	Multi-Stream is a function that sets some parameters for multi-streaming for selected systems or logical units
System Tuning	System Tuning is a function that sets some parameters for all systems.
LU Ownership	Logical Unit Ownership is a function that sets some parameters to logical unit ownership.

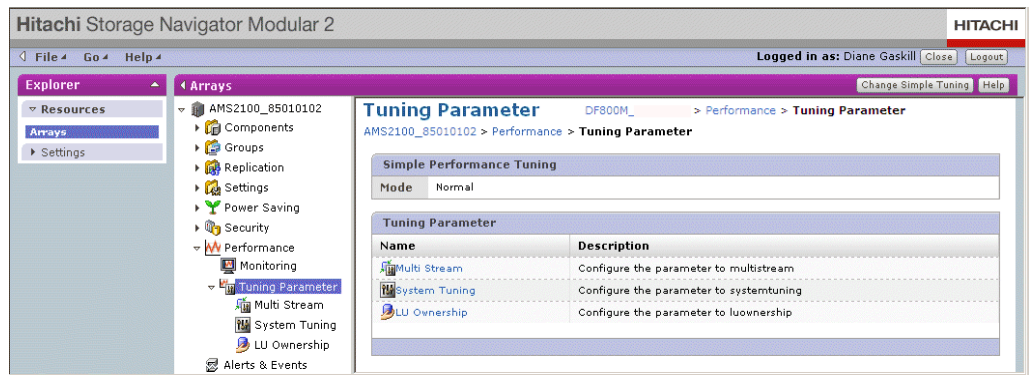

Viewing the Tuning Parameter Mode

You can view the current Simple Tuning mode from the Summary portion of the Tuning Parameter window. There are two available modes, which may be set using the Change Simple Tuning button:

- Normal
 - Response Performance
1. To change the Simple Tuning mode, click **Change Simple Tuning** (upper right corner of the window). The Change Simple Tuning window is displayed. Select **Response Performance** to improve the I/O response time only if the system meets the following conditions:
 - Dirty data are at 50%
 - The dirty data stop opportunity is 50%
 - The Multi-stream mode of the system is Read/Write
 2. Click **OK**.

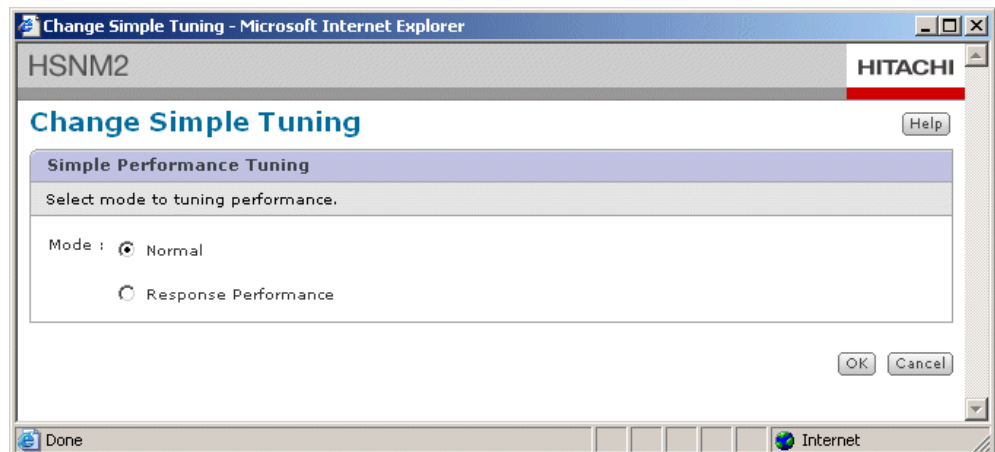



NOTE: The response performance mode is enabled only when the segment size is 16 kB or less. Be careful when using it with Cache Partition Manager.

If you attempt to change the mode from response performance mode to the normal mode while the I/O load is heavy, the setting may not change and an error message is displayed. If this happens, follow the instructions in the error message, wait until after the host I/O stops, and change the setting again.

The processor speed becomes high while operating in the response performance mode compared to the rate in the normal mode. During this time, it may not be possible to upgrade the firmware. Hitachi Data Systems recommends that if you cannot upgrade the firmware while operating in the response performance mode, change the mode to normal and then upgrade the firmware.

If the mode setting is successful, a confirmation message is displayed. Click **Close** to exit the message box and return to the Tuning Parameters window, where you can confirm that the setting has changed.

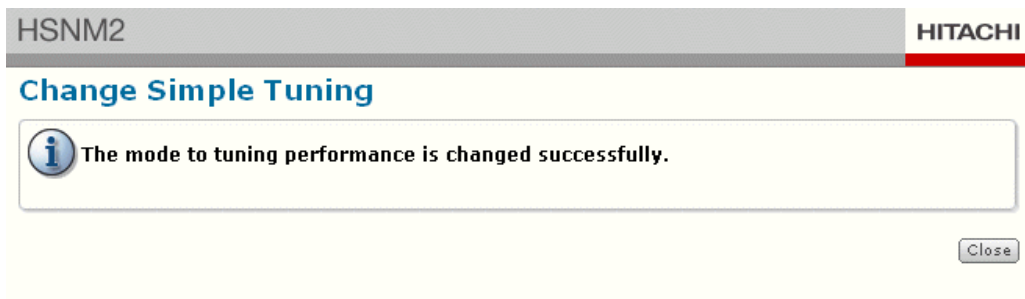

Multi-Stream configuration

Use the Multi Stream window to configure certain parameters that change the multi-stream scope, initialize parameter settings, and edit multi-stream options.

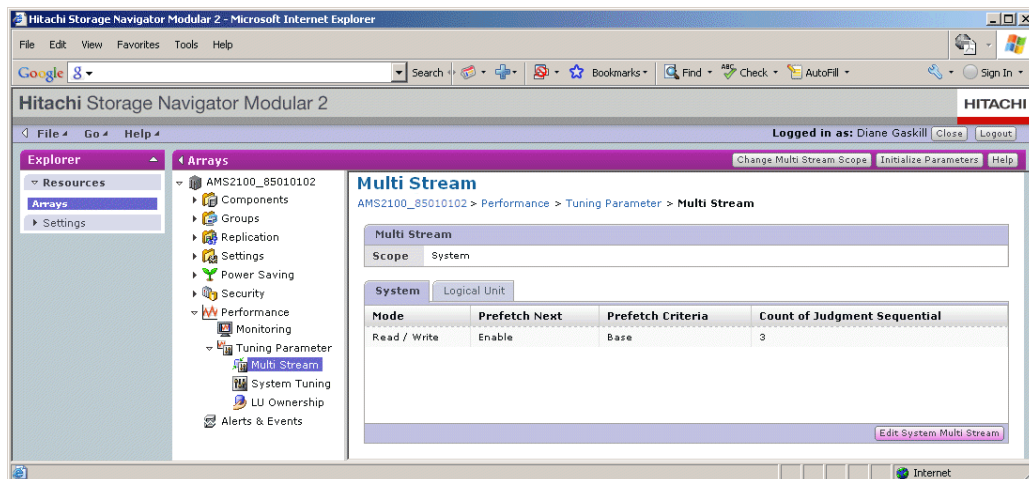

To display or set the multi-stream:

1. In the Array List window, select the array for which you want to display the multi stream and then click Show & Configure Array. The window and explorer tree for the selected array is displayed.
2. In the navigation tree, click Performance. The Performance window is displayed.
3. Click Tuning Parameter. The Tuning Parameter window is displayed.
4. Click Multi Stream. The Multi Stream window is displayed. The Multi Stream window displays the System tab by default.
5. You can view the current scope of the multi-stream feature from the Summary portion of the Multi Stream window. There are two available modes, which may be set using the Change Multi Stream Scope button:
 - System
 - Logical Unit

System tuning

You can set some parameters for system tuning and also initialize parameter from the System Tuning window.

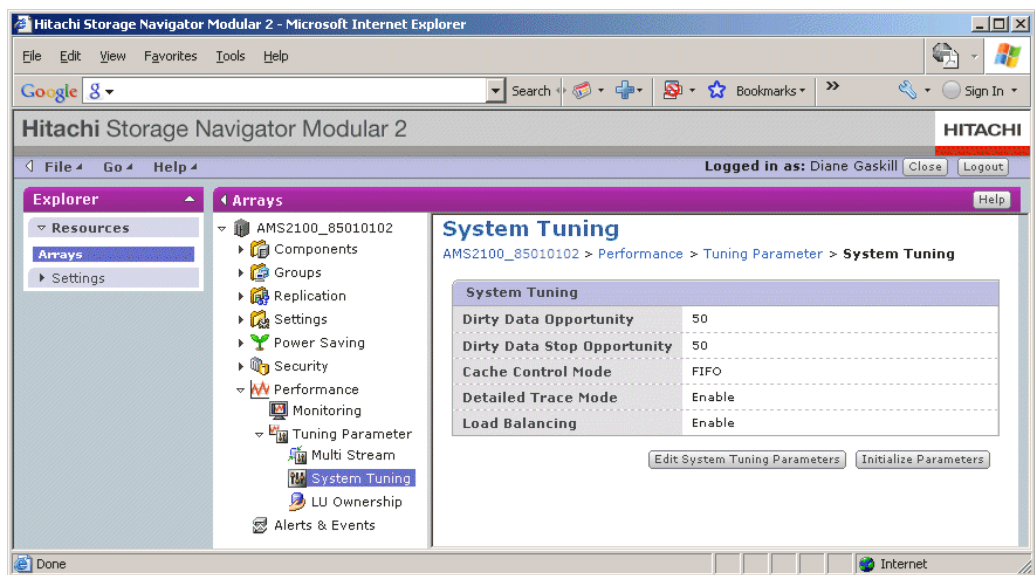

To display or to set the system tuning:

1. In the array window, select the array for which you want to display the system tuning and then click Show & Configure Array. The window and explorer tree for the selected array is displayed.
2. Click Performance. The Performance window is displayed.
3. Click Tuning Parameter. The Tuning Parameter window is displayed.
4. Click System Tuning. The System Tuning window is displayed. The System Tuning portion of the System Tuning Window provides the information in [Table 7-13](#).

Table 7-13: System Tuning

Item	Description
Dirty Data Opportunity	Amount of dirty data opportunity.
Dirty Control Stop Opportunity	Number of dirty control stop opportunity.
Cache Control Mode	The mode selected of the cache control.
Detailed Trace Mode	This is the mode of detailed trace.
Load Balancing	This is the type of load balancing.
Load Balancing Monitoring Time	A user-configurable value that sets the time to monitor load balancing. The default value is 3 minutes.

Logical unit ownership

In the Logical Unit Ownership window, you can change certain parameters of ownership to logical unit.

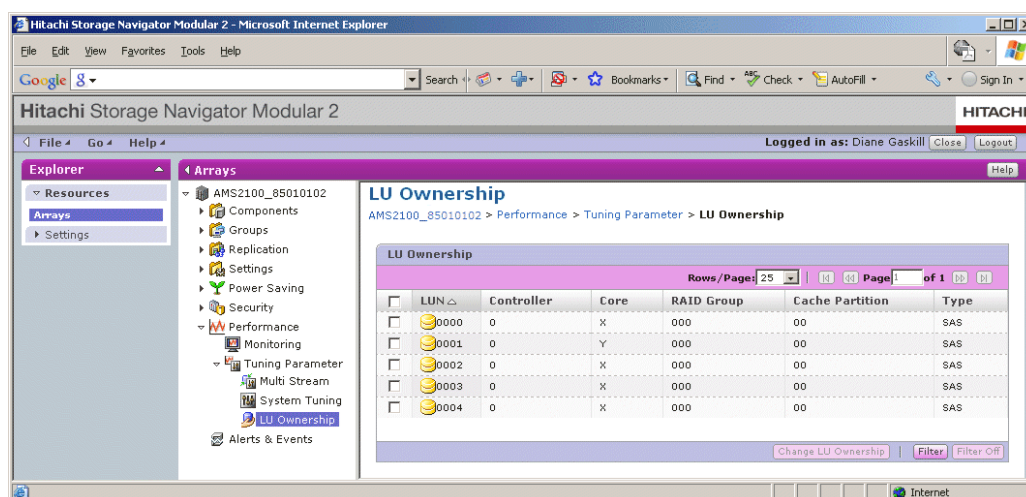

To display or to set the system tuning:

In the array window, select the array for which you want to view the system tuning and then click Show & Configure Array. The window and explorer tree for the selected array is displayed.

In the navigation tree, click **Performance**. The Performance window is displayed.

Click **Tuning Parameter**. The Tuning Parameter window is displayed.

Click **LU Ownership**. The LU Ownership window is displayed. The LU Ownership window provides the information in [Table 7-14](#).

Table 7-14: Logical Unit Ownership

Item	Description
LUN	The LUN column in the table displays the name of the logical unit.
Controller	This column displays the controller number assigned to the LUN
Core	This column displays the core number assigned to the LUN. When core don't exist, this column displays "r;N/A".
RAID Group	This is the name of the displayed RAID group. The default name is RG-000.)
Cache Partition	This column displays the number of cache partitions assigned to the LUN (Range is 0 - nnn)
Type	This field displays the type of drive(s) contained in the RAID group. It can be either SAS or SATA. You cannot mix drive types within the same RAID group.

Using SSL

Hitachi Data Systems recommends that you use SSL (Secure Socket Layer) communication to encrypt data transferred via the user management LAN to manage the array. The general procedure for using SSL communication with the array is listed here and described in detail below.

1. Change the Server Certificate and Private key for the array.
2. Change the Navigator 2 Web server configuration.
3. Change the Navigator 2 Java applet configuration.
4. Manage the array through SSL communication.



NOTE:

1. When updating the Hitachi Storage Navigator Modular 2 GUI, you must perform step 2 and 3 again. For more details, see the *Hitachi Storage Navigator Modular 2 Graphical User Interface (GUI) User's Guide*.
 2. SSL communication impacts the processor more than normal communication. Therefore, frequent communication using SSL may deteriorate I/O performance.
-

Launching Navigator 2

When launching Navigator 2 specify the following URL:

```
https://xxxx:23016/StorageNavigatorModular/Login
```

where xxxx: is the IP Address that you used when returning the storage management when you returned the storage management PC network environment. See [Restoring the management console on page 7-28](#).

For the URL, specify a host name or IP address of Navigator 2. Do not specify a loop back address such as localhost and 127.0.0.1 or [::1]. When you specify a loop back address such as localhost or 127.0.0.1, the Web screen is displayed, but the Applet screen is not displayed.



NOTE: In case of inputting IPv6 address to the address of the WEB browser, it is necessary to specify the URL that put xxxx of the URL in brackets ([]).

```
https://[xxxx]:23016/StorageNavigatorModular/Login
```

Navigator 2 security settings

To set up SSL:

1. In the Array List window, select an array to manage.
2. When the Arrays window is displayed, expand the navigation tree to display the set of menu items.
3. Expand the Security menu item.
4. Click Secure LAN. The Secure LAN window is displayed, as shown here.

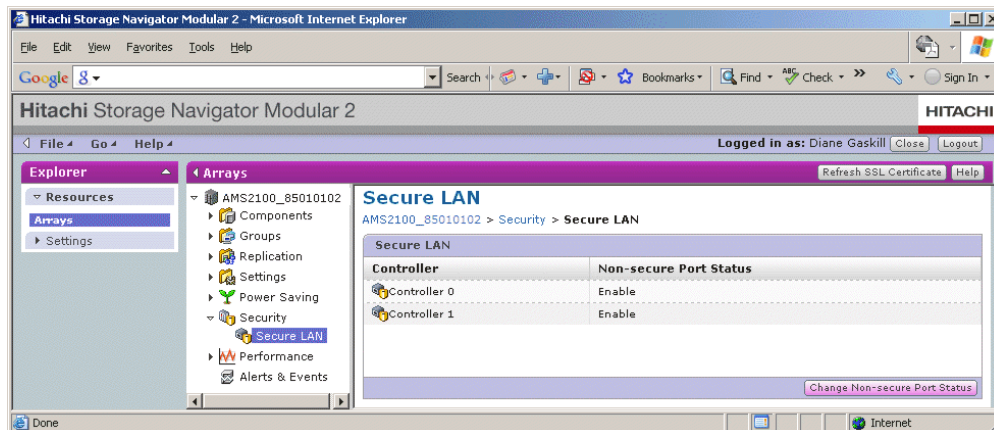

Changing the server certificate and private key

Complete the following easy steps to create a server certificate/private key using OpenSSL. After creating the server certificate/private key, update the server certificate/private key on the array.



NOTE:

- Only the x.509v3 certificate and RSA key are supported.
- The certificate, private key and public key are read integrally up to the total of 8192 bytes.
- The Certificate Revocation List (CRL) is unsupported.

1. Install OpenSSL and configure your environment that enable OpenSSL to use. Refer to OpenSSL Project (<http://www.openssl.org>).
2. Create a private key using the RSA algorithm. You can select a key length of 512, 1024, or 2048 bits.



NOTE: You cannot use the private key encrypted by the Triple DES algorithm, etc. For example, with a 2048-bit key length, the command would be

```
openssl genrsa -out privkey.pem 2048
```

3. Create an x.509 v3 server certificate. Use the certificate signed by the Certificate Authority (CA) or the certificate with your signature for the server certificate depending on the purpose.
 - a. When using the server certificate signed by the CA:

Create a Certificate Signing Request (CSR). Submit the CSR (“csr.pem” in the example) to the CA and obtain the signed server certificate. For example, when the expiration date is 365 days (one year), enter:

```
openssl req -new -days 365 -key privkey.pem -out csr.pem
```

The obtained signed server certificate is described as “cacert.pem” hereinafter.
 - b. When using a self-signed certificate, create a certificate with your signature. Use the certificate only for the local environment or test. For example, when the validity period is 365 days (one year)

```
openssl req -new -x509 -key privkey.pem -out cacert.pem -days 365
```

4. Delete the path phrase (option). When you have generated the encrypted private key in step 1 or you use the existing encrypted private key, delete the path phrase in the following procedure. For example, delete the path phrase after copying the private key with another name (execution example with Unix) as follows:

```
cp -p privkey.pem privkey.pem.org
openssl rsa -in privkey.pem.org -out privkey.pem
```

5. Integrate the server certificate and private key. The array can read only the file (hereinafter called SSL certificate file) that integrates the server certificate and private key. Even if using the server certificate signed by the CA, create the file integrated with the private key in the following procedure. For example, when integrating the server certificate and private key as "server.pem" (execution example with Unix), enter:

```
cat cacert.pem privkey.pem > server.pem
```

6. Use Navigator 2 to update the server certificate and private key. If you update the server certificate and private key when the normal port is invalid, you may not be able to connect it to the array when there is a problem on the server certificate or private key. Therefore, be sure to enable the normal port and update it.
 - a. To enable the normal port, connect the port to the array from the secure port and select the secure LAN icon in the security tree. The secure LAN window is displayed.

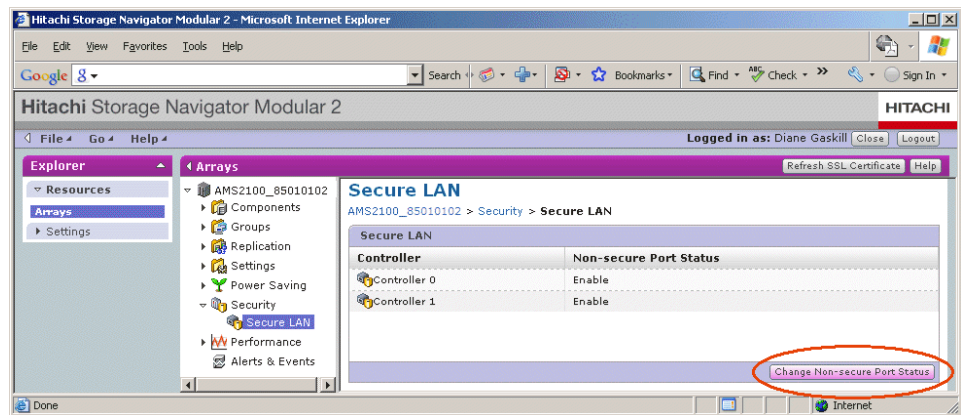

- b. When the normal port status is invalid, click **Change Non-secure Port Status** as shown above. The Change Non Secure Port Status Dialog box is displayed.
 - c. As shown in the following figure, check **Enable non secure port of controller0** and **Enable non secure port of controller1**. Then click **OK**. This enables the normal ports.

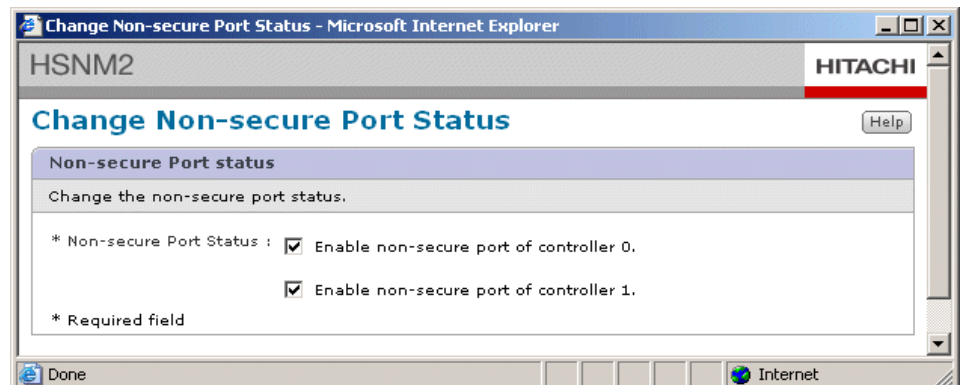

Updating the server certificate and private key

To update the server certificate and private key:

1. Click the “Refresh SSL Certificate” button from the secure LAN window.

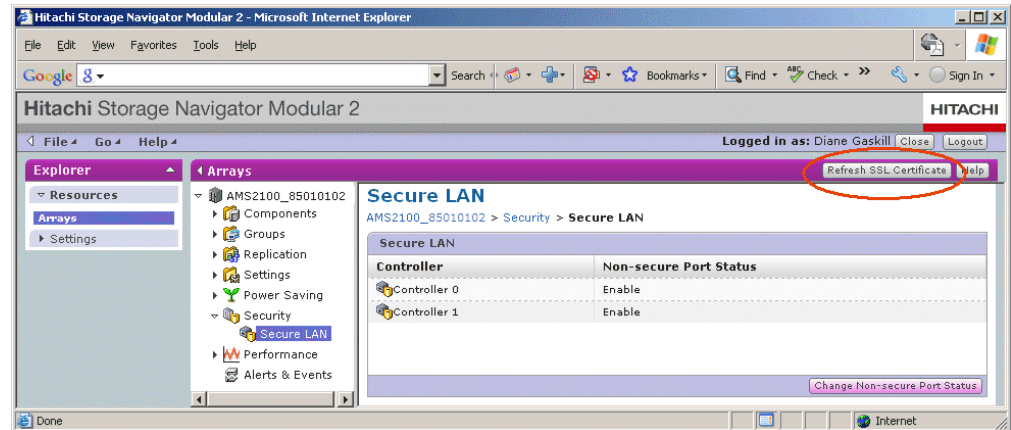

2. The SSL certificate update window is displayed. Specify the SSL certificate file created in step 3 in the above procedure and update the server certificate and private key.

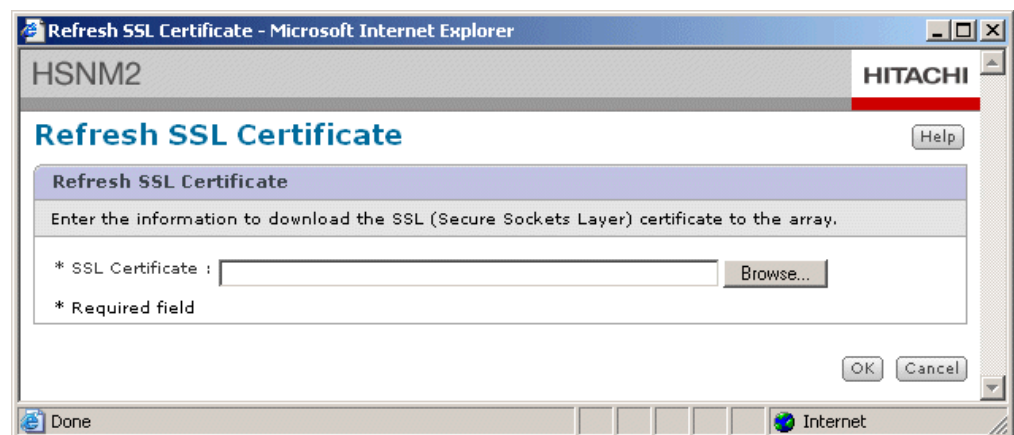

Changing the Navigator 2 web server configuration

Change the Web server configuration according to Setting the Server Certificate and Private Key on p. 3-17 of the *Hitachi Storage Navigator 2 Advanced Settings User's Guide*.

Changing the Navigator 2 Java applet configuration

Change the Java Applet configuration according to Setting the Server Certificate and Private Key for Applet Screen of Navigator 2 on p.3-20 in *Hitachi Storage Navigator 2 Advanced Settings User's Guide*.

Setting the day and time

The array has a clock that is used to time-stamps array logs. Using Hitachi Storage Navigator Modular 2, you can configure the settings for this clock. You can also set the array clock to match the time of the server running Hitachi Storage Navigator Modular 2 or configure the clock to use a Network Time Protocol (NTP) server. You can register up to two NTP servers (server 1 and server 2), however, the array management port must be able to communicate with them.

If neither NTP server 1 nor NTP server 2 is set, the array does not reflect time differences or adjust daylight saving time automatically.

The array receives Coordinated Universal Time (UTC) time from the NTP server and calculates time differences and daylight saving time of each country inside the array. However, since the time differences and the daylight saving time calculated by the array do not always follow the latest legal system of each country, a gap from the local time of each country may occur even though the NTP server adjusts the time. When the time gap occurs, even if the NTP server and the array synchronize, check the time and date of the clock by the display of Hitachi Storage Navigator Modular 2 and perform Edit Date and Time as needed.

When you perform Edit Date and Time, release the NTP server setting in the date and time setting (both server 1 and server 2) on Edit Time Zone & NTP window. If the NTP server is still set, the date and time set manually may be changed.

If data inconsistency occurs in the array cache memory due to a problem such as the subsystem going down or a combination of power outage and battery failure, the array setting returns to the setting that was in effect when the array started for the first time. In these cases, check and reconfigure the date and time setting after recovering the array from these conditions.

To configure the date and time settings:

1. In Storage Navigator Modular 2, and click **Settings > Date & Time**. The Date & Time window is displayed. You can set and display the status of the array clock function in this window.

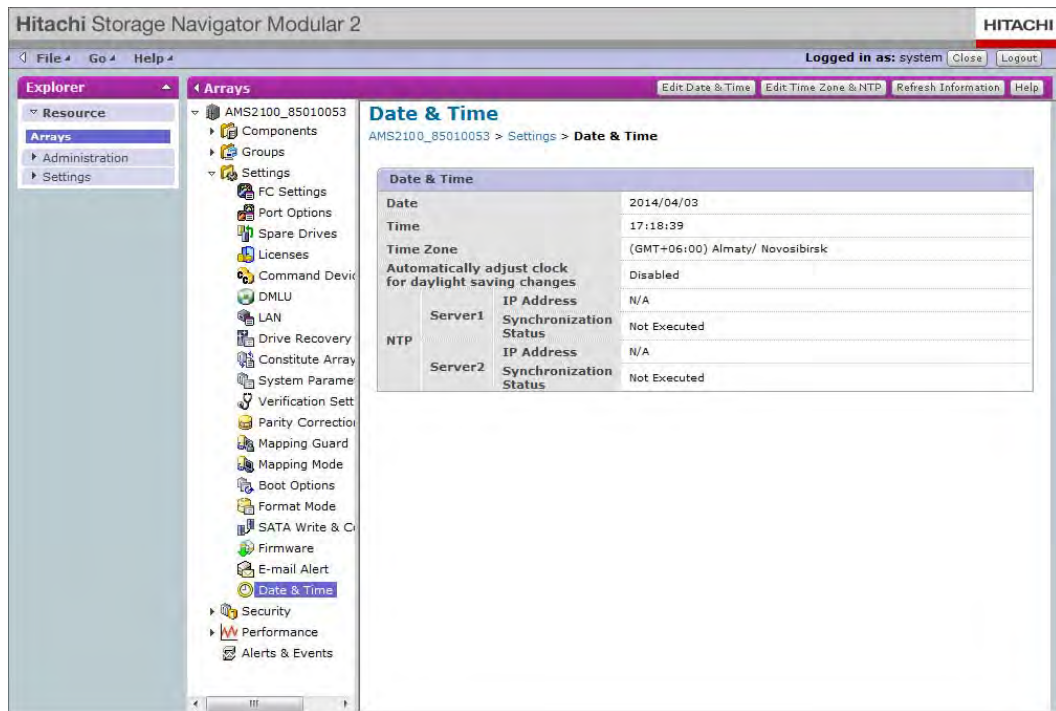

Table 7-15: Date & Time

Item	Description
Date	The date of the array clock is displayed.
Time	The time of the array clock is displayed.
Time Zone	The time zone set in the array is displayed.
Automatically adjust clock for daylight saving changes	Whether Automatically adjust clock for daylight saving changes of the array is enabled or disabled is displayed.
NTP	The information of the NTP server 1 and the NTP server 2 registered in the array are displayed.
IP Address	The IP address registered for the NTP server is displayed. When the IP address is not registered, N/A message is displayed.
Synchronization State	The synchronization status (success or failure) of the time when the array communicates with the NTP server last time is displayed. If it does not communicate with the NTP server after setting the NTP server or starting the array, Not Executed message is displayed.

The Array performs the synchronization timing by communicating to the NTP server at the time of the following events.

- Setting NTP server (specify IP address of NTP server) and editing NTP server.
- Starting the array.
- Every 24 hours after initially starting the array (for every 24 hours from here on).

If the synchronization status is a failure, check whether the IP address of the NTP server is correct, and confirm that the network connection between the array and the NTP server is operational.

Setting functions in the Date & Time window are described below.

Edit Date & Time

Click **Edit Date & Time** in the Date & Time window. When the Edit Date & Time window appears, set the date and time of the array clock.

The screenshot shows the 'Edit Date and Time' window in the HSNM2 interface. The window title is 'Edit Date and Time' and it features a 'Hitachi' logo. Below the title is a 'Date and Time Settings' section with a 'Help' button. The settings include a radio button for 'Set Automatically' (selected) and a radio button for 'Set Manually'. The 'Set Manually' option is expanded to show 'Date' (01/04/15) and 'Time' (15:51:17) input fields. A 'Required field' asterisk is present. 'OK' and 'Cancel' buttons are at the bottom right.

When you set the time of the server on which Hitachi Storage Navigator 2 is installed automatically, select Set Automatically. When you enter the date and time manually, select Set Manually and then enter the values. In case of Set Manually, the value displayed in the input column by default is same as the date and time when Edit Date & Time window is displayed.

Edit Time Zone & NTP

Click **Edit Time Zone & NTP** in the Date & Time window. When the Edit Time Zone & NTP window appears, set the time zone for the array clock function or the configure the array to an NTP server.

Edit Time Zone and NTP

Help

Time Zone and NTP Settings

Enter the information to set the time zone and IP address of NTP (Network Time Protocol) servers.

* Time Zone : ▼

Automatically adjust clock for daylight saving changes

IP Address of NTP Server : Set Server1

Set Server2

* Required field

OK Cancel

Set the time zone from the pull-down list in the Edit Time Zone & NTP. You can set the checkbox to adjust the array clock for daylight saving time (summer time) depending on the time zone.

If you use an NTP server, check the checkbox and enter the IP address of the NTP server. You can register up to two NTP servers (server1 and server 2). The array management port must be able to communicate with the NTP servers. Once a day, the array queries server 1 and adjusts the array clock. If the array cannot communicate with server 1, the array queries server 2 and adjusts the array clock.

After changing the setting, click **Refresh Information** in the Date & Time window for a while, and check whether the date and time are set as specified and the result of the synchronization with the NTP server.

Refresh Information

This button updates the items shown in the Date & Time window.

Other storage management operations

Other storage management operations include creating, deleting, and managing host groups, logical units (LUNs) and data pools, LUN expansion, See [Navigator 2 features on page 7-10](#) and [Storage features on page 7-11](#) for a complete list of the features supported on an AMS 2100/2300.

These operations are described in detail in the *Hitachi Navigator Modular 2 (SNM2) Storage Features Consolidated User's Guide* that is included on the documentation CD that is shipped with the array. In addition, the Navigator 2 online help included detailed procedures to use these features.

Uninstalling Navigator 2

If you need to reinstall or upgrade the software, you must first uninstall the currently installed software. See the following instructions.

To uninstall Navigator 2:

1. Close all Navigator 2 windows, including any help windows that are open.
2. Stop all Navigator 2-related services.
 - a. Locate the file \.....HiCommand\Base\bin\hcmdssrv.exe. The default location is:
c:\Program Files\HiCommand\Base\bin\hcmdssrv.exe
 - b. In a command (DOS) window that is started from the above directory, enter the command:
hcmdssrv /stop
3. When the services stop, select Start > Settings > Control Panel > Add/Remove Programs.
4. Wait until the list is populated (this can take several minutes, depending on the number of installed applications).
5. Select Hitachi Storage Navigator Modular 2.
6. Click Remove Program.



NOTE: The removal process can take several minutes. During this time, the progress indicator may appear to stop for a minute or more. Please let the program run to completion.

Troubleshooting

This chapter provides information to help you identify and resolve problems that you may encounter with a Hitachi Adaptable Modular Storage 2100/2300 Storage System. This chapter includes the following key topics:

- ❑ [Getting help](#)
- ❑ [Troubleshooting tables](#)
- ❑ [Troubleshooting flowcharts](#)
- ❑ [Recovering from failures](#)
- ❑ [Troubleshooting based on LED indications](#)

Getting help

If you have difficulty with any of the procedures included in this chapter, or if a procedure does not provide the answer or results you expect, please contact the Hitachi Data Systems Customer Support team. See the [Getting help](#) section in the Preface for information about accessing the support portal.

Troubleshooting tables

Table 8-1 lists common problems and their solutions. Detailed solutions are described in this chapter. The solutions include flowcharts and other instructions to assist you to solve these problems.

Table 8-1: Problems and Solutions

Symptom	Possible Cause	Action
Missing or damaged parts	<ul style="list-style-type: none"> Packing error Shipping damage 	If any of the contents listed on the packing list that is included with the unit are missing or damaged, contact your place of purchase.
A failure other than an array failure occurs	No power to host and/or array	<ol style="list-style-type: none"> Check that the host and the array are turned on. Ensure that power cables to the equipment are connected. Ensure that the power source is operational.
	Communication failure with host	<ol style="list-style-type: none"> Verify that the port activity LEDs on the Fibre Channel data ports being used are ON. If not, try a different Fibre Channel data port. Check the LUN Manager, mapping and LUN settings.
Array or part has failed	Array or part has failed	<ol style="list-style-type: none"> Start Navigator 2. If it fails to start, see Navigator 2 does not start, below. Go to the Explorer pane and select Resources > Arrays. In the Array List window, check for a failed array. If you find one, select Components > Trays. From the Alerts screen, click Details to check for additional failed parts. Read any detailed information about the failed part. If the failed component is a drive, order a replacement drive from the Web Portal at http://support.hds.com.
An unidentified failure has occurred	Software failure	<ol style="list-style-type: none"> If using preinstalled software (see Features and benefits on page 1-11), refer to the documentation for that product. Turn off the AMS 2100/2300 array. Verify that the front panel Power LED goes OFF. If the Power LED is ON, disconnect both power cables and verify that the front panel Power LED is OFF. Turn on the AMS 2100/2300 array and verify that the Ready LED goes ON. If these steps do not resolve the problem, see Array or part has failed, above.

Table 8-1: Problems and Solutions (Continued)

Symptom	Possible Cause	Action
Navigator 2 does not start	Communication failure with host or management console	<ul style="list-style-type: none"> • Check and reset communications settings • Check and reconnect LAN cables. Replace if needed. • Check LEDs and take appropriate action. See the LEDs section in this table. • Check and restore power to equipment as needed. • Be sure the computer acting as the management console meets the minimum requirements described in Prerequisites. • Check the settings of your browser. • Verify that the correct IP address was entered in the browser address field. • Verify that the Navigator 2 server is working. • Verify that the host has Java Runtime Environment (JRE) version 1.6 (update 2) installed. This is a free download from http://java.sun.com/javase/downloads/index.jsp. • If these steps do not fix the problem, you may need to reinstall the Navigator 2 software.
	Corrupt Navigator 2 installation	Reinstall Navigator 2. See Chapter 7, Configuration .
Navigator 2 does not run	Incorrect communication setting: Negotiation	Check the negotiations settings on the management console, and array. Make sure they are the same. The default value for the negotiation is Auto .
	Incorrect value set for the IP address, subnet mask, or default gateway of array	Set a suitable value for the customer's environment for the IP address, subnet mask, and default gateway of array. [IPv4 default value] controller #0: IP address: 192.168.0.16 Subnet Mask: 255.255.255.0 Default Gateway: 0.0.0.0 controller #1: IP address: 192.168.0.17 Subnet Mask: 255.255.255.0 Default Gateway: 0.0.0.0 [IPv6 default value] controller #0: IP Address: Auto controller #1: IP Address: Auto
	Communication failure with host or management console	<ol style="list-style-type: none"> 1. Check and reset communications settings. 2. See next section in this table.

Table 8-1: Problems and Solutions (Continued)

Symptom	Possible Cause	Action
<p>Navigator 2 cannot communicate with the array</p> <p>In addition to this table, see the flowchart Figure 8-2: Flowchart - Navigator 2 Cannot Connect to an Array on page 8-10</p>	iSCSI LAN cables broken or not properly connected	If using iSCSI connections, connect a category 5e or category 6 LAN cable to the RJ-45 connector marked LAN and the management console
	One or more units are powered off or do not have power.	<ol style="list-style-type: none"> 1. Check the array power cables, power sources, power switch, and Power LED. 2. Check whether other devices in your network, such as a router or switch, are the cause of the problem. 3. Turn off the array. Verify that the front panel Power LED goes OFF. If the Power LED stays ON, disconnect both power cables and verify that the front panel Power LED is OFF. 4. Turn on the array, wait about 4 minutes for the POST to complete, and verify that the Ready LED goes ON. 5. If these steps do not resolve the problem, see Array or part has failed, above.
	Communication failure: the array is set to use the DHCP server	<ul style="list-style-type: none"> • When the array is set to use the DHCPv4 server, connect with the IP address assigned by the DHCPv4 server. When using the DHCPv4 server, it is recommended that the array be set to statically (Static) assign IP address. • If the IP address is not assigned from the DHCPv4 server to the array when the array is set to use the DHCPv4 server, Navigator 2 cannot be connected to the array. Consult with your network administrator, and review the DHCPv4 server settings. • The default value is DHCPv4: Off (uses a Static IP address)
	Communication failure: an incorrect value set for the IP address, subnet mask, or default gateway of array	<p>Set a suitable value for the customer's environment for the IP address, subnet mask, and default gateway of array.</p> <p>[default value]</p> <p>controller #0: IP address: 192.168.0.16 default gateway: 0.0.0.0 Subnet Mask: 255.255.255.0</p> <p>controller #1: IP address: 192.168.0.17 default gateway: 0.0.0.0 subnet mask: 255.255.255.0</p>
	Communication failure: the array is set to use the same IP address as other arrays or hosts.	When the same IP address as the other arrays or hosts is set for the array, Navigator 2 cannot be connected correctly to the array. Set the array IP address to one that is not used by any other array or hosts on the LAN.
	TCP/UDP port filtering is being performed on the network switch.	<ul style="list-style-type: none"> • The standard default TCP port number for Navigator 2 is 2000. The secure port is 28355. Set a suitable value for the customer's environment. • Be sure to change the port number in the environment using the Cisco SIP Phone.

Table 8-1: Problems and Solutions (Continued)

Symptom	Possible Cause	Action
	Is the Search Array being performed across the IPv6 routers?	The Auto Search Array of IPv6 uses link-local scope multicast. The IPv6 router is unable to transfer this multicast to other local link, so the IPv6 router is unable to search array across the IPv6 router. In case of between different local links, register the array by the static address search.
Host cannot access storage	Communication failure with host or management console.	<ol style="list-style-type: none">1. If you are using Fibre Channel, verify that the port activity LED on the used Fibre Channel data ports is ON or flashing.2. Check that all Fibre Channel cables are connected securely at both ends.3. If you are using iSCSI, ping the array from the host. If the ping fails, verify that the host is communicating with the array at the appropriate IP address.4. Check whether other devices (routers, switches, etc.) in your network) are the cause of the problem.5. If these steps do not fix the problem, contact Technical Support. See Getting help in the Preface of this manual.

Table 8-2: LED Failure Indications

Unit	Symptom	Possible Cause	Action
In addition to this table, also see Troubleshooting based on LED indications on page 8-13 .			
Base Unit	Power LED OFF	<ol style="list-style-type: none"> 1. Array power switch OFF 2. Power supplies not plugged in 3. PDB switch or breaker OFF 4. No electric supply to rack 	<ol style="list-style-type: none"> 1. Ensure that the array power switch is ON 2. Check that the power cable connections to the array and the PDB are secure. 3. Ensure that the PDB switches are ON 4. Verify electricity supply to the rack. Work with facility administrator to restore power. 5. If these steps do not fix the problem, contact Technical Support. See Getting help in the Preface of this manual.
	Ready LED OFF	Array failure	Please contact Hitachi Data Systems Technical Support. See the Getting help section in the Preface of this manual.
	Ready LED slow blink	Not a failure. Firmware download is complete. The array is fully operational.	Use the array normally.
	Ready LED fast blink	Not a failure. The firmware is being updated (do not turn off the array).	Wait until the light is ON steady before attempting to replace parts or use the array.
	Warning LED ON or slow blink	Nonserious error. The base unit can continue to operate.	See the Alerts & Events window in Navigator 2 for information about the error.
	Warning LED fast blink	The firmware is being updated.	Do not turn off the array.
	Alarm LED ON	A serious error has occurred in the array.	Please contact Hitachi Data Systems Technical Support. See the Getting Help section in the Preface of this manual.
Disk Drive	Alarm LED	The drive has failed	Back up data and replace the drive.
Backup Battery	Ready LED blinking slowly (1 blink per second)	Not a failure. The battery is not fully charged.	Allow battery to charge fully.
	Ready LED OFF or high-speed blinking (8 blinks per second):	Abnormal status	Replace battery.

Table 8-2: LED Failure Indications (Continued)

Unit	Symptom	Possible Cause	Action	
Power Supply	Ready LED OFF	No power to power supply	1. Ensure that power cables to the equipment are connected. 2. Ensure that the power source is operational.	
	Ready LED blinking	Not a failure. Means that power is connected to the power supply.	Use normally	
	Alarm LED ON	The power supply has failed.	Replace the power supply.	
Controller	C-Power LED ON	The cache memory is backed up.		
	RST LED blinking	Not a failure. Blinks while the base unit is resetting.	Wait until reset completes before using the base unit.	
	Link LED OFF	Link status is abnormal	Check LAN cable connections and communications settings. See Navigator 2 cannot communicate with the array.	
	ACT LED OFF	No data is being transferred.		
	LCT LED blinking	6 (slow)	Voltage on the control unit is abnormal. (Reset of the control unit is not canceled.)	Replace the controller
		1 (fast) ^a	SRAM error.	
		2 (fast)	ENC hard error.	
3 (fast)		Firmware error in flash memory.		
4 (fast)	CUDG error in ENC.			
LCT LED ON	Boot section error in the ENC firmware, a RAM error, or ENC hard configuration error.			
Expansion Unit	Power LED OFF	1. Array power switch OFF 2. Power supplies not plugged in 3. PDB switch or breaker OFF 4. No electric supply to rack	1. Ensure that the ENC cables are connected from the base unit to the expansion unit and that Ensure that the array power switch is ON 2. Check that the power cable connections to the expansion unit and the PDB are secure. 3. Ensure that the PDB switches in the rack are ON. 4. Verify electricity supply to the rack. Work with facility administrator to restore power. If these steps do not fix the problem, contact Technical Support. See Getting help in the Preface of this manual.	

Table 8-2: LED Failure Indications (Continued)

Unit	Symptom	Possible Cause	Action
	Locate LED ON	Indicates that a non-fatal failure in the expansion unit, but which does not stop the unit from operating. Indicates that the expansion unit has been added to the array with the power turned on (this is not an error).	

a. When blinking fast, the LED is on for 400 ms and off for 200 ms for each fast blink. After the number of fast blinks has completed, the LED is off for one second.

Troubleshooting flowcharts

The following section provides step-by-step flowcharts that can assist you in solving two common problems with Navigator 2.

Navigator 2 does not start

The flowchart in [Figure 8-1](#) provides a series of troubleshooting steps to follow if Navigator 2 does not start when you enter the login URL in your browser. The main things to look for are communication failure with the host or a corrupt installation.

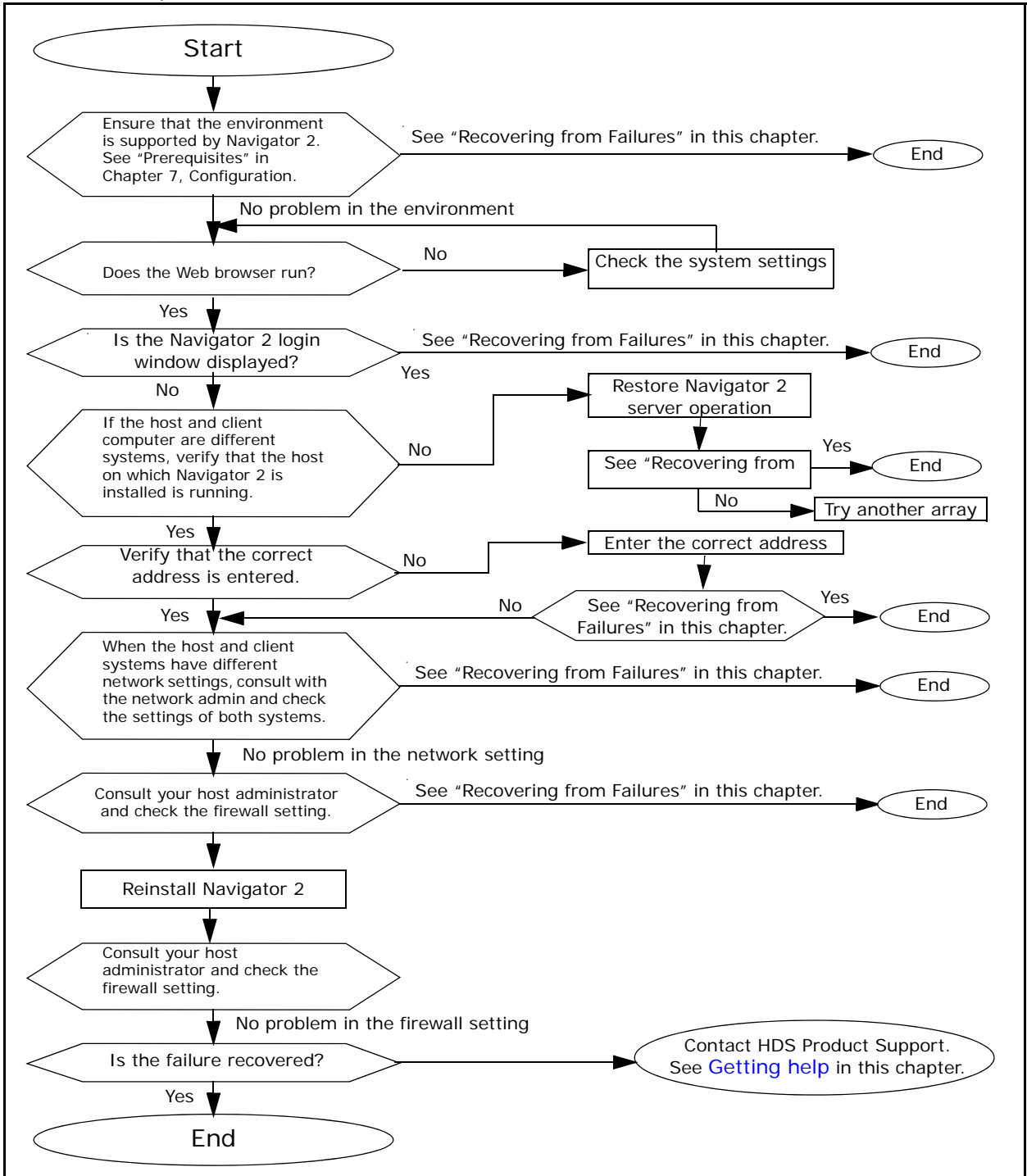

Figure 8-1: Flowchart - Navigator 2 Does Not Start

Navigator 2 cannot connect to an array

The flowchart in Figure 8-2 provides a series of troubleshooting steps to follow if Navigator 2 runs but cannot connect to an array.

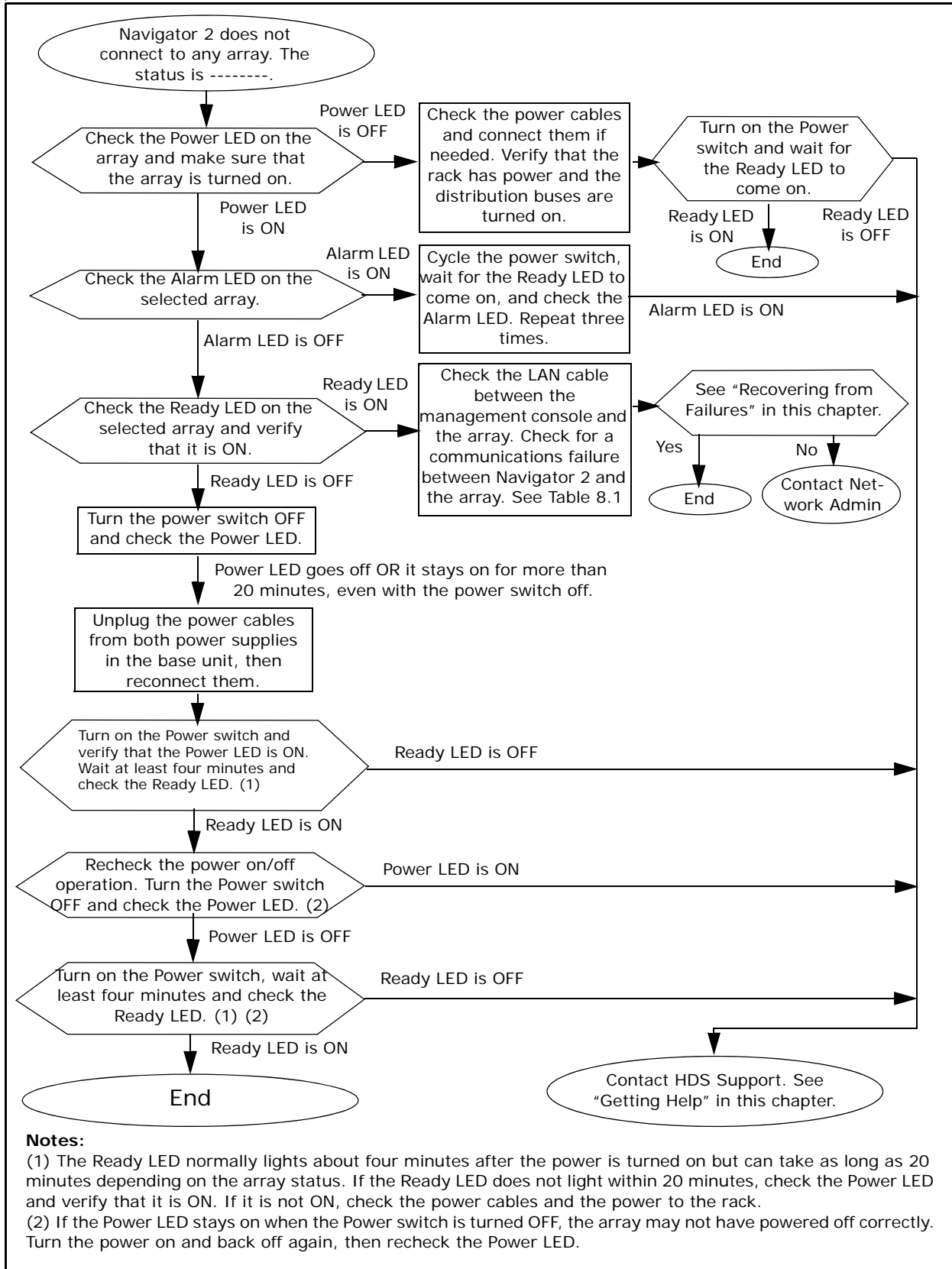

Figure 8-2: Flowchart - Navigator 2 Cannot Connect to an Array

Recovering from failures

An array failure may have occurred if one or more of the following occurs:

- The AMS 2100/2300 array sends an email alerting you to a failure.
- The **Alarm** or **Warning** LED on the front panel is ON.
- The **Ready** LED on the front panel is OFF.
- You experience performance deterioration with the AMS 2100/2300 array.
- A LUN cannot be recognized.
- A host cannot see a Fibre Channel data port on the AMS 2100/2300 array.

If one or more of these actions occurs, perform the following steps to recover from the failure:

1. Log in to Navigator 2. Enter the following URL in the address field in the browser:

```
http://<IP address of management console PC>:23015/  
StorageNavigatorModular/Login
```

2. The Array List window is displayed.



NOTE: If Navigator 2 does not start, a communication failure with the Navigator 2 server may have occurred or the Navigator 2 server may not be started normally. See Navigator 2 does not start in [Table 8-1: Problems and Solutions](#), on page 8-2 and [Figure 8-1: LED Failure Indications](#), on page 8-9.

3. In the **Arrays** area, check the status and serial number of the array where the failure occurred (see [Figure 8-3 on page 8-11](#)).

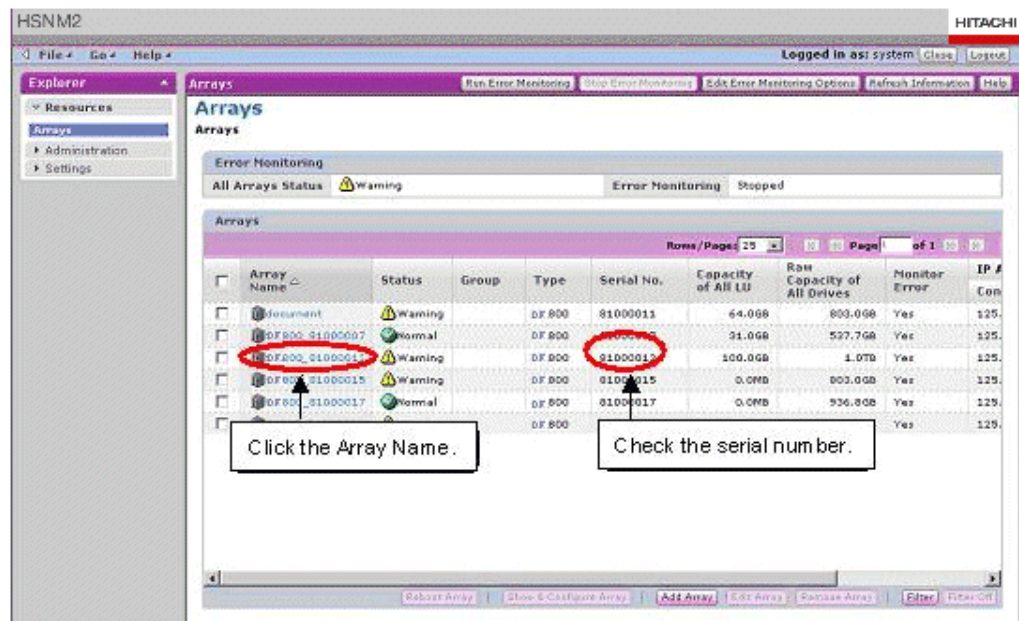

Figure 8-3: Locating the Array Name and Serial Number



NOTE: If Navigator 2 cannot access the AMS 2100/2300 array, the array may be turned off or there may be a network failure between Navigator 2 and the array.

4. If you received an email about the failure or used SNMP to detect the failure, check that the hardware serial number in the email/SNMP matches the one on The AMS 2100/2300 array (see [Figure 8-3 on page 8-11](#)).
5. Check the status column of the system that matches the hardware serial number checked in the previous step.
 - **Normal** = The AMS 2100/2300 array is operating normally. The fault may have occurred between the array and the host. See “A failure other than an array failure occurs” in [Table 8-1:Problems and Solutions, on page 8-2](#).
 - Navigator 2 cannot access the AMS 2100/2300 array. The **MAIN SW** switch may be set to the OFF position or a network failure may have occurred between the host and the array. See “Navigator 2 cannot communicate with the array” in [Table 8-1:Problems and Solutions, on page 8-2](#).
6. From the Arrays area shown in [Figure 8-3 on page 8-11](#), click the name of the array. When the next screen appears, click either **Alerts & Events** in the Array List window or **Check for Errors** in the Common Array Tasks area. In the **Alert Parts** tab, check for the failed part, such as a disk drive (see [Figure 8-4](#)).
 - If a disk drive is shown, replace the drive. See [Adding a disk drive](#) in chapter 9.
 - If the AMS 2100/2300 array is shown, the array is faulty and should be replaced.
 - If neither appears in the failure list window, a software failure may have occurred. See [An unidentified failure has occurred](#) in [Table 8-1:Problems and Solutions, on page 8-2](#).

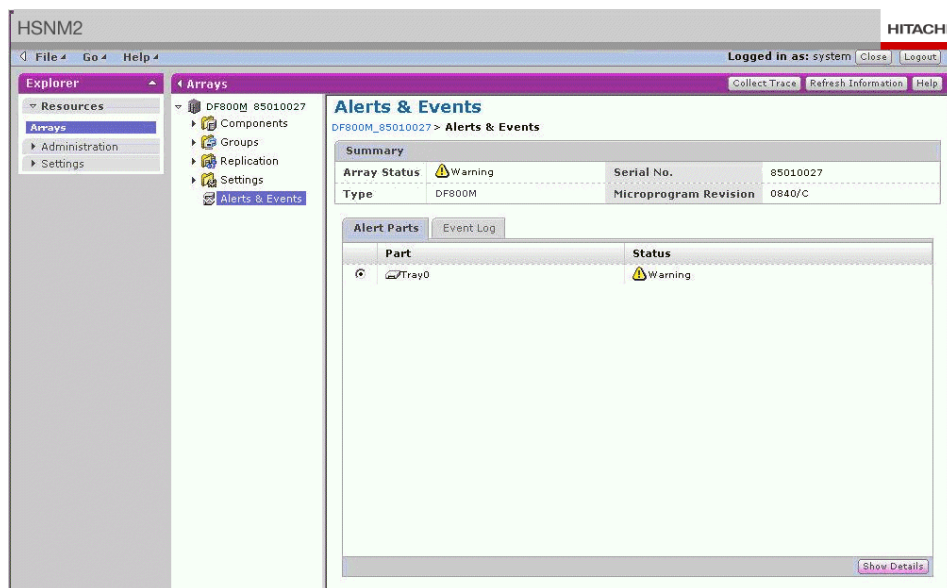

Figure 8-4: Example of the Failure Parts List Tab

- If an entry appears in the failure parts list window, click **Show Details** in the lower right corner of the screen for detailed information (see [Figure 8-5](#)). To remove the information, click **Close**.

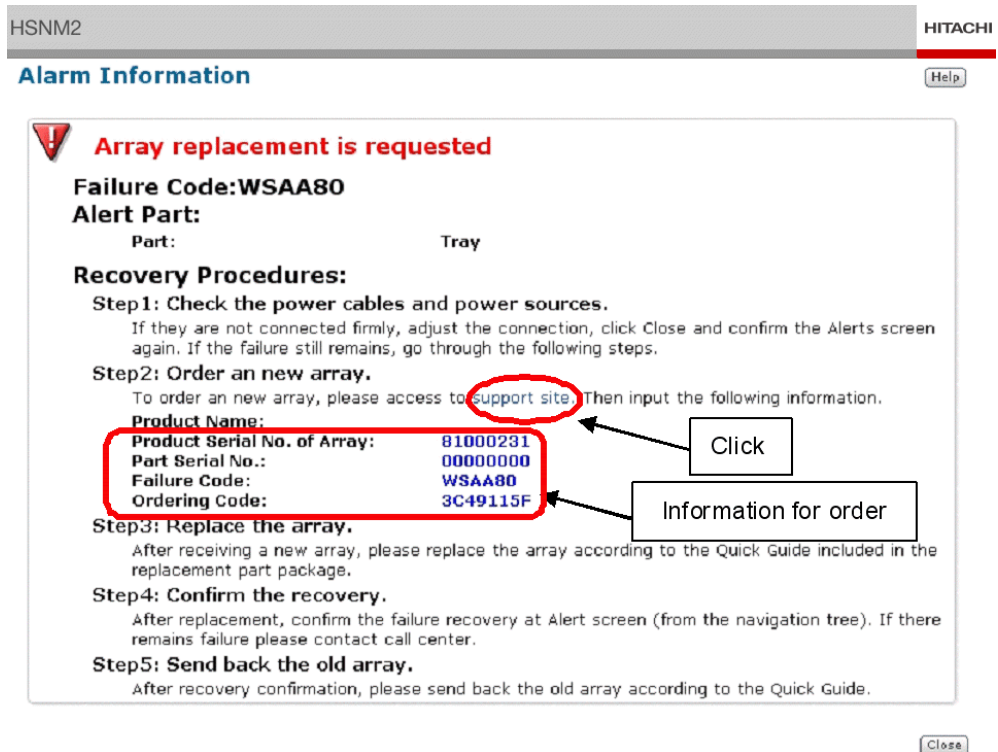

Figure 8-5: Example of an Alarm Information Window

Troubleshooting based on LED indications

This section provides step-by-step procedures to help determine the cause of failures that are indicated by the LEDs on the array. This section is intended to be used along with [Table 8-2: LED Failure Indications, on page 8-6](#).

Verify that a failure is recovered after taking the appropriate actions for the following LED indications.



When a base unit is used as the remote unit in a TrueCopy remote replication/TrueCopy Extended Distance configuration, restarting the base unit can cause the following events:

- Both paths of TrueCopy remote replication/TrueCopy Extended Distance are blocked.
 - At the time the path is blocked, Navigator 2 sends a failure notice to the users whose email addresses are configured in the Alerts and Events window in Navigator 2. The alert contains information regarding the Email Alert and SNMP Agent Support features, and TRAP. Follow the instructions in the email alert. After the remote unit has restarted, the path blockade automatically recovers and the paths are available for use.
 - If the pair status of TrueCopy remote replication/TrueCopy Extended Distance is PAIR or COPY, the pair status changes to PSUE.
 - When the base unit must be restarted, change the pair status of TrueCopy remote replication/TrueCopy Extended Distance to PSUS, and then restart the unit.
-



NOTE: When the Power Saving storage feature is used, if you restart the base unit while the spin-down is in progress, the spin-down may fail because it recognizes the host immediately after the unit starts.

After the spin-down has completed, check the RAID Groups and make sure that none of them are set to the “Normal (command monitoring)” power saving status. Then restart the unit. If the spin-down fails, start the spin-down again.

The power LED does not turn on

1. Set the main switch to On.
2. Is the POWER LED on the base unit on?
Yes: Go to step 10.
No: Power on the host computer.
3. Is the POWER LED on the base unit on?
Yes: Go to step 10.
No: Set the main switch to Off.
4. Check the PDB to verify that electricity is being supplied to the unit.
5. Verify that the AC cable is correctly connected to the power supply socket and the equipment.
6. Set the main switch to On.
7. Is the POWER LED on the base unit on?
Yes: Go to step 10.
No: Set the main switch to Off.
8. Contact Hitachi Data Systems Technical Support. Go to step 10.
9. Is the READY LED on?
Yes: Continue to use the equipment in its current operational state. If the READY LED (green) blinks at a high pace, the download of the ENC firmware is executed. Even when the READY LED (green) blinks, the

subsystem is operational.

No: Refer to (3) READY LED does not turn on or READY LED has turned on once and then turn off off.

10. End of procedure.

The power LED has turned off

1. Is electricity supplied to the equipment?
Yes: Go to step 2.
No: Supply electricity to the unit, and then restart the unit. Go to step 2.
2. Set the main switch to Off.
3. After waiting for more than one minute, set the main switch to On.
4. Is the POWER LED on the base unit on?
Yes: go to step 5.
No: Set the main switch to Off.
5. Call your maintenance engineer. Go to step 7.
6. Is the READY LED on the base unit on?
Yes: Continue to use the equipment in its current operational state. If the READY LED (green) blinks at a high pace, the download of the ENC firmware is executed. Even when the READY LED (green) blinks, the subsystem is operational.
No: Refer to Ready LED does not turn on (next section)
7. End of procedure.

Ready LED does not turn on

This procedure is also used when the Ready LED has turned on once and then turns off.

1. Is the Power LED on the base unit on?
Yes: Go to step 2
No: Go to step 4 in The Power LED does not turn on.
2. Is the Alarm LED on the base unit on?
Yes: Refer to Alarm LED has turned on .
No: Go to step 3
3. Does the Ready LED (green) on the base unit blink at high speed?
Yes: Wait for up to 30 to 50 minutes until the Ready LED (green) on the base unit lights because the automatic download of the ENC firmware is in progress. Even when the Ready LED (green) blinks, the subsystem is operational.
No:
4. Does the Warning LED (orange) blink at high speed?
Yes: Wait until the Warning LED (orange) on the base unit is off, and the Ready LED (green) on the base unit lights because the update of the flash program is executed.
No: Go to step 5.
5. Turn off the Power switch.
6. After waiting for more than one minute, turn on the Power switch.

7. After 4 minutes, does the ready LED on the base unit go on?
Yes: Continue to use the equipment in its current operational state. If the Ready LED (green) blinks at high speed, downloading of the ENC firmware is in progress. Even when the Ready LED (green) blinks, the array is operational. And go to step 10.
No: go to step 9.
8. Set the main switch to Off.
9. Contact Technical Support. See [Getting help](#) in the Preface of this manual.
10. End of procedure.

Alarm LED has turned on

1. Identify the components in which a failure occurs.
2. Replace the failed components. See the *Hitachi AMS 2000 Family Storage System Service Guide* for instructions.

Warning LED has turned on or blinks

1. Does the WARNING LED (orange) blink at high speed?
Yes: Wait until the WARNING LED (orange) on the base unit is off, and the READY LED (green) on the base unit lights because the firmware is being updated.
No: Go to step 2.
2. Does the WARNING LED on the base unit blink at low speed?
Yes: Use Navigator 2 to identify the failure in the base unit, then go to step 6.
No: Go to step 5.
3. Is the READY LED on the base unit on?
Yes: Go to step 5.
No: Refer to (3) READY LED does not turn on or READY LED has turned on once and then turn off off.
4. Identify in which components a failure resides in the base unit.
5. Continue to use the equipment and contact Hitachi Data Systems Technical Support. See [Getting help](#) at the beginning of this chapter.
6. End of procedure.

Upgrading the hardware

This chapter describes procedures for adding optional components and additional units to a Hitachi AMS 2100/2300 Storage System. It includes the following key topics:

- ❑ [Prerequisites](#)
- ❑ [Adding a disk drive](#)
- ❑ [Recognizing a new logical unit](#)
- ❑ [Adding an expansion unit](#)

Prerequisites

Please read this entire section before beginning any work on an array.

In addition to these prerequisites, also see the safety instructions at the beginning of [Chapter 5, Installation](#).



CAUTION! Back up your data before adding or replacing hardware components. If a part is installed incorrectly, it may be possible that data can be lost. Hitachi Data Systems strongly recommends that you back up your data to a remote array before beginning hardware upgrades or replacements.



CAUTION! When adding or replacing a disk drive with the array power on, be sure to complete the installation within ten minutes after removing the dummy disk drive. An open slot in the array can let enough cooling air out of the array that after ten minutes, it can overheat and shut down.

Before adding or replacing any hardware components in either the base unit or the expansion unit, protect your data from accidental loss. The following paragraphs provide important information that can help protect your array from accidental loss of data.

1. The procedure to add an optional component varies depending on the component being added and the location where the component is to be installed.
2. **Before adding, removing, or replacing a part, read the entire procedure.** If you have any questions about the procedure, please call Hitachi Data Systems Technical Support before starting the procedure. It is a lot easier, faster, and less costly than fixing something afterward.
3. Determine whether the work must be done with the array power on or off.
 - The power on condition refers only to the array power and does not consider whether the host power is turned on or off.
 - The power off condition refers only to the array power and does not consider whether the host power is turned on or off.
4. When adding an optional component, change the settings of the array using a management console connected via a LAN. Perform the following before starting the addition of an optional component.
 - Set up a management console on which Navigator 2 is installed.
 - Determine whether the array is operable via a LAN.
5. **Ready LED Status.** Do not add or replace any hardware components while the green Ready LED on the front of the base unit is blinking at high speed. When it is blinking at high-speed, the firmware is being downloaded. Depending on the LAN connection and traffic on the LAN, this could take from 30 to 50 minutes. Wait at least 30 seconds after the Ready LED lights steadily before making any changes to the hardware.

6. **Warning LED Status.** Do not add or replace any hardware components while the orange Warning LED on the front of the base unit is blinking at high speed. When it is blinking at high-speed, the ENC firmware is being updated (flashed). This could take from 30 to 85 minutes. Wait at least 30 seconds after the Warning LED goes out and the Ready LED lights steadily before making any changes to the hardware.
7. If you remove a SAS self-encrypting drives (SED) from an array, a Data At Rest Encryption feature locks the drive, completely preventing access to its contents. Data cannot be accessed until the drive is placed back into the original array by IT administration and unlocked. If the drive is installed in a different array, the drive becomes unusable and requires intervention by Technical Support. To avoid this situation, always check that you are installing the correct SAS (SED) drive into the appropriate array.

Adding a disk drive

Before beginning the procedure to add or remove a disk drive, ensure the prerequisites on the previous page have been met.

Locations and numbers of disk drives

As shown in [Figure 9-1](#), the disk drive numbering in an array is #0 to #14 from the left to right viewed from the front of the array. The same numbering applies to both the base unit and the expansion unit.



NOTE: Disk drive slots use the same numbers whether they contain a drive or not.

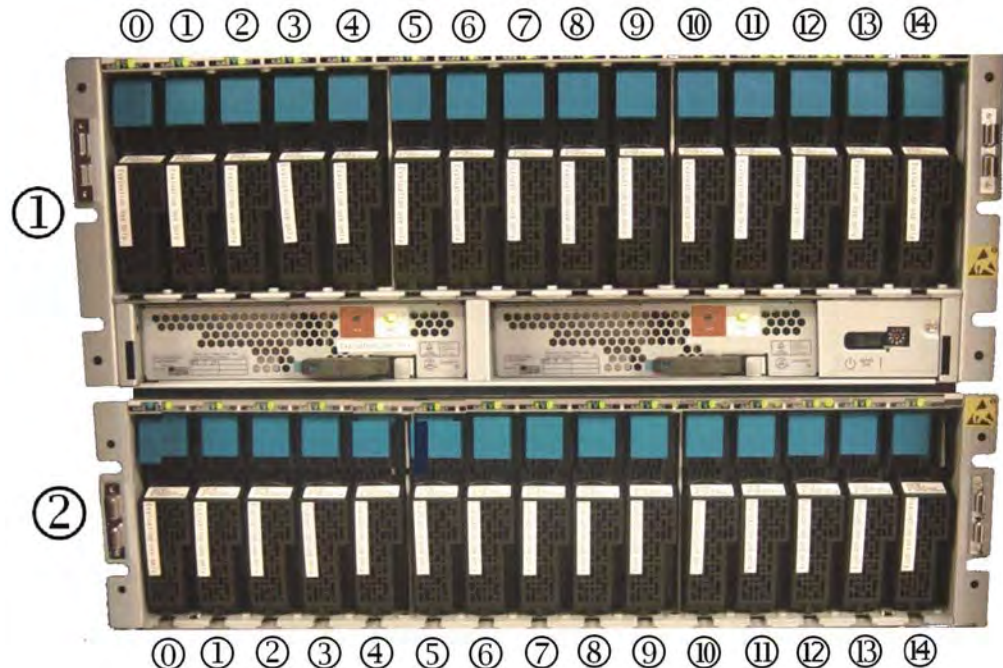

Figure 9-1: Base and Expansion Unit Disk Drive Numbering

Table 9-1: Base and Expansion Unit Disk Drive Numbering

Item	Description	Item	Description
①	Base Unit	②	Expansion Unit

Locations of disk drives

The locations and numbers of disk drives are shown below in [Figure 9-2](#)

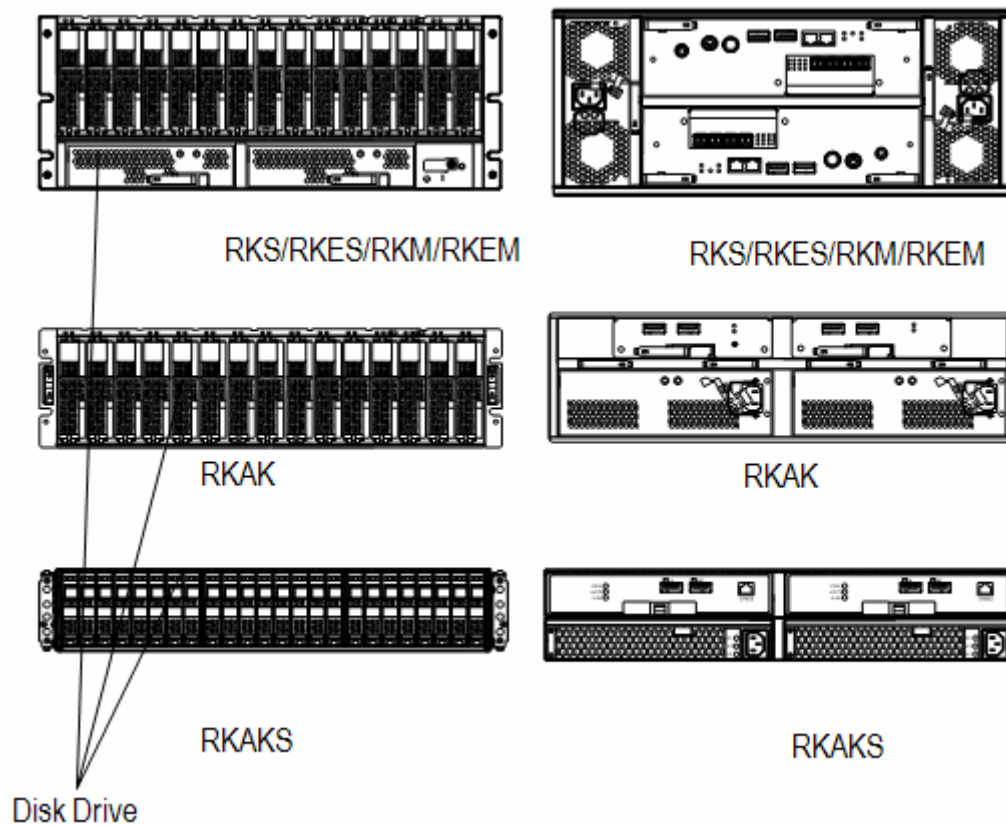

Figure 9-2: Locations of disk drives

If no vacant slots are available

If you need to add more drives to the array than there are vacant slots, add an additional expansion unit. See [Adding an expansion unit on page 9-9](#) for instructions to do this.



NOTE:

- The minimum number of drives in each base unit is four. They must be installed in slots 0-3. The first four drives must all be the same type drive (SAS or SATA).
- The minimum number of drives that must be installed in an expansion units is two. These two drives must both be either SATA or SAS drives.
- After the minimum configuration is met, you can add two SAS or two SATA drives (which makes a RAID 1 configuration), or other combinations of drives as required to meet the RAID configurations specified in Chapter 1.

Installation procedure

Complete the following steps to install a disk drive. Do not skip any steps.



CAUTION! disk drives are a precision machines. Be careful not to drop a disk drive or allow it to receive a mechanical shock or vibration.



Static-sensitive. Ground yourself before touching. Before unpacking or handling disk drives and other static-sensitive components, wear a wrist strap and connect it to an unpainted part of the array chassis. When you insert a disk drive into the array, hold the disk drive with the hand on which you are wearing the wrist strap.

When you install a disk drive or other component in the array, support its frame with your hand that has the wrist strap on it. You can discharge static electricity by touching the metal plate. See [Figure 9-3](#).

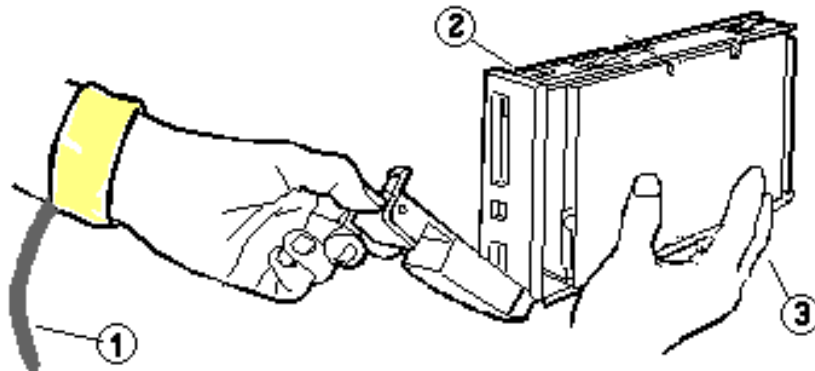

Figure 9-3: Installing a Disk Drive

Table 9-2: Installing a Disk Drive

Item	Description	Item	Description	Item	Description
①	Wrist Strap	②	Disk Drive	③	Touching the metal frame of the disk drive

1. Remove the front bezel. Grasp the front bezel at both upper corners and pull out and down. When the bezel is free of the catches at both ends, lift the bezel up and away from the unit. Put it aside. You will reinstall it at the end of this procedure.



NOTE: If you are installing multiple drives, remove only one drive filler at a time and install a drive in the slot before removing the next drive filler.

2. If you have not already done so, put on an antistatic wrist strap. See the Prerequisites in this chapter for further information.
3. Unpack the new disk drive and put the drive on an antistatic mat.



CAUTION! Time Limit between steps.
Complete step 5 within 10 minutes after completing step 4. It is possible for the unit to overheat and shut down if enough cooling air is allowed to escape from the open drive slot.

4. Loosen the mounting screws and remove the filler (“dummy disk drive”) from the slot where you want to install the new drive. You may note that cooling air is coming out of the open slot.
5. Unlock the lock lever on the new drive, as shown in [Figure 9-4](#).

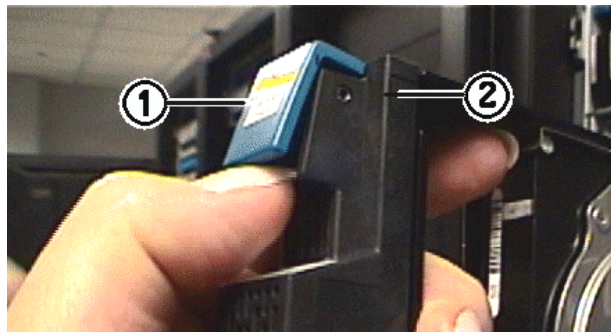

Figure 9-4: Unlocking the Lock Lever

Table 9-3: Unlocking the Lock Lever

Item	Description	Item	Description
①	Lock Tab	②	Lock Lever

6. Gently slide the new disk drive in the open slot in the expansion unit.
7. Gently slide the drive into the slot line the lock tab up with the slot up with the hole in the chassis.
8. Close the lock lever. As you do this, the disk drive is pulled into the chassis and the electrical connector is plugged into the socket.
9. Make sure that the disk drive is fully inserted and that the lock lever “clicks” when fully closed.
10. Verify that the drive begins to run (spins up) as soon as it is fully inserted into the slot and is connected electrically to the unit.

If the drive is a replacement for a failed drive, as soon as the drive is operational, the system will begin copying data to it. The system copy is completed in approximately 1 minute 30 seconds for each disk drive.

11. Repeat steps 3 through 10 for each disk drive that you are installing.
12. When you have installed all the drives, replace the front bezel. Grasp the bezel at both sides engage the hooks at the bottom of the bezel with the lower edge of the unit chassis. Then rotate the top of the bezel inward and press in at the vertical center of both ends of the bezel to engage the catches.

Expanding storage capacity

To expand the storage capacity of an array with the power off, repeat steps 1 and 2 below for each disk drive that you add to the array.

1. Remove the dummy disk drive. Press the round dent on the latch to unlock it and then open the latch. Pull outward on the latch to remove the dummy disk drive from the base or expansion unit. Store the dummy drive so that it can be used to replace a disk drive if you remove one.
2. Install the disk drive to be added, taking care not to apply any shock to it.
 - a. Fit the disk drive in the guide rail of the chassis and slide it in the direction shown by the arrow.
 - b. Push it in until it reaches the position where the tab on the bottom of the lock lever on of the handle can be entered into the rectangular hole at the lower part of a frame on the front side of the unit.
 - c. Push the lock lever inward until the lock button clicks.



NOTE: If the lock lever is closed or nearly closed when you slide the disk into the slot, the tab on the bottom will catch on the front of the unit and cannot be inserted into the slot in the chassis. Be sure the lock lever is open far enough when you slide the disk in so that the tab can be inserted into the slot.



NOTE: When the disk drive has been added while the array power is on, the Alarm LED on the disk drive will go out a few minutes after the disk drive has been inserted. Make sure that the LED goes out.

Recognizing a new logical unit

The following example shows how to make a host computer that is running HP-UX recognize a Logical Unit while the array power is on. As shown in the following illustration, the management PC on which Navigator 2 is installed is connected to the array via a LAN cable.

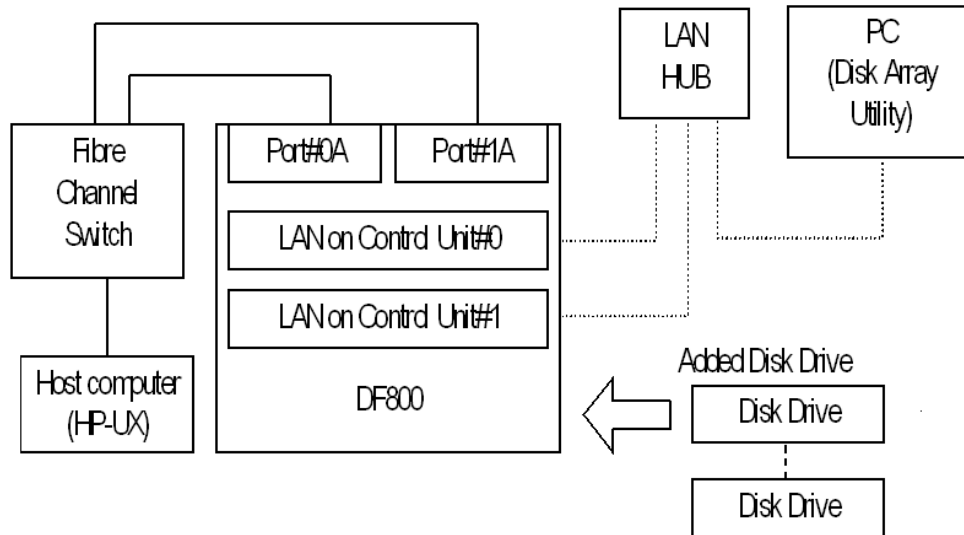

Complete the following steps to make the host computer recognize a newly created logical unit.

1. Make sure that the host computer and the DF800 are in the Ready status. (I/Os host computer can be continued.)
2. Install the disk drives to be added in the DF800.
3. Create a new RAID group for the installed disk drives.
4. Create one or more new logical units for the RAID group.
5. Format the logical units.
6. From the host, issue the Fibre Channel disk command **ioscan -n** to verify that the array has been recognized by the host computer. However, the status of the newly added logical unit is displayed as NO-NW.
7. Issue the **insf -e** command from the host to create a device file of the logical unit(s) which have just been added.
8. From the host, issue the Fibre Channel disk command **ioscan -n** to verify that the array has been recognized by the host computer. The status of the newly added logic unit is displayed as CLAIMED.
9. Create a file system by creating the volume group and logical volume for the newly added logical unit from the host computer.

Logical units created according to the above procedure are usable by the host computer.

Adding an expansion unit

Prerequisites

Before starting the addition, ensure that the following requirements are met. If not, an abnormal termination of the addition or a system down may be caused.

- Ensure that the expansion unit being added has two power supplies and two ENC units installed.
- Ensure that no alarm or warning LEDs are on or blinking anywhere in the array. You can add an expansion unit only when the Warning and Alarm LEDs on the array are off and the Power LED (green) and Ready LED (green) light up.
- Do not perform the recognition (*1) operation of the expansion unit during the execution of the format command (it is not the LU format from Navigator 2 from the host computer. When the format was executed from the host computer, add the expansion unit after the format is completed.
- Do not add any components while the Ready LED on the front of the base unit is blinking at high speed. When it is blinking at high-speed, the ENC firmware is being downloaded. Add components only after ensuring that the READY LED on the front of the base unit is ON. This can take from 30 to 50 minutes.
- Do not add any components to a unit while the Warning LED on the front of the base unit is blinking at high speed. The Warning LED blinks at high speed while the firmware is being updated. Ensure that the Warning LED on the front of the base unit is OFF and the Ready LED is ON. This can take a maximum of 30 to 85 minutes.

Restrictions

Observe the following restrictions strictly. The system and/or the expansion unit may shut down if these restriction are not followed.

- Do not replace any parts in the storage system while the expansion unit. is being connected to the AMS 2100/2300.
- Do not replace any parts in the storage system while the control unit in the AMS 2100/2300 is recognizing the expansion unit.

Specifications

- Connect at least one ENC cable per ENC Unit to the AMS 2100/2300 or to another expansion unit.
- The number of expansion units must not exceed the maximum number of expansion units allowed for the model of the base unit. The expansion unit of:
 - An AMS 2100 can have a maximum of seven expansion units.
 - An AMS 2300 can have a maximum of 15 expansion units.
- If a failure occurs in the newly added expansion unit on the AMS 2100/2300 during the connection and recognition process, troubleshoot and repair the base unit first, and then repair the expansion unit.

- When adding an expansion unit with the array power turned off:
 - a. Install all the disk drives to be added in the expansion unit.
 - b. Connect the ENC cables between the expansion units and the base unit and other expansion units.
 - c. Turn on the power. See [Adding an expansion unit with the array power turned off on page 9-11](#).
- Do not add any optional parts while the system is booting up. Before adding any parts, ensure that there are no Warning or Alarm LEDs on anywhere in the system, and wait until after the Ready LED on the base unit is ON before adding any parts.

Adding an expansion unit

You can add an expansion unit with the array power turned ON or turned OFF, but the procedures are different. See the following procedures, depending on the status of the array.

Table 9-4: Procedures for Adding an Expansion Unit

Array Power	Procedure to Use
ON	Procedure for adding the expansion unit with the array power turned on"
OFF	Procedure for adding the expansion unit in the status that the array power is turned off"

Adding an expansion unit with the array power turned on

Complete the following steps to add an expansion unit with the array power turned on.

1. Install a set of appropriate rails in the rack in which you plan to install the expansion unit.
2. Unpack the expansion unit.
3. Install the expansion unit in the rack.
4. If the disk drives are not already installed in the expansion unit, remove the expansion unit front bezel, install the disk drives, and replace the front bezel.



NOTE:

- The minimum number of drives that must be installed in an expansion units is two. These two drives must both be either SATA or SAS drives.
- After the minimum configuration is met, you can add two SAS or two SATA drives (which makes a RAID 1 configuration), or other combinations of drives as required to meet the RAID configurations specified in Chapter 1.

-
5. Connect the ENC cables from the expansion unit to the base unit or to another expansion unit. See the instructions and connection diagram in [Connecting ENC cables \(expansion unit\) on page 5-36](#).

6. Connect the power cables to the expansion unit. After the expansion unit and its components have completed their POSTs, the Ready LEDs are on, and no Alarm LEDs are on, the base unit begins the process of recognizing the expansion unit.
 - If the base unit does not correctly connect to or recognize the expansion unit, see the instructions in [Connection and recognition of the expansion unit on page 9-12](#).
 - If the base unit correctly recognizes the expansion unit, use Navigator 2 to set up the following, as needed. See [Configuration roadmap on page 7-9](#) for links to the appropriate procedures.
 - System parameters
 - RAID groups
 - Formatting the logical units
 - Setting spare disk drives and active mode
 - LUN mapping
 - Storage Features

Adding an expansion unit with the array power turned off

Complete the following steps to add an expansion unit with the array power turned on.

1. Ensure that the data in the cache is not being backed up. If a disk drive is added without canceling the backup, user data may be lost.
2. Install a set of appropriate rails in the rack in which you plan to install the expansion unit.
3. Unpack the expansion unit.
4. Install the expansion unit in the rack.
5. If the disk drives are not already installed in the expansion unit, remove the expansion unit front bezel, install the disk drives, and replace the front bezel.



NOTE:

- The minimum number of drives that must be installed in an expansion unit is two. These two drives must both be either SATA or SAS drives.
- After the minimum configuration is met, you can add two SAS or two SATA drives (which makes a RAID 1 configuration), or other combinations of drives as required to meet the RAID configurations specified in Chapter 1.

-
6. Connect the ENC cables from the expansion unit to the base unit or to another expansion unit. See the instructions and connection diagram in [Connecting ENC cables \(expansion unit\) on page 5-36](#).
 7. Connect the power cables to the expansion unit.
 8. Turn the array power on (base unit Power switch) and wait for the system to boot. After the base and expansion units and their components have completed their POSTs and the Ready LEDs are on, the base unit begins the process of recognizing the new expansion unit.

- If the base unit does not correctly recognize the expansion unit, see [Connection and recognition of the expansion unit](#) below.
- If the base unit correctly recognizes the expansion unit, use Navigator 2 to set up the following, as needed:
 - System parameters
 - RAID groups
 - Formatting the logical units
 - Setting spare disk drives and active mode
 - LUN mapping
 - Storage Features

See [Configuration roadmap on page 7-9](#) for links to the appropriate procedures.

Connection and recognition of the expansion unit

Follow the instructions and screenshots in this section to Use Navigator 2 to perform the connection and recognition of the expansion unit. When the procedure is complete, the expansion unit becomes part of the array to which it is connected.

1. Check the items in the following checklist before connecting and recognizing the expansion unit.

Table 9-5: Troubleshooting Procedure

	Unit	Item to be checked	Actions to correct the problem
1	ENC Unit	Two ENC units are installed in the expansion unit	Ensure that two ENC units are installed.
2	Power Unit	Two power supplies are installed in the expansion unit	Ensure that two power supplies are installed.
3	Base unit Warning LED	The Warning LED on the front of the base unit is not blinking or ON.	Ensure that the Warning LED on the front of the base unit has turned off.
4	Base unit Ready LED	The Ready LED on the front of the base unit should light up.	<ul style="list-style-type: none"> • If the ENC firmware is being downloaded, check that the Warning LED on the front of the base unit turns off within 30 to 50 minutes and the Ready LED is ON. • Ensure that the Ready LED on the front of the base unit is ON. If the READY LED on the front of the base unit continues blinking and does not go ON, contact Hitachi Data Systems Technical Support.

2. Start Navigator 2.
3. In the Array List window, select the array to be added.

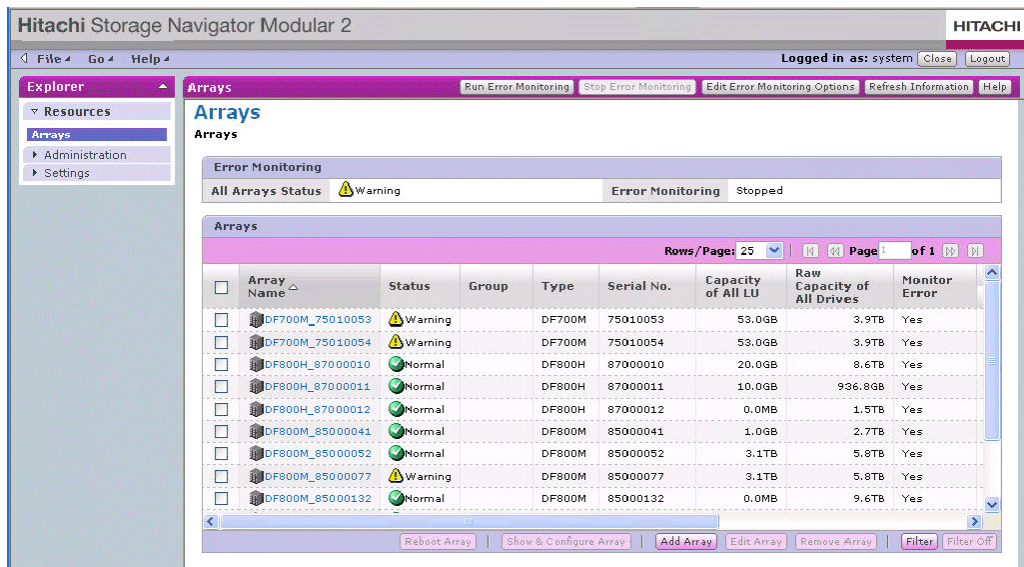

- The Array Properties window is displayed. Expand the tree in the Explorer tree and select Components > **Trays**. The **Trays** window is displayed.
- In the Trays window, click **Install Tray**.

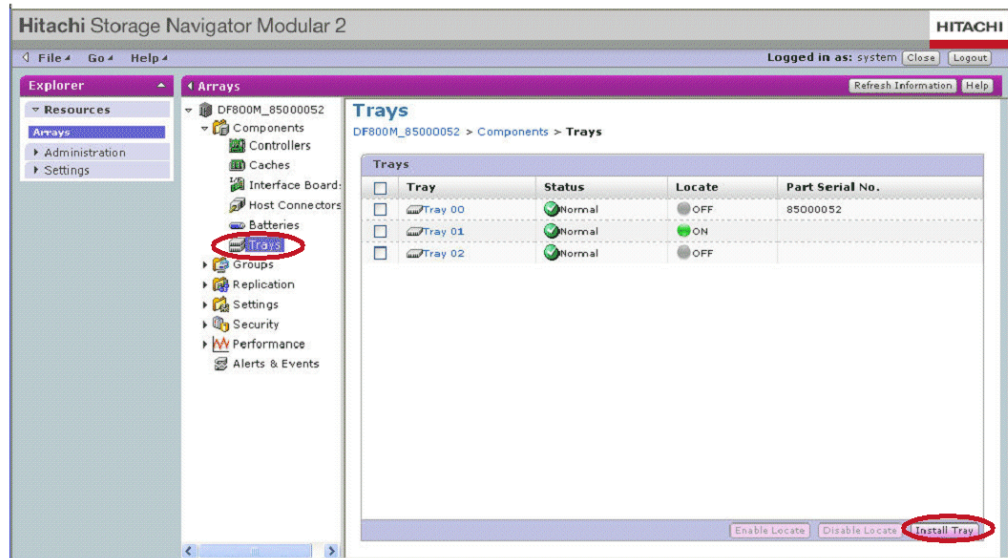

6. Complete steps 1 - 3 in the Navigator 2 Add Trays window. The expansion unit may be connected to the base unit or to another expansion unit.
 - a. Complete the instructions in the following window when connecting an expansion unit to a base unit.

HSNM2
HITACHI

Install Tray

Help

Install Tray

LOC LED of only the tray that you connect install tray is on. Install tray in reference to below procedure.

Step1: Connecting ENC Cable (In reference to figure, connect tray with LOC LED lighting)

- a) Connect Controller0's PATH0 of tray with LOC LED lighting and ENC 0's IN of install tray.
- b) Connect Controller1's PATH0 of tray with LOC LED lighting and ENC 1's IN of install tray.

Step2: Connecting Power Cable

Connect Power Unit 0 and 1 of installing tray and PDB.
(Plug in the receptacles of the PDB on the other side to duplicate.)

Step3: Start of installing tray

Click OK to start installing tray process.

Rear View of Array

OK
Cancel

- b. Complete the instructions in the following window when connecting an expansion unit to another expansion unit.

HSNM2
HITACHI

Install Tray

Help

Install Tray

LOC LED of only the tray that you connect install tray is on. Install tray in reference to below procedure.

Step1: Connecting ENC Cable (In reference to figure, connect tray with LOC LED lighting)

- a) Connect ENC0's OUT of tray with LOC LED lighting and ENC 0's IN of install tray.
- b) Connect ENC1's OUT of tray with LOC LED lighting and ENC 1's IN of install tray.

Step2: Connecting Power Cable

Connect Power Unit 0 and 1 of installing tray and PDB.
(Plug in the receptacles of the PDB on the other side to duplicate.)

Step3: Start of installing tray

Click OK to start installing tray process.

Rear View of Array

OK
Cancel

NOTE:

- If you were unable to check the **Addition Completed** window because you closed the dialog while adding the expansion unit, wait for about three minutes and display the **Trays** window again in Navigator 2. Follow steps 2 - 4 in the Trays window.
- If the chassis being added is displayed, the addition is completed. If it is not displayed, remove the cables connected at the time of the addition and add the chassis again.
- If you connect the power cables to the Power Unit of the added expansion unit, the Alarm LED on the ENC Unit turns ON. This is normal and is not an error. The LED will turn OFF when the addition is complete.
- If you click **Cancel** in the **Install Tray** window while the expansion unit is being added, the window closes but the Locate (LOC) LED stays on. To turn off the Locate LED:
 - a. In the Trays window, click **Refresh Information** to update the window.
 - b. Select the tray in which the position column is displayed as ON, and click **Disable Locate**. The Locate LED should turn off.

-
7. The following window is displayed while the expansion array is being added.

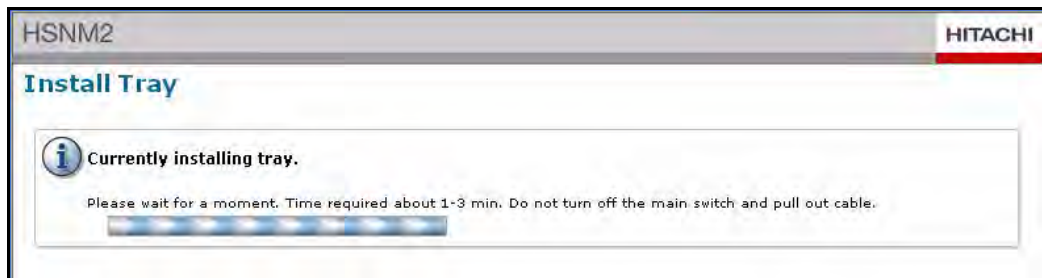

8. When the addition is complete, the following window is displayed.



To install another expansion unit, click **Install Next Tray** and go to step 6. If you do not want to install another expansion unit, click **Finish**.

9. If the connection and recognition of the expansion unit fails, the following window is displayed.

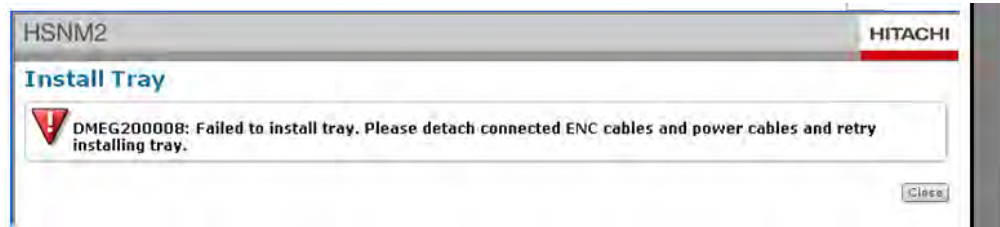

10. If the connection and recognition of the expansion unit fails:
 - a. Click **Close** to close the window.
 - b. Disconnect the power cables from the expansion unit.
 - c. Disconnect the ENC cables from the expansion unit.
 - d. Start from step 6 again.
11. If you stop the addition of an expansion unit , the Locate LED stays ON. To turn off the Locate LED:
 - a. In the **Trays** window, click **Refresh Information** to update the window.
 - b. Select the tray on which the position column is displayed as ON, and click **Disable Locate**.
12. Check the **Trays** window and ensure that the added expansion unit is listed there.

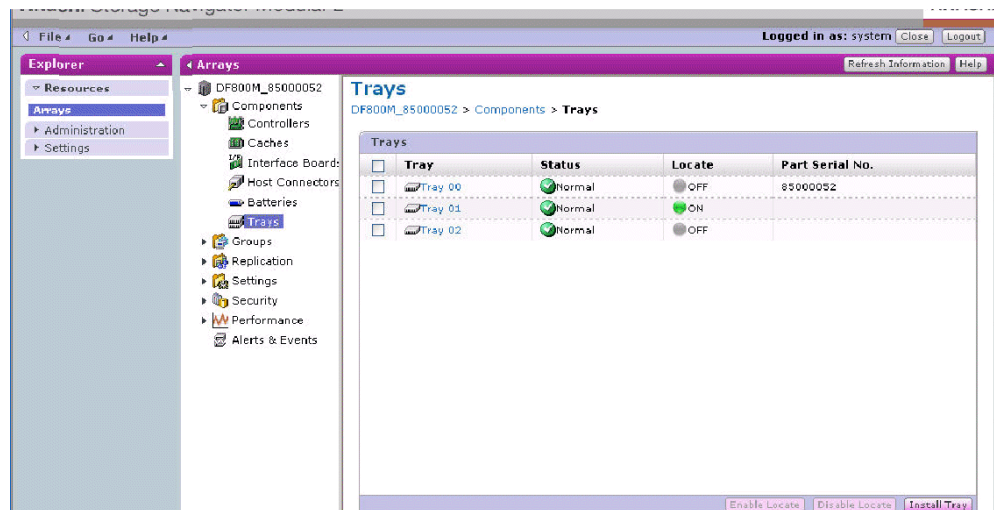

Upgrading the firmware

The AMS 2100/2300 can use newer versions of its firmware as they become available. This chapter describes how to upgrade the firmware on an AMS 2100/2300 storage array. This procedure requires the use of the Upgrade Firmware wizard in the Navigator 2 storage management software.

This chapter includes the following key topics:

- [Overview](#)
- [Prerequisites](#)
- [Upgrading the firmware](#)
- [Upgrading the software](#)

Overview

The instructions in this chapter assume that the AMS 2100/2300 system is operating normally.

The procedure to upgrade the firmware on an AMS 2100/2300 includes using the Upgrade Firmware wizard that is part of the Navigator 2 storage management software. See [Chapter 7, Configuration](#) for basic information on using the Navigator 2 software. See the Navigator 2 online help system for detailed information. To access the help system, click **Help** in any window in Navigator 2.

While the firmware is being upgraded, the host I/O may be focused in one of the two control units. Therefore, Hitachi Data Systems recommends that this work be performed during a period when the host I/O load is low.

Prerequisites

- Ensure that there is a good LAN connection between the AMS 2100/2300 and the host computer, whether they are connected directly or connected via switch.
- Ensure that other applications such as JP1/HiCommand Device Manager, or other Hitachi applications are not currently accessing the AMS 2100/2300, either directly or via the LAN.
- Ensure that all hardware components of the array are working and that no parts have been removed.

Upgrading the firmware

Use the following procedure to upgrade the firmware.



CAUTION! Do not remove or replace any hardware components in the array while the firmware is being downloaded or installed. Wait at least 30 seconds after download and/or installation is completed before beginning any hardware replacement procedures.

1. Download the latest firmware from the Hitachi Data Systems Support Portal. See the [Getting help](#) section in the Preface for information about accessing the support portal.
2. Launch a web browser and log in to Navigator 2 at the following URL:
`http://<IP address of management console PC>:23015/StorageNavigatorModular`
If needed, see [Chapter 7, Configuration](#) for information on starting and using Navigator 2.
3. Log in to Navigator 2. After a few seconds, the Navigator 2 Array List window is displayed. The table in the window displays the names and descriptions of the arrays currently listed in the Navigator 2 database.

- As shown in the following illustration, in the Array List window, either click the name of the array whose firmware you want to update, or click the checkbox and then click **Show and Configure Array**.

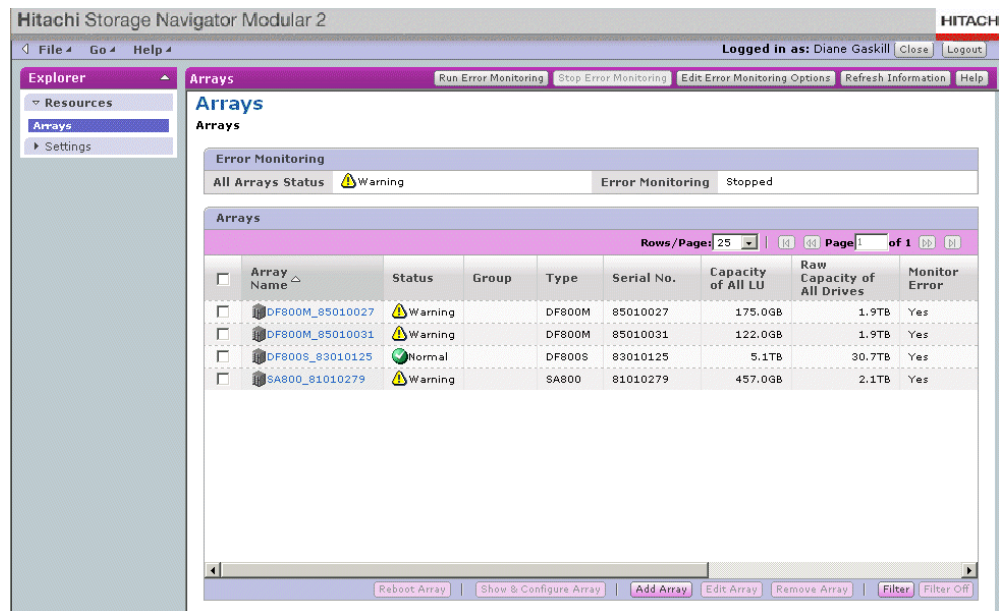

- The Array Window (shown below) is displayed. In the Common Array Tasks section of the Array window, click **Update Firmware**. This launches the Upgrade Firmware wizard. The wizard contains step-by-step instructions to upgrade the firmware on the AMS 2100/2300.



For detailed instructions and further information, see the help page in the Navigator 2 online help system. Click **Help** on any screen in the wizard to access the help for the wizard.

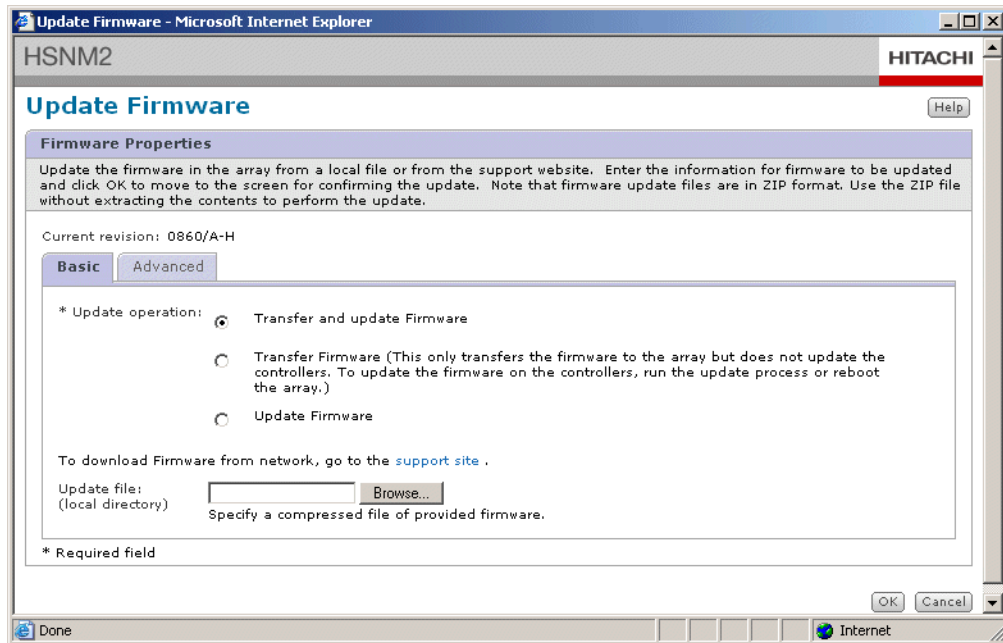

6. Select one of the three following options:
 - Transfer and update Firmware - this option downloads the firmware from the Support portal and installs the firmware on the control unit.
 - Transfer Firmware - this option downloads the firmware to the array but does not install it. To update the firmware on the controllers, run the update process or reboot the array.
 - Update Firmware - this option installs firmware that has already been downloaded but not installed.
7. OPTIONAL :Click the **Advanced** tab. the following screen is displayed.

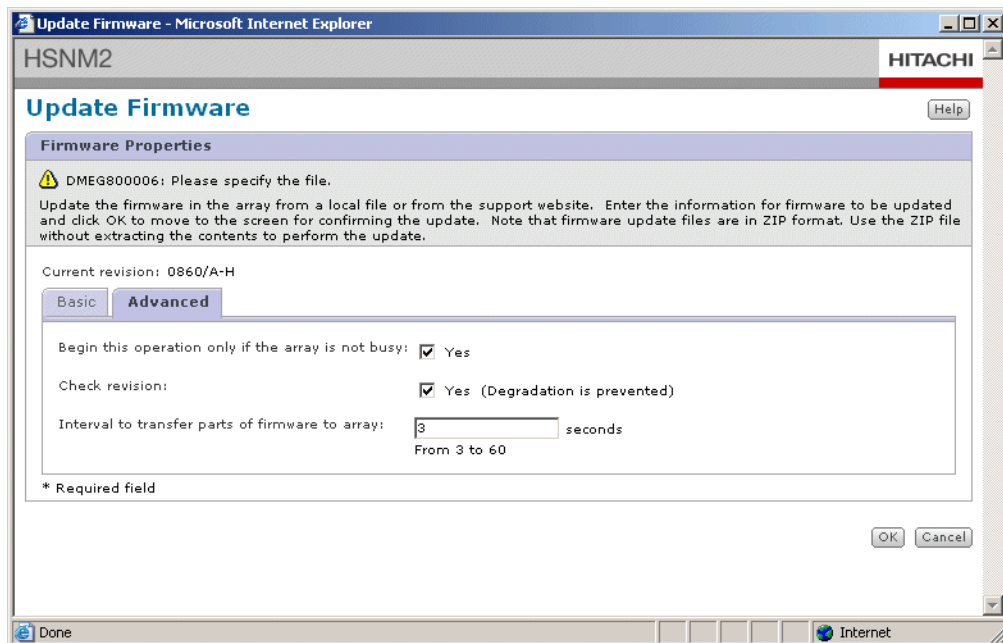

8. Review the default settings and change as needed.

9. To return to the Basic tab, click **Basic**. Make any changes to the settings as needed. Otherwise click **OK**. (Skip to step 12.)
10. Next to **Update file**, click **Browse**. Then navigate to the location where the firmware file resides, click the file, and click the **Open** button. The path and filename appear in the **Browse** field.
11. In the Update Firmware dialog box, click **OK**. The following confirmation window appears:

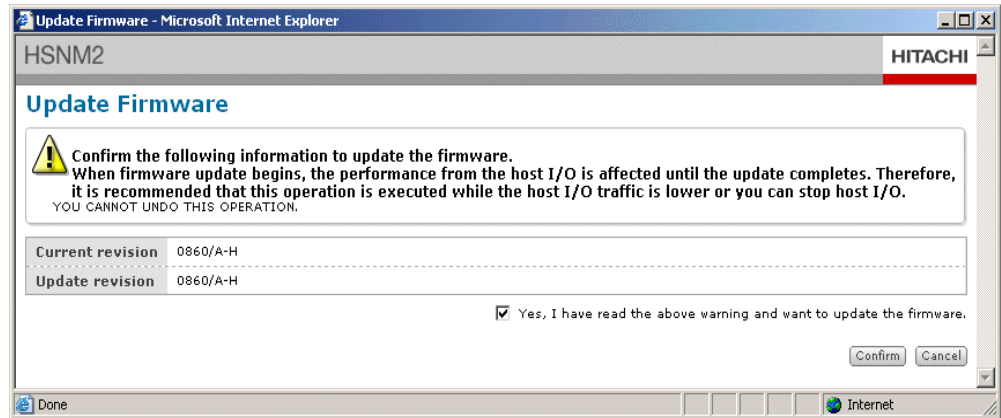

12. Read the information in the window. Then click the checkbox **Yes, I have read the above warning and agree to update the firmware**.
13. Click the **Confirm** button to proceed. A window similar to the following appears as the firmware is updated. The window shows the approximate time required to update the firmware.

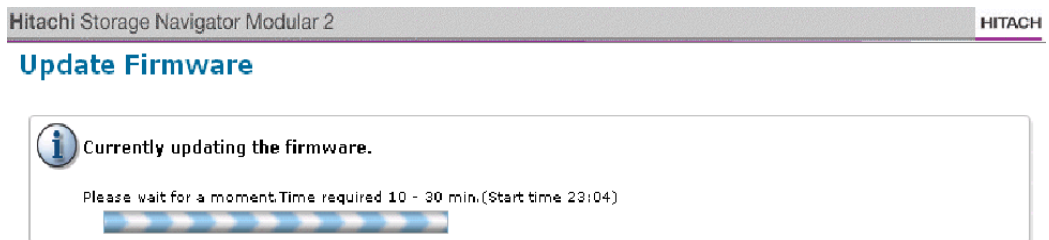

CAUTION! Do not cancel the upgrade procedure or have the AMS 2100/2300 perform I/O operations while the firmware is being upgraded.

14. After the firmware has been updated, a message informs you that the operation has been completed successfully. Click **Close** to confirm the message and close the message box. The array can then return to normal operation.

Upgrading the software

The instructions to upgrade the storage management software (Hitachi Storage navigator Modular 2) are located in [Chapter 7, Configuration](#).

Connection configuration restrictions

This chapter describes how to connect additional chassis.

- [Connection of Additional Chassis](#)

Connection of Additional Chassis

Additional chassis must be connected in order of the path number (Path #0 to Path #1) and Unit ID number (starting with Unit ID 0 at the bottom of the rack). Path #0 to Path #1 must be populated before proceeding to the next Unit ID levels.

The following figures show correct and incorrect configurations.

Correct installation

The following figure shows [1], [2] and [3] connected from left to right in the order shown by the arrow to keep the path connection from bottom to top in numerical order.

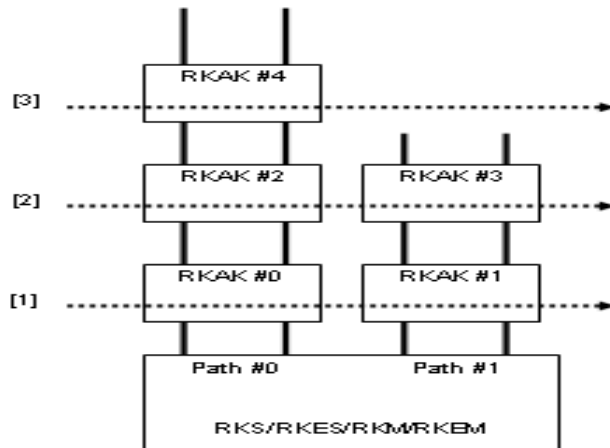

Figure 11-1: Correct Installation - Connecting the RKS/RKES/RKM/RKEM and RKAK

Incorrect installation

The following figure is not correct because it shows Path #0 in the [3] row is skipped, and Path #1 is connected.

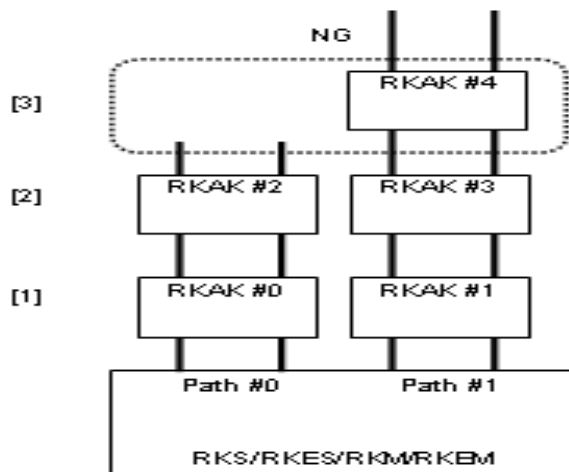

Figure 11-2: Incorrect Installation - Connecting RKS/RKES/RKM/RKEM and RKAK

The following figure is another example that is not correct because it shows Path #1 in the [3] row is skipped, and Path #0 in the [4] row is connected.

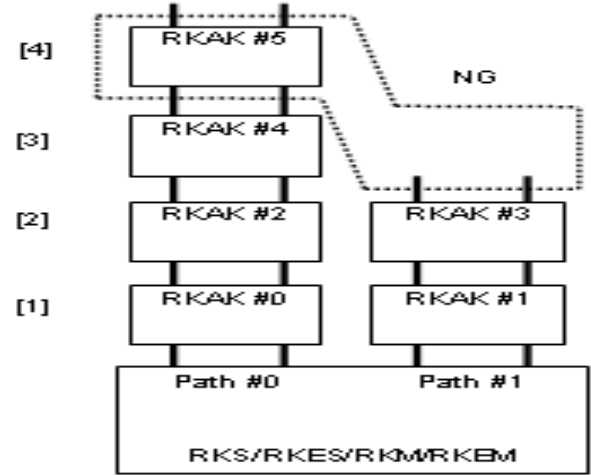

Figure 11-3: Incorrect Installation - Connecting RKS/RKES/RKM/RKEM

Specifications

This appendix includes a comprehensive set of specifications for the AMS 2100/2300 described in this manual. It includes the following key topics:

- [Mechanical specifications](#)
- [Electrical specifications](#)
- [Environmental specifications](#)
- [Ethernet specifications](#)
- [Cache specifications](#)

Mechanical specifications

Table A-2 describes the mechanical specifications for the AMS 2100/2300.

Table A-1: AMS 2100/2300 Mechanical Specifications

Dimension	Size (English, metric)		
	Base Unit (AMS 2100/ AMS 2300 (RKS/RKM))	Expansion Unit (RKAK)	High-density Expansion Unit (RKAKX)
Height	6.9 inches (174 mm) / 4U	5.1 inches (129 mm) / 3U	6.93 inches (176 mm) / 4U
Width	19 inches (483 mm)	19 inches (483 mm)	19 inches (483 mm)
Depth	25.6 inches (649 mm)	25.6 inches (649 mm)	33 inches (840 mm)
Weight	112 Lbs (51 Kg)	88 Lbs (40 Kg)	178 Lbs (81 Kg)

**Table A-2: AMS 2100/2300 (RKAKS)
Mechanical Specifications**

Dimension	Size (English, metric)
	Expansion Unit (RKAKS)
Height	3.39 inches (86.2 mm) / 2U
Width	18.93 inches (480.8 mm)
Depth	20.79 inches (528.1 mm)
Weight	50.7 Lbs > (23 Kg)

Electrical specifications

Table A-3 describes the electrical specifications for the AMS 2100/2300.

Table A-3: AMS 2100/2300 Electrical Specifications

Item		Base Unit (AMS 2100/AMS 2300 (RKS/ RKM))	Expansion Unit (RKAK or RKAKS)	High-density Expansion Unit (RKAKX)
Volts AC		100/200 (100 to 120/200 to 240)		
Frequency (Hz)		50/60 +/- 1		
Number of Phases, Cabling		Single phase plus ground (3 wire)		
Steady-state Current (amps)		3.8 x 2 /1.9 x 2	2.4 x 2 /1.2 x 2	3.7 x 4/1.9 x 4
Breaking Current (A)		16.0	16.0	16.0
Heat Value (kJ/h)		2,670 or less	1,660 or less	5,190 or less
Required Power ¹	Steady State Current (VA/W) ^{2 3}	760/740 or less	480 /460 or less	1,480 /1,440 or less
	Starting state (VA/W)	760/740 or less	480 /460 or less	1,480 /1,440 or less
Electrical Insulation Performance	Insulation Withstands Voltage	AC 1,500 V (10 mA, 1 min)		
	Insulation Resistance	DC 500 V, 10 MΩ or more		

1. Power requirement in the case of the maximum configuration is shown. When planning facilities such as the uninterruptible power supply (UPS), specify the power factor as 100% for calculation. Value at 100 V/200 V is shown.

(Example: 300 W=300 VA)

The actual required power may exceed the value shown in the table when the tolerance is included.

2. The power current of N x 2 described in this table is required for operation by a single power supply unit.

3. When one of the two power supply units fails, the other power supply provides the total power to the unit that the two supplies together did before the failure. The operating power supply therefore draws the same current as the two supplies did before the failure. To make sure that either power supply can operate in this manner, ensure that the PDUs in the rack can supply twice the normal power of the units plugged into it.

Environmental specifications

Table A-4 describes the environmental specifications for the AMS 2100/2300.

Table A-4: Environmental Specifications

Item	Specification
Temperature, Operating	50° F to 104° F (10° to 40°C)
Temperature, Storage	14° F to 122° F (-10° to 50°C)
Temperature, While Transporting	-22° F to 140° F (-30° to 60°C)
Temperature Change Rate	50° F (10°C) per hour
Humidity, Operating	46° F to 176° F (8° to 80°C)
Humidity, Storage	46° F to 194° F (8° to 90°C)
Maximum Wet Bulb Temperature	84° F (29°C) noncondensing
Vibration, Operating (m/s ²)	2.5 or less (5 to 300 Hz) (within 5 seconds)
Vibration, Storage (m/s ²)	5.0 or less (5 to 300 Hz)
Vibration, While Transporting (m/s ²)	5.0 or less
Impact, Operating (m/s ²)	20 or less (10 ms, half sine wave impact)
Impact, Storage (m/s ²)	50 or less (10 ms, half sine wave impact)
Impact, While Transporting (m/s ²)	80 or less (10 ms, half sine wave impact)
Altitude, Operating	-984.25 to 9842 feet (-300 to 3,000 m)
Altitude, Storage	-300 to 12,000
Acoustic Noise	60 dB (environmental temperature: 32°C or less)

Ethernet specifications

Table A-5 describes the Ethernet specifications for the AMS 2100/2300.

Table A-5: Ethernet Specifications

Parameter	Specification
Works with switches that comply to the following standards:	IEEE 802.1D STP IEEE 802.1w RSTP IEEE 802.3 CSMA/CD IEEE 802.3u Fast Ethernet IEEE 802.3z 1000BaseX IEEE 802.1Q Virtual LANs IEEE 802.3ad Dynamic LACP RFC Channel 768 UDP RFC Channel 783 TFTP RFC Channel 791 IP RFC Channel 793 TCP RFC Channel 1157 SNMP v1 RFC Channel 1213 MIB II RFC Channel 1757 RMON RFC Channel 1901 SNMP v2
Cable Type	RJ-45 1000BASE-TX UTP or STP (STP is recommended)

Cache specifications

The cache specifications are shown in [Table A-6](#).

Table A-6: Cache Specifications

Item	Base Unit
AMS 2100	
Capacity (MB per controller)	2,048, 4,096
Control method	Read LRU / Write After ¹
Battery backup	Provided
Backup duration (h) ²	48 hrs when cache is 8,192 MB (4,096 MB per controller) 72 hrs when cache is 4,096 MB (2,048 MB per controller)
AMS 2300	
Capacity (MB per controller)	4,096, 8,192 MB
Control method	Read LRU / Write After ¹
Battery backup	Provided
Backup duration (h) ²	24 hrs when cache is 16,384 MB (8,192 MB per controller) 36 hrs when cache is 8192 MB (4,096 MB per controller)

1.LRU = Least Recently Used. It is an algorithm where new items are placed at the top of the cache and items at the bottom of the cache are discarded when the cache grows past its size limit. Whenever an item is accessed, it is pulled back to the top of the cache.

2.Backup time in hours with two full charged cache backup batteries.

Regulatory information

This appendix includes a comprehensive set of specifications for the Hitachi AMS 2000 Family Storage System described in this manual. The Regulatory Compliance section includes a table of regulatory specifications that are met by the Hitachi AMS 2000 Family Storage System. Following the table are individual regulatory statements that explain the requirements of various countries. This appendix includes the following topics:

- [Regulatory compliance](#)
- [US FCC Notice and/or Declaration of Conformity](#)
- [Canadian DoC Notice](#)
- [European Declaration of Conformity](#)
- [Notice of export controls](#)
- [China RoHS](#)
- [Disposal](#)
- [Recycling](#)

Regulatory compliance

This equipment has been tested and certificated for the following standards.

Table B-1: Regulatory Compliance

Standard	Specification	Mark on the product	Country
Electronic emission control	FCC Part 15 Subpart B Class A	Yes (FCC)	U.S.A
Radio interference voluntary control	VCCI Class A	Yes (VCCI)	Japan
Limits for harmonic current emissions	JIS C61000-3-2	None	Japan
Electronic emission control	ICES-003 Class A	Yes (ICES-003)	Canada
Electronic emission control	AS/NZS 3548:1995,A1,A2	None	Australia
Electronic emissions certification	EN 50022:1998/A1:2000/A2:2003	Yes (CEmarking)	EU
	EN 61000-3-2:2000/A1:2001/A2:2005		
	EN 61000-3-3:1995/A1:2001		
	EN 55024:1998/A1:2001/A2:2003		
	EN 61000-4-2:1995/A1:1998/A2:2001		
	EN 61000-4-3:2002/A2:2002		
	EN 61000-4-4:1995/A1:2001/A2:2003		
	EN 61000-4-5:1995A1:2001		
	EN 61000-4-6:1996/A1:2001		
	EN 61000-4-8:1993/A1:2001		
EN 61000-4-11:1994/A1:2001			
Electronic emission control	CNS 13438 Class A	Yes (BSMI)	Taiwan
Electronic emission control	KN22	Yes (RRL)	Korea
	KN6100-4		
Safety certification	UL 60950-1	Yes (TUV)	EU/U.S.A
	CAN/CSA-C22.2		
Safety certification	EN 60950-1	Yes (GS)	EU
Safety certification	GOST R60950-2002	Yes (GOST)	Russia
	GOST R51318.22-99		
	GOST R51318.24-99		
	GOST R51317.3.2-99		
	GOST R51317.3.3-99		
Safety certification	IEC 60950-1	Yes(IRAM)	Argentina

US FCC Notice and/or Declaration of Conformity

FCC Notice

Federal Communications Commission

This equipment has been tested and found to comply with the limits for a Class A digital device, pursuant to part 15 of the FCC Rules. These limits are designed to provide reasonable protection against harmful interference when the equipment is operated in a commercial environment.

This equipment generates, uses, and can radiate radio frequency energy and, if not installed and used in accordance with the instruction manual, may cause harmful interference to radio communications. Operation of this equipment in a residential area is likely to cause harmful interference, in which case users will be required to correct the interference at their own expense.

Testing was done with shielded cables. Therefore, in order to comply with the FCC regulations, you must use shielded cables with your installation.

The EMI test was done in the following configuration:

DF800-RKS/RKM+RKAK(4)+RK40

If trouble occurs in another configuration, a user may be requested to take appropriate preventive measures.

Canadian DoC Notice

DOC Notice

Canadian Department of Communications

This digital apparatus does not exceed the Class A limits for radio noise emissions from digital apparatus set out in the Radio Interference Regulation of the Canadian Department of Communications. Operation in a residential area may cause unacceptable interference to radio and TV reception requiring the owner or operator to take whatever steps are necessary to correct the interference.

Cet équipement ne dépasse pas les limites de Classe A d'émission de bruits radioélectriques pour les appareils numériques, telles que prescrites par le Règlement sur le brouillage radioélectrique établi par le Ministère des Communications du Canada. L'exploitation faite en milieu résidentiel peut entraîner le brouillage de réceptions radio et télé, ce qui obligerait le propriétaire ou l'opérateur à prendre les dispositions nécessaires pour en éliminer les causes.

European Declaration of Conformity



Warning This equipment complies with the requirements relating to electromagnetic compatibility, EN 55022 class A for ITE, the essential protection requirement of Council Directive 89/336/EEC on the approximation of the laws of the Member States relating to electromagnetic compatibility.

Notice of export controls

Export of technical data contained in this document may require an export license from the United States government and/or the government of Japan. Contact the Hitachi Legal Department for any export compliance questions.

China RoHS



This symbol is used to display requirements for controlling pollution caused by electronic information products regulation.

Hazardous and toxic substances

Table B-2: Hazardous and Toxic Substances

Toxic and Hazardous Substances and Elements						
Unit	Lead (Pb)	Mercury (Hg)	Cadmium (Cd)	Hexavalent Chromium (Cr(VI))	Polybrominated biphenyls (PBB)	Polybrominated diphenyl ethers (PBDE)
Base Unit	X	○	○	○	○	○
Expansion Unit	X	○	○	○	○	○
The Symbol ○ indicates that this toxic or hazardous substances contained in all of the homogeneous materials for this part is below this limit requirement in SJ/T 11363-2006. The symbol X indicates that this toxic or hazardous substances contained in at least one of the homogeneous materials used for this part is above the limit requirement in SJ/T 11363-2006.						

Disposal

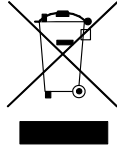

NOTE: This symbol on the product or on its packaging means that your electrical and electronic equipment should be disposed at the end of life separately from household wastes. There are separate collection systems for recycling EU and many cities in the USA. For more information, please contact the local authority or the dealer where you purchased the product.

Recycling

The cache backup battery unit includes a nickel-hydrate battery. A nickel-hydrate battery should be recycled when it is no longer usable. When you replace the battery unit, do not dispose of the old one in the trash. Please recycle the battery instead.

The mark posted on the battery unit is a three-arrow mark that means a recyclable part.





Glossary

This glossary provides definitions of general storage networking terms as well as specific terms related to the technology that supports your array. Click the letter of the glossary section to display that page.

#	A	B	C	D	E	F	G	H	I	J	K	L	M	N	O	P	Q	R	S	T	U	V	W	X	Y	Z
---	-------------------	-------------------	-------------------	-------------------	-------------------	-------------------	-------------------	-------------------	-------------------	-------------------	-------------------	-------------------	-------------------	-------------------	-------------------	-------------------	-------------------	-------------------	-------------------	-------------------	-------------------	-------------------	-------------------	-------------------	-------------------	-------------------

#

1000Base-T

A specification for Gigabit Ethernet over copper wire. The standard defines 1 Gbps data transfer over distances of up to 100 meters using four pairs of Category 5 balanced copper cabling and a 5-level coding scheme.

A

Array

A set of hard disks grouped logically together to function as one contiguous storage space.

ATA

Advanced Technology Attachment. A disk drive implementation that integrates the controller on the disk drive.

B

BIOS

Basic Input Output System. Built-in software code that determines the functions that a computing device can perform without accessing programs from a disk.

Bps

Bits per second. The standard measure of data transmission speeds.

C

Cache

A temporary, high-speed storage mechanism. It is a reserved section of main memory or an independent high-speed storage device. Two types of caching are found in computers: memory caching and disk caching. Memory caches are built into the architecture of microprocessors and often computers have external cache memory. Disk caching works like memory caching; however, it uses slower, conventional main memory that on some devices is called a memory buffer.

Capacity

The amount of information (usually expressed in gigabytes) that can be stored on a disk drive. It is the measure of the potential contents of a device; the volume it can contain or hold. In communications, capacity refers to the maximum possible data transfer rate of a communications channel under ideal conditions.

#	A	B	C	D	E	F	G	H	I	J	K	L	M	N	O	P	Q	R	S	T	U	V	W	X	Y	Z
---	---	---	---	---	---	---	---	---	---	---	---	---	---	---	---	---	---	---	---	---	---	---	---	---	---	---

Challenge Handshake Authentication Protocol

A security protocol that requires users to enter a secret for access.

CHAP

See Challenge Handshake Authentication Protocol.

CUDG:

Control Unit Diagnosis

D

DHCPv4

Dynamic Host Configuration Protocol version 4, allows a computer to join an IP-based network without having a pre-configured IPv4 address. DHCPv4 is a protocol that assigns unique IP addresses to devices, then releases and renews these addresses as devices leave and re-join the network.

Duplex

The transmission of data in either one or two directions. Duplex modes are full-duplex and half-duplex. Full-duplex is the simultaneous transmission of data in two direction. For example, a telephone is a full-duplex device, because both parties can talk at once. In contrast, a walkie-talkie is a half-duplex device because only one party can transmit at a time.

F

Fabric

The hardware that connects workstations and servers to storage devices in a SAN. The SAN fabric enables any-server-to-any-storage device connectivity through the use of Fibre Channel switching technology.

Firmware

Software embedded into a storage device. It may also be referred to as Microcode.

Flash memory

ROM that can be electrically erased and reprogrammed. A type of EEPROM (Electrically Erasable and Programmable). It can retain information without electricity and is widely used as an external storage, etc.

#	A	B	C	D	E	F	G	H	I	J	K	L	M	N	O	P	Q	R	S	T	U	V	W	X	Y	Z
---	---	---	---	---	---	---	---	---	---	---	---	---	---	---	---	---	---	---	---	---	---	---	---	---	---	---

FULL-duplex

The concurrent transmission and the reception of data on a single link.

G

Gbps

Gigabits per second

H

HBA

Host bus adapter. A circuit board and/or integrated circuit adapter installed in a workstation or server that provides input/output processing and physical connectivity between a server and a storage device. An iSCSI HBA implements the iSCSI and TCP/IP protocols in a combination of a software storage driver and hardware.

HDD

Hard disk drive

I

Initiator

A system component that originates an I/O command over an I/O bus or network, such as an I/O adapters or network interface cards.

I/O

Input/output.

IP

Internet Protocol. Specifies the format of packets and addressing scheme. Most networks combine IP with a higher-level protocol called Transmission Control Protocol (TCP), which establishes a virtual connection between a destination and a source.

IP address

An identifier for a computer or device on a TCP/IP network. Networks using the TCP/IP protocol route messages based on the IP address of the destination. The format of an IP address is a 32-bit numeric address written as four numbers separated by periods. Each number can be zero to 255 (for example, 192.168.0.200). The current main address is IPv4 (Internet Protocol Address Version 4) and the next-generation address is IPv6 (Internet Protocol address Version 6).

#	A	B	C	D	E	F	G	H	I	J	K	L	M	N	O	P	Q	R	S	T	U	V	W	X	Y	Z
---	---	---	---	---	---	---	---	---	---	---	---	---	---	---	---	---	---	---	---	---	---	---	---	---	---	---

IP-SAN

Block-level Storage Area Networks over TCP/IP using the iSCSI protocol.

iSCSI

Internet SCSI. An IP-based standard for connecting data storage devices over a network and transferring data using SCSI commands over IP networks. iSCSI enables a Storage Area Network to be deployed in a Local Area Network.

iSNS

Internet Storage Name Service. A protocol that allows automated discovery, management and configuration of iSCSI devices on a TCP/IP network.

L

LAN

Local Area Network. A computer network that spans a relatively small area, such as a single building or group of buildings.

Loopback address

Loopback address is a virtual address that means itself in network. In case of IPv4 uses "127.0.0.1", in case of IPv6 uses ":::1". Also "local host" is used as the host name conventionally.

LU

Logical Unit

LUN

Logical Unit Number

LRU

Least Recently Used (LRU) — An algorithm where new items are placed at the top of the cache and items at the bottom of the cache are discarded when the cache grows past its size limit. Whenever an item is accessed, it is pulled back to the top of the cache.

M

Middleware

Software that connects two otherwise separate applications. For example, a middleware product can be used to link a database system to a Web server. Using forms, users request data from the database; then, based on the user's requests and profile, the Web server returns dynamic Web pages to the user.

#	A	B	C	D	E	F	G	H	I	J	K	L	M	N	O	P	Q	R	S	T	U	V	W	X	Y	Z
---	---	---	---	---	---	---	---	---	---	---	---	---	---	---	---	---	---	---	---	---	---	---	---	---	---	---

N

NIC

Network Interface Card. An expansion board in a computer that allows the computer to connect to a network.

R

RAID

Redundant Array of Independent Disks. A disk array in which part of the physical storage capacity is used to store redundant information about user data stored on the remainder of the storage capacity. The redundant information enables regeneration of user data in the event that one of the array's member disks or the access path to it fails. SNIA.

RAID 6

An extension of the RAID 5 array, that allows for two simultaneous drive failures without downtime or data loss. recovery point objective (RPO).

After a recovery operation, the recovery point objective (RPO) is the maximum desired time period, prior to a disaster, in which changes to data may be lost. This measure determines up to what point in time data should be recovered. Data changes preceding the disaster are preserved by recovery.

S

SAN

Storage Area Network. A network of shared storage devices that contain disks for storing data.

SAS

Serial Attached SCSI. An evolution of parallel SCSI into a point-to-point serial peripheral interface in which controllers are linked directly to disk drives. SAS delivers improved performance over traditional SCSI because SAS enables up to 128 devices of different sizes and types to be connected simultaneously.

SATA

Serial ATA is a computer bus technology primarily designed for the transfer of data to and from hard disks and optical drives. SATA is the evolution of the legacy Advanced Technology Attachment (ATA) interface from a parallel bus to serial connection architecture.

#	A	B	C	D	E	F	G	H	I	J	K	L	M	N	O	P	Q	R	S	T	U	V	W	X	Y	Z
---	---	---	---	---	---	---	---	---	---	---	---	---	---	---	---	---	---	---	---	---	---	---	---	---	---	---

SCSI

Small Computer System Interface. A parallel interface standard that provides faster data transmission rates than standard serial and parallel ports.

SED

Self Encrypting Drive

Session

A series of communications or exchanges of data between two end points that occurs during the span of a single connection. The session begins when the connection is established at both ends, and terminates when the connection is ended. For some applications each session is related to a particular port. In this document a session is the exchange of data between groups of primary and secondary volumes.

SMTP

Simple Mail Transfer Protocol. A protocol used to receive and store email data directly from email servers.

Software initiator

A software application initiator communicates with a target device. A software initiator does not require specialized hardware because all processing is done in software, using standard network adapters.

Spare disk

A disk drive which is mounted separately from the disk drives for usual write and read operation. When a failure occurs in a disk drive, data stored in the failed drive is copied to the spare disk drive so that the disk array subsystem can continue to be available to the original subsystem.

SSD

Solid State Disk (drive). A data storage device that uses solid-state memory to store persistent data. An SSD emulates a hard disk drive interface, thus easily replacing it in most applications.

Storage Navigator Modular 2

A multi-featured scalable storage management application that is used to configure and manage the storage functions of Hitachi arrays. Also referred to as "Navigator 2".

Subnet

In computer networks, a subnet or subnetwork is a range of logical addresses within the address space that is assigned to an organization. Subnetting is a hierarchical partitioning of the network address space of

#	A	B	C	D	E	F	G	H	I	J	K	L	M	N	O	P	Q	R	S	T	U	V	W	X	Y	Z
---	---	---	---	---	---	---	---	---	---	---	---	---	---	---	---	---	---	---	---	---	---	---	---	---	---	---

an organization (and of the network nodes of an autonomous system) into several subnets. Routers constitute borders between subnets. Communication to and from a subnet is mediated by one specific port of one specific router, at least momentarily. SNIA.

Switch

A network infrastructure component to which multiple nodes attach. Unlike hubs, switches typically have internal bandwidth that is a multiple of link bandwidth, and the ability to rapidly switch node connections from one to another. A typical switch can accommodate several simultaneous full link bandwidth transmissions between different pairs of nodes. SNIA.

T

Target

Devices that receive iSCSI requests that originate from an iSCSI initiator.

TOE

A dedicated chip or adapter that handles much of the TCP/IP processing directly in hardware. TCP/IP transmission is inherently a CPU-intensive operation. Therefore, using dedicated hardware that can operate in parallel with the main processor allows for superior system performance. Although all iSCSI HBAs have a TOE, a generic TOE only implements TCP/IP, while an iSCSI HBA implements the iSCSI protocol in addition to TCP/IP.

U

UPS

A backup power supply, which is mounted on the Hitachi Adaptable Modular Storage Series unit to prevent shutdown of the unit even when power stoppage or momentary power interruption occurs.

#	A	B	C	D	E	F	G	H	I	J	K	L	M	N	O	P	Q	R	S	T	U	V	W	X	Y	Z
---	---	---	---	---	---	---	---	---	---	---	---	---	---	---	---	---	---	---	---	---	---	---	---	---	---	---

Index

Numerics

10/100 Ethernet management ports [4-23](#)

A

Account Authentication [7-21](#)

Alert, email [7-23](#)

Array

initial setup [7-22](#)

mounting in a rack [5-30](#)

mounting in a rack, safety [5-33](#)

array benefits [1-11](#)

array dimensions [1-2](#)

Array features [1-11](#)

Array password [7-21](#)

B

Back panel

10/100 Ethernet management ports [4-23](#)

Backup batteries [4-5](#)

charging [1-29](#)

LEDs [4-6](#)

life [1-29](#)

Base unit power requirements [5-49](#)

C

Cable diagram

expansion unit [5-38](#), [5-39](#)

high-density expansion unit [5-44](#), [5-45](#), [5-46](#)

Cable holder

ENC cable [5-41](#)

installing [5-42](#)

Cables

host interface, connecting [5-51](#)

LAN, connecting [5-48](#)

power, connecting [5-49](#)

power, routing in rack [5-50](#)

routing bars, ENC cable [5-41](#)

Cache backup times in hours [1-20](#), [A-4](#)

Clearances, installation [5-19](#)

Components

base unit front panel [4-2](#)

base unit, rear [4-8](#)

Configuration

performance tuning [7-42](#)

Configuration roadmap [7-9](#)

Configuring management ports [7-24](#)

Connecting LAN cables [5-48](#)

Connecting power cables [5-49](#)

Control Unit

FC [4-15](#)

fibre channel [4-11](#), [4-13](#), [4-15](#), [4-16](#)

iSCSI [4-19](#)

Control unit

description [4-11](#), [4-15](#)

LEDs [4-11](#), [4-15](#)

D

Data Management [1-24](#)

Day and time setting [7-52](#)

Dimensions, array [1-2](#)

Disk drive

adding [5-53](#)

LEDs [4-3](#)

slots [4-3](#)

Disk drive slots [4-3](#), [4-26](#), [4-43](#)

E

Email alert [7-23](#)

ENC Cable

Cable routing bars [5-41](#)

ENC cable

connecting to high-density expansion unit [5-42](#)

ENC Cable Holder [5-41](#)

ENC cable holder [5-41](#)

ENC cable, connecting to high-density expansion unit [5-41](#)

ENC unit

LEDs [4-32](#), [4-45](#)

Ethernet specifications [A-3](#)

Expansion unit
front panel [4-25, 4-36](#)
power requirements [5-49](#)

F

Failure monitoring [1-27](#)
Feature, connectivity [1-11](#)
Feature, high data availability [1-11](#)
features [1-13](#)
Features, fibre channel [1-12](#)
Fibre Channel
control unit [4-11, 4-13, 4-15, 4-16](#)
Fibre channel features [1-12](#)
Fibre channel port numbers [4-11, 4-15](#)
Floor loading [5-19](#)
Front and rear views, AMS 2100/2300 [1-4, 1-6](#)
Front and rear views, AMS 2300 [1-7](#)
Front bezel
removing [5-28, 5-30](#)
Front panel
disk drive slots [4-3](#)
expansion unit disk drive slots [4-26, 4-43](#)
LEDs [4-4, 4-5, 4-28](#)

H

Hitachi Simple Modular Storage
installation roadmap [5-2](#)
Host connectors
fibre channel [4-22](#)

I

Initial setup [7-22](#)
Installation
roadmap [5-2](#)
Installation roadmap, array [3-2](#)
IP Addresses
control units [5-48](#)
iSCSI [1-13](#)
Control Unit [4-19](#)
control unit [4-19](#)
interface [1-13, 2-11](#)
settings [2-11](#)

L

LEDs
base unit front panel [1-4](#)
base unit front panel, descriptions [4-4](#)
control unit [4-11, 4-15](#)
disk drive [4-3](#)
disk drive status [4-27, 4-43](#)
ENC unit, description [4-32, 4-45](#)
expansion unit front panel [4-25, 4-36](#)
expansion unit front panel, description [4-37](#)
expansion unit power supplies [4-30, 4-39](#)
front panel [4-4, 4-5, 4-28](#)
LOC [4-21](#)
LUN, mapping [1-23](#)

M

Main Switch [4-7](#)
Management ports, configuring [7-24](#)
modular 2U SAS expansion unit [4-33](#)
disk drive LEDs [4-34](#)
ENC unit [4-35](#)
front panel LEDs [4-33](#)
power unit [4-34](#)

N

Navigator 2
features [7-10](#)
installing [7-12](#)
password [7-16](#)
starting [7-16](#)
storage features [7-11](#)

O

Open systems [1-23](#)

P

Packaging, base unit [5-26](#)
Password
account authentication [7-21](#)
array [7-21](#)
Navigator 2 [7-16](#)
Performance [1-20](#)
Performance Tuning [7-42](#)
Power cables, routing in rack [5-50](#)
Power failure
cache backup times in hours [1-20, A-4](#)
restarting the system [6-6](#)
Power outage [6-6](#)
Power requirement, array [5-49](#)
Power supplies
base unit [4-9](#)
base unit safety lock [4-10](#)
expansion unit [4-30, 4-39](#)
Power switch, base unit [1-4, 4-7, 6-3, 6-4](#)

R

Rack
mounting an array [5-30](#)
mounting an array, safety [5-33](#)
RAID groups [1-22](#)
Rear panel
base unit, description [4-8](#)
expansion unit, description [4-29, 4-38](#)
Receptacles, power [4-9](#)
Reliability [1-21](#)
Replication [1-26](#)
Reset button, control unit [4-11, 4-15](#)
Roadmap
configuration [7-9](#)
Roadmap for installation [5-2](#)

Index-2

S

Safety

mounting an array in a rack [5-33](#)

Safety guidelines

electrical [5-3](#)

equipment [5-4](#)

warning labels [5-4](#)

warning labels, base unit [5-5](#)

warning labels, expansion unit [5-6](#), [5-8](#), [5-9](#), [5-10](#), [5-11](#), [5-12](#), [5-13](#), [5-14](#), [5-15](#), [5-16](#), [5-17](#)

Safety lock, power supply,

base unit [4-10](#)

expansion unit [4-31](#), [4-40](#)

Safety symbols [1-xiv](#)

Setting the day and time [7-52](#)

Site preparation [5-18](#)

Specifications

Ethernet [A-3](#)

Storage features [7-11](#)

Switch, base unit power [1-4](#), [4-7](#), [6-3](#), [6-4](#)

T

Task list, installing array [3-2](#)

Tuning, performance [7-42](#)

U

Unpacking a base unit [5-24](#), [5-26](#)

safety [5-25](#)

weight [5-25](#)

W

Warning Symbols [1-xiv](#)

Weight, base unit [5-24](#)

Hitachi Data Systems

Corporate Headquarters

2845 Lafayette Street
Santa Clara, California 95050-2639
U.S.A.

www.hds.com

Regional Contact Information

Americas

+1 408 970 1000

info@hds.com

Europe, Middle East, and Africa

+44 (0)1753 618000

info.emea@hds.com

Asia Pacific

+852 3189 7900

hds.marketing.apac@hds.com



MK-97DF8010EN-25