



Hitachi Virtual Storage Platform G1000

Hitachi Universal Volume Manager User Guide

Legal Disclaimer

No part of this publication may be reproduced or transmitted in any form or by any means, electronic or mechanical, including photocopying and recording, or stored in a database or retrieval system for any purpose without the express written permission of Hitachi, Ltd.

Hitachi, Ltd., reserves the right to make changes to this document at any time without notice and assumes no responsibility for its use. This document contains the most current information available at the time of publication. When new or revised information becomes available, this entire document will be updated and distributed to all registered users.

Some of the features described in this document might not be currently available. Refer to the most recent product announcement for information about feature and product availability, or contact Hitachi Data Systems Corporation at <https://portal.hds.com>.

Notice: Hitachi, Ltd., products and services can be ordered only under the terms and conditions of the applicable Hitachi Data Systems Corporation agreements. The use of Hitachi, Ltd., products is governed by the terms of your agreements with Hitachi Data Systems Corporation.

Notice on Export Controls: The technical data and technology inherent in this Document may be subject to U.S. export control laws, including the U.S. Export Administration Act and its associated regulations, and may be subject to export or import regulations in other countries. Reader agrees to comply strictly with all such regulations and acknowledges that Reader has the responsibility to obtain licenses to export, re-export, or import the Document and any Compliant Products.

Hitachi is a registered trademark of Hitachi, Ltd., in the United States and other countries. Hitachi Data Systems is a registered trademark and service mark of Hitachi, Ltd., in the United States and other countries.

Archivas, Essential NAS Platform, HiCommand, Hi-Track, ShadowImage, Tagmaserve, Tagmasoft, Tagmasolve, Tagmastore, TrueCopy, Universal Star Network, and Universal Storage Platform are registered trademarks of Hitachi Data Systems Corporation.

AIX, AS/400, DB2, Domino, DS6000, DS8000, Enterprise Storage Server, ESCON, FICON, FlashCopy, IBM, Lotus, MVS, OS/390, RS/6000, S/390, System z9, System z10, Tivoli, VM/ESA, z/OS, z9, z10, zSeries, z/VM, and z/VSE are registered trademarks or trademarks of International Business Machines Corporation.

All other trademarks, service marks, and company names in this document or website are properties of their respective owners.

Microsoft product screen shots are reprinted with permission from the Microsoft Corporation.



Contents

Preface.....	ix
Intended audience.....	x
Product version	x
Release notes.....	x
Document revision level.....	x
Changes in this revision.....	x
Referenced documents.....	xi
Document conventions.....	xi
Convention for storage capacity values.....	xii
Accessing product documentation.....	xiii
Getting help.....	xiii
Comments.....	xiv
1 Overview.....	1-1
Features.....	1-2
System Components.....	1-2
External storage system.....	1-3
External volume.....	1-3
Interfaces	1-3
Command Control Interface software (CCI).....	1-3
Device Manager - Storage Navigator	1-4
Spreadsheets.....	1-4
Internal volume.....	1-4
License.....	1-4
How Universal Volume Manager works.....	1-4
2 Requirements and planning.....	2-1
Planning workflow.....	2-2
System requirements.....	2-2
Planning considerations for external storage systems.....	2-4
Application performance considerations.....	2-4
Planning external volumes	2-5
Cache use and external storage performance.....	2-6
Cache Mode effects with other Hitachi software.....	2-6
Mainframe volumes.....	2-7

Open systems volumes.....	2-8
External volume groups (ExGs)	2-8
Capacity requirements for volumes	2-8
LDEV capacities per emulation type.....	2-10
Example: Determining capacity for OPEN-3 volume.....	2-11
Determining capacity for mainframe volume other than 3390-A and 3390-V.....	2-11
Adjusting volume capacities for pairs.....	2-12
Planning external paths and path groups	2-14
External paths.....	2-14
Single path mode.....	2-14
Multi path mode	2-15
Supported external systems path mode for external volumes.....	2-16
External path configurations — direct and switch	2-20
Mapping policy.....	2-21
3 VSP G1000 software supported for external volumes.....	3-1
Cache Residency Manager	3-2
Thin Image.....	3-2
Dynamic Provisioning, Dynamic Tiering, and Thin Image.....	3-3
Global-active device.....	3-3
Local replication software.....	3-3
LUN Manager and Configuration File Loader.....	3-4
Performance Monitor.....	3-4
Remote replication software	3-4
SNMP Agent	3-5
Virtual LVI/LUN (VLL)	3-5
4 Setting up external volumes.....	4-1
Setup workflow	4-2
Setting port attributes on the local system.....	4-2
Setting up ports on the external system.....	4-4
Limitations on mapping an external volume.....	4-5
Mapping an external volume.....	4-5
Preparing mapped volumes for use	4-11
Using mapped volumes	4-13
Recognizing the local system from the external system.....	4-13
5 Monitoring and maintenance.....	5-1
Monitoring external volumes and paths	5-2
Editing external volume policies (settings).....	5-2
Editing mapping policies for external volumes	5-4
Changing MP blade for external volume.....	5-5
Changing path mode to ALUA mode (Enable or Disable).....	5-7
Changing I/O mode for external storage systems.....	5-8
Editing external WWN settings	5-9
Path maintenance.....	5-11
Adding an external path to an existing path group	5-11
Changing external path priority	5-12
Disconnecting an external path	5-13

Reconnecting an external path	5-14
Changing the cache mode setting of the external volume.....	5-15
Prerequisites.....	5-15
Changing the cache mode.....	5-16
Removing, replacing an external path	5-17
Replacing all external paths	5-18
Disconnecting external systems and volumes	5-20
Prerequisites.....	5-20
Disconnecting an external storage system, all mapped volumes	5-21
Disconnecting a single mapped volume	5-22
Reconnecting external systems and volumes	5-25
Reconnecting an external storage system and all mapped volumes.....	5-25
Reconnecting a single mapped volume	5-26
Deleting an external volume mapping	5-29
Powering off and on local, external storage systems	5-31
Requirements for external storage system maintenance.....	5-31
Powering off the external storage system.....	5-32
Powering on the external storage system.....	5-33
Powering off the local storage system.....	5-33
Powering off both storage systems.....	5-34
Powering on both storage systems.....	5-34
6 Troubleshooting.....	6-1
Contacting the Hitachi Data Systems customer support.....	6-2
General troubleshooting	6-2
Troubleshooting external path status.....	6-4
Troubleshooting path errors for specific storage systems.....	6-6
VSP G1000 Storage System.....	6-7
Unified Storage VM, Virtual Storage Platform, and Universal Storage Platform V/VM.....	6-7
Universal Storage Platform / TagmaStore NSC.....	6-8
Lightning 9900 V.....	6-8
Lightning 9900.....	6-9
Thunder 9500V.....	6-10
HUS/AMS/WMS.....	6-10
SVS200	6-11
Troubleshooting port and volume discovery problems.....	6-12
A Supported external storage systems.....	A-1
External systems.....	A-3
Hitachi Virtual Storage Platform G200, G400, G600.....	A-3
HUS VM Storage System.....	A-3
Virtual Storage Platform.....	A-3
Virtual Storage Platform G1000.....	A-3
Universal Storage Platform V/VM.....	A-4
Universal Storage Platform/TagmaStore NSC	A-4
Host mode option for a volume larger than 2 TB.....	A-4
Lightning 9900 V	A-4
Lightning 9900.....	A-4
Thunder 9500V.....	A-5
Identifying the 9500 V model using the serial number.....	A-6

Identifying the controller using the port WWN.....	A-6
HUS/AMS/WMS	A-7
Identifying the HUS/AMS/WMS model using the serial number.....	A-8
Identifying the controller using the port WWN (HUS/AMS/WMS).....	A-8
Identifying logical volumes using Characteristic 1.....	A-9
Caution on using the power savings option	A-10
HUS and AMS 2000 series guidelines.....	A-10
SVS200 storage system.....	A-10
EVA storage system.....	A-11
Identifying logical volumes using Characteristic 2.....	A-11
Sun StorEdge 6120/6320.....	A-12
Sun StorageTek FlexLine 380.....	A-12
Sun StorageTek 2540.....	A-13
Sun StorageTek V2X2.....	A-13
EMC CLARiiON CX series.....	A-13
System option mode for connecting EMC CLARiiON CX series.....	A-13
System parameters for connecting EMC CLARiiON CX series.....	A-14
EMC VNX series.....	A-14
System option mode for connecting EMC VNX series.....	A-14
System parameters for connecting EMC VNX series.....	A-14
EMC Symmetrix series.....	A-15
IBM DS3000/DS4000/DS5000 series.....	A-15
IBM V7000 series.....	A-15
IBM SVC series.....	A-16
IBM XIV series.....	A-16
Fujitsu FibreCAT CX series.....	A-16
Fujitsu DX60/80/90 S2 and Fujitsu DX400 S2.....	A-17
SGI IS4600 series.....	A-17
3Par T800, F400, V800, V400 series.....	A-17
Storage system with a product name displayed as (generic).....	A-18
Support conditions when product name displays as (generic).....	A-18
Virtualization support requirements.....	A-19
Suggested virtualization procedure.....	A-20
B Remote command devices.....	B-1
Overview of remote command devices	B-2
Storage systems supported for remote command devices.....	B-2
Requirements	B-3
Restrictions and other information.....	B-4
Mapping a command device	B-5
C Command Control Interface command reference.....	C-1
Device Manager - Storage Navigator Action names and CCI commands.....	C-2
D Universal Volume Manager GUI reference.....	D-1
External Storage window	D-3
Selected external storage system window.....	D-7
Selected external path group window.....	D-10
Add External Volumes wizard	D-17
Select External Path Group window.....	D-17

Add External Volumes window.....	D-19
Add External Volumes confirmation window.....	D-25
Edit Policies window.....	D-28
Edit External Volumes wizard.....	D-29
Edit External Volumes window.....	D-30
Edit External Volumes confirmation window.....	D-31
Edit External Path Configuration wizard.....	D-32
Edit External Path Configuration window.....	D-33
Edit External Path Configuration confirmation window.....	D-35
Edit External WWNs wizard.....	D-35
Edit External WWNs window.....	D-36
Edit External WWNs confirmation window.....	D-37
Delete External Volumes wizard.....	D-37
Delete External Volumes window.....	D-38
Delete External Volumes confirmation window.....	D-39
Disconnect External Paths wizard.....	D-39
Disconnect External Paths window.....	D-40
Disconnect External Paths confirmation window.....	D-40
Reconnect External Paths wizard.....	D-41
Reconnect External Paths window.....	D-41
Reconnect External Paths confirmation window.....	D-42
Discover External Target Ports window.....	D-42
Create External Path Group window.....	D-43
Change Settings window.....	D-45
View External LUN Properties window.....	D-47
Reconnect External Storage Systems window.....	D-49
Reconnect External Volumes window.....	D-49
Disconnect External Storage Systems window.....	D-50
Disconnect External Volumes window.....	D-51
Assign MP Blade wizard.....	D-52
Assign MP Blade window.....	D-53
Assign MP Blade confirmation window.....	D-53
External LDEV Properties window.....	D-54
Discovery Result Detail window.....	D-55

Glossary

Index



Preface

This guide provides information and instructions for planning, setup, maintenance, and troubleshooting the use of external volumes with VSP G1000 and its software products.

For instructions on performing specific tasks in Hitachi Device Manager - Storage Navigator, see Universal Volume Manager software documentation.

Read this document carefully to understand how to use this product, and maintain a copy for reference.

- [Intended audience](#)
- [Product version](#)
- [Release notes](#)
- [Document revision level](#)
- [Changes in this revision](#)
- [Referenced documents](#)
- [Document conventions](#)
- [Convention for storage capacity values](#)
- [Accessing product documentation](#)
- [Getting help](#)
- [Comments](#)

Intended audience

This document is intended for system administrators, Hitachi Data Systems representatives, and authorized service providers who install, configure, and operate Hitachi Virtual Storage Platform G1000 storage systems.

Readers of this document should be familiar with the following:

- The Hitachi Virtual Storage Platform G1000 storage system and the *Hitachi Virtual Storage Platform G1000 Product Overview*.
- Data processing and RAID storage systems and their basic functions.
- The Hitachi Command Suite software and Hitachi Device Manager - Storage Navigator and the *Hitachi Command Suite User Guide* or the *Hitachi Virtual Storage Platform G1000 System Administrator Guide*.
- Storage systems that are connected to the Hitachi Virtual Storage Platform G1000 as external storage.

Product version

This document revision applies to VSP G1000 microcode 80-02-4x or later.

Release notes

The Hitachi Virtual Storage Platform G1000 Release Notes are available on the Hitachi Data Systems Portal: <https://portal.hds.com>. Read the release notes before installing and using this product. They may contain requirements or restrictions that are not fully described in this document or updates or corrections to this document.

Document revision level

Revision	Date	Description
MK-92RD8024-00	April 2014	Initial release
MK-92RD8024-01	August 2014	Supersedes and replaces MK-92RD8024-00
MK-92RD8024-02	October 2014	Supersedes and replaces MK-92RD8024-01
MK-92RD8024-03	February 2015	Supersedes and replaces MK-92RD8024-02
MK-92RD8024-04	May 2015	Supersedes and replaces MK-92RD8024-03

Changes in this revision

- Added support for Hitachi Virtual Storage Platform G200, G400, G600 as external storage systems. See [Appendix A, Supported external storage systems on page A-1](#)

- Added Attribute description to two Virtual Storage Machine table entries. See [Change Settings window on page D-45](#) and [External LDEV Properties window on page D-54](#).
- Updated cache mode information. See [Dynamic Provisioning, Dynamic Tiering, and Thin Image on page 3-3](#) and [Changing the cache mode on page 5-16](#).
- Changed "system" to "mode" and added QDepth information. See [Changing I/O mode for external storage systems on page 5-8](#), [External Paths tab on page D-5](#), [External Paths tab on page D-15](#), [Edit External WWNs window on page D-36](#), and [Edit External WWNs confirmation window on page D-37](#).
- Updated SIM timeout value. See [Mainframe volumes on page 2-7](#).

Referenced documents

Hitachi Virtual Storage Platform G1000 documents:

- *Hitachi Virtual Storage Platform G1000 Hardware Guide*, MK-92RD8007
- *Hitachi Virtual Storage Platform G1000 Product Overview*, MK-92RD8051
- *Hitachi Command Suite User Guide*, MK-90HC172
- *Hitachi Command Suite Messages*, MK-90HC178
- *Hitachi Virtual Storage Platform G1000 Performance Guide*, MK-92RD8012
- *Hitachi Virtual Storage Platform G1000 Provisioning Guide for Mainframe Systems*, MK-92RD8013
- *Hitachi Virtual Storage Platform G1000 Provisioning Guide for Open Systems*, MK-92RD8014
- *Hitachi Virtual Storage Platform G1000 System Administrator Guide*, MK-92RD8016
- *Hitachi TrueCopy® for Mainframe User Guide*, MK-92RD8018
- *Hitachi TrueCopy® User Guide*, MK-92RD8019
- *Hitachi ShadowImage® for Mainframe User Guide*, MK-92RD8020
- *Hitachi ShadowImage® User Guide*, MK-92RD8021
- *Hitachi Universal Replicator for Mainframe User Guide*, MK-92RD8022
- *Hitachi Universal Replicator User Guide*, MK-92RD8023
- *Hitachi Virtual Storage Platform G1000 Global-Active Device User Guide*, MK-92RD8072

For a list of all documents for the Hitachi Virtual Storage Platform G1000 storage system, see the *Hitachi Virtual Storage Platform G1000 Product Overview*.

Document conventions





This document uses the following terminology conventions:

Convention	Description
Hitachi Virtual Storage Platform G1000, VSP G1000	Unless otherwise noted, these terms refer to all models of the Hitachi Virtual Storage Platform G1000 storage system.

This document uses the following typographic conventions:

Convention	Description
Regular text bold	In text: keyboard key, parameter name, property name, hardware label, hardware button, hardware switch In a procedure: user interface item
<i>Italic</i>	Variable, emphasis, reference to document title, called-out term
screen text	Command name and option, drive name, file name, folder name, directory name, code, file content, system and application output, user input
< > angled brackets	Variable (used when italic is not enough to identify variable)
[] square brackets	Optional value
{ } braces	Required or expected value
vertical bar	Choice between two or more options or arguments { a b } indicates that you must choose either a or b.

This document uses the following icons to draw attention to information:

Icon	Meaning	Description
	Tip	Provides helpful information, guidelines, or suggestions for performing tasks more effectively.
	Note	Provides information that is essential to the completion of a task.
	Caution	Warns that failure to take or avoid a specified action can result in adverse conditions or consequences (for example, loss of access to data).
	WARNING	Warns the user of severe conditions, consequences, or both (for example, destructive operations).

Convention for storage capacity values

Physical storage capacity values (for example, disk drive capacity) are calculated based on the following values:

Physical capacity unit	Value
1 kilobyte (KB)	1,000 (10 ³) bytes
1 megabyte (MB)	1,000 KB or 1,000 ² bytes
1 gigabyte (GB)	1,000 MB or 1,000 ³ bytes
1 terabyte (TB)	1,000 GB or 1,000 ⁴ bytes
1 petabyte (PB)	1,000 TB or 1,000 ⁵ bytes
1 exabyte (EB)	1,000 PB or 1,000 ⁶ bytes

Logical storage capacity values (logical device capacity) are calculated based on the following values:

Logical capacity unit	Value
1 KB	1,024 (2 ¹⁰) bytes
1 MB	1,024 KB or 1,024 ² bytes
1 GB	1,024 MB or 1,024 ³ bytes
1 TB	1,024 GB or 1,024 ⁴ bytes
1 PB	1,024 TB or 1,024 ⁵ bytes
1 EB	1,024 PB or 1,024 ⁶ bytes
1 block	512 bytes
1 Cyl	For open systems: <ul style="list-style-type: none"> • OPEN-V: 960 KB • Other than OPEN-V: 720 KB For mainframe systems: 870 KB

Accessing product documentation

The Hitachi Virtual Storage Platform G1000 user documentation is available on the Hitachi Data Systems Portal: <https://portal.hds.com>. Check this site for the most current documentation, including important updates that may have been made after the release of the product.

Getting help

The Hitachi Data Systems customer support staff is available 24 hours a day, seven days a week. If you need technical support, log on to the Hitachi Data Systems Portal for contact information: <https://portal.hds.com>

Comments

Send us your comments on this document: doc.comments@hds.com. Include the document title, number, and revision level (for example, -07), and refer to specific sections and paragraphs whenever possible. All comments become the property of Hitachi Data Systems Corporation.

Thank you!

Overview

The Hitachi Universal Volume Manager software enables you to connect volumes in external storage systems to Hitachi Virtual Storage Platform G1000 (VSP G1000) software and manage them as if they were one system.

- [Features](#)
- [System Components](#)
- [How Universal Volume Manager works](#)

Features

Typically, if a system consists of multiple storage systems, the host must be connected to each of the storage systems. When configuring the connections from the host to the volumes, the system administrator must follow specific instructions for each of the storage systems.

With Universal Volume Manager, the administrator configures the connection from the host to VSP G1000 storage system and then manipulates mapped volumes in an external storage system in the same way as volumes in the VSP G1000 storage system.

With Universal Volume Manager, you can perform all procedures with the same Hitachi software as when you use VSP G1000 systems.

For example, you can use an Hitachi replication program to perform copy operations between VSP G1000 and the external systems, including the following:

- Copying data from a volume in VSP G1000 to a volume in the external system
- Copying data from a volume in an external system to a volume in another external system

System Components

Universal Volume Manager consists of the following components:

- VSP G1000 storage system, referred to as the local storage system
- Universal Volume Manager license
- External storage system
- External volumes mapped to the local storage system. The mapped external volume is referred to as an internal volume, and is a virtual representation of the external volume.
- Logical devices (LDEVs)
- External path
- Mapping path

The external storage components are illustrated in the following figure, and described in the sections that follow.

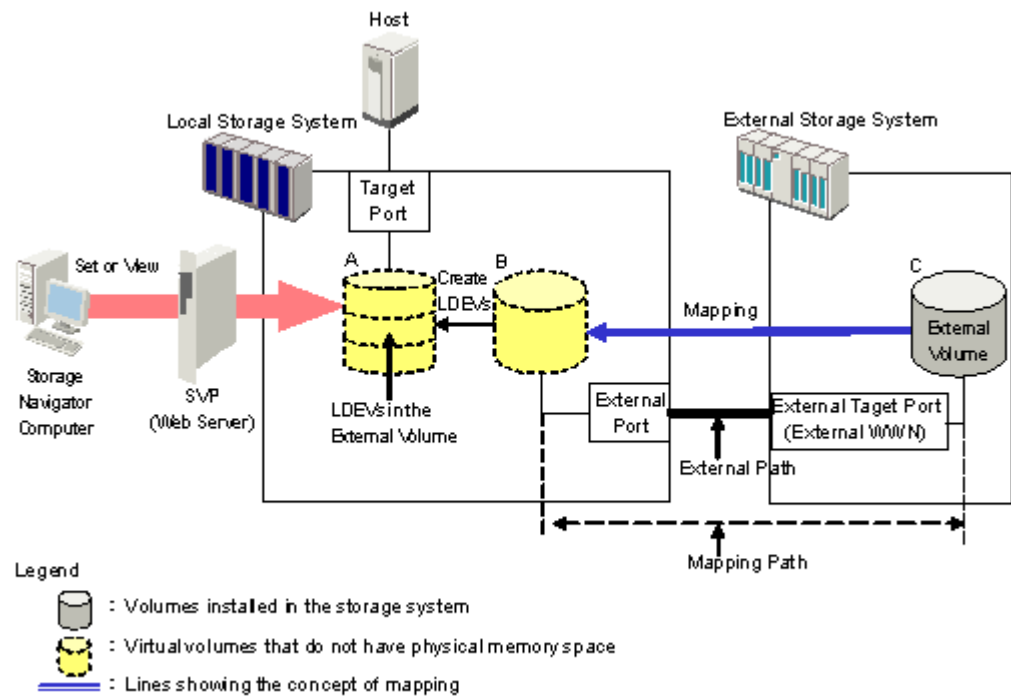

External storage system

VSP G1000 can connect to other Hitachi storage systems, original equipment manufacturer (OEM) systems, and other vendors' systems (such as IBM or EMC). Hosts recognize the volumes in these systems as internal volumes of VSP G1000.

External volume

A volume in the external storage system that is mapped to the local storage system.

Interfaces

You can perform Universal Volume Manager operations using the following interfaces:

- Command Control Interface
- Device Manager - Storage Navigator
- Spreadsheets

Command Control Interface software (CCI)

You can use the CCI CLI to perform most of the operations you perform using Device Manager - Storage Navigator. CCI operations are initiated from the host and can be automated using scripts. You can use external volumes as remote command devices.

Device Manager - Storage Navigator

Use Device Manager - Storage Navigator to manage the VSP G1000 system and the connected external storage volumes. Device Manager - Storage Navigator is run from a browser on the user-supplied computer. The operations described in this document are performed using Device Manager - Storage Navigator.

Spreadsheets

You can use spreadsheets to schedule and perform the following Universal Volume Manager operations:

- Map external volumes with one or more LDEVs to the local storage system.
- Retrieve information about mapped external volumes.
- Retrieve information about external volume groups configured on the local system.
- Retrieve information about all SSIDs in the local system.
- Disconnect and reconnect an external volume or an external storage system.
- Delete external volume mapping.
- Move an external volumes from one path group to another existing group or to a new group.

Internal volume

A volume managed by the local storage system. An internal volume can be a physical volume or the virtual representation of an external volume.

License

Universal Volume Manager is a Hitachi software product requiring installation of a license key. See the *Hitachi Virtual Storage Platform G1000 System Administrator Guide* for instructions.

How Universal Volume Manager works

When you map to a volume in an external storage system, it becomes an internal volume in VSP G1000.

- A local system port must be connected to the external storage system port with a fibre channel cable. This route between ports is the external path.
- The external volume is represented in the VSP G1000 as an internal volume, and the path between them is the “mapping path”.
- The figure below shows the connection between the local and external storage systems. In this figure, the external system is connected to the

local system's "external ports" via a switch using the Fibre Channel interface. An "external port" is an attribute assigned to VSP G1000 ports.

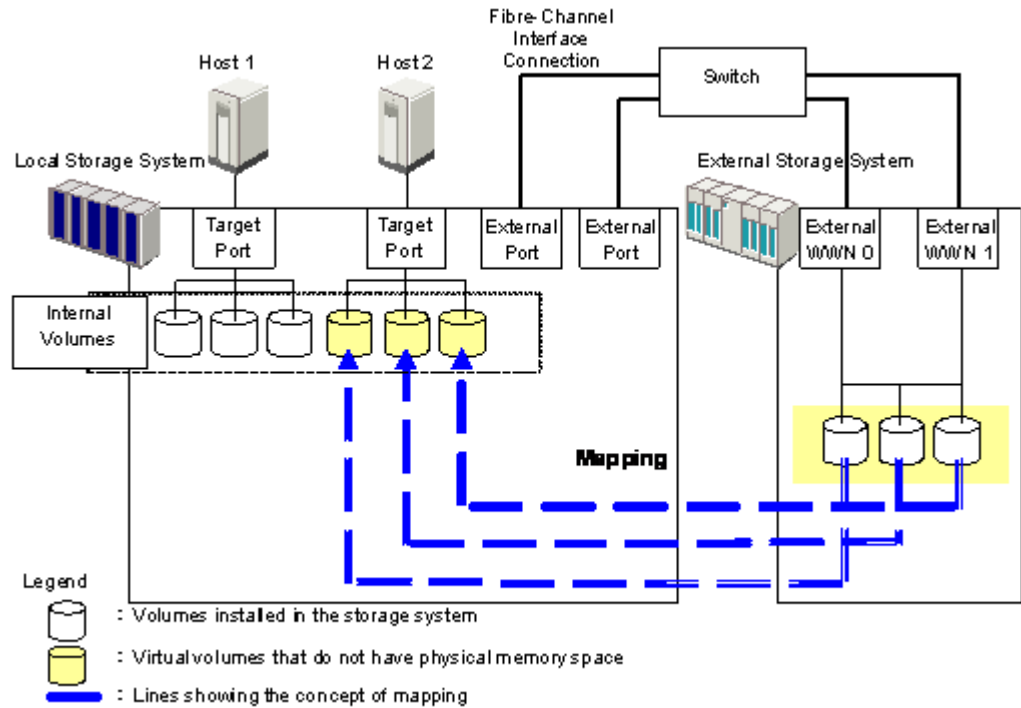

You can connect multiple external storage systems to one external port even if the external port is already in use.

Note: Only hosts that are connected to the VSP G1000 can access and copy mapped external volumes.

You can create LDEVs during or after the mapping operation. If you create the LDEVs after mapping, the creation process is the same as when you create internal volumes using Virtual LVI/Virtual LUN. As shown in the figure above, you must have LDEVs in the mapped external volumes for use in the local system.

LDEVs are created in two different ways, by using Universal Volume Manager during mapping or by using the Virtual LVI/LUN (VLL) function after mapping. In the VLL function, the external volume (the internal volume to which an external volume is mapped) is the virtual device (VDEV) and the LDEV in the external volume is the LDEV. After the mapping completes, new LDEVs are created in the same way they are when you create internal volumes using the VLL function. As shown in the figure, the LDEVs in the mapped external volumes are required in the local storage system.

Requirements and planning

This topic describes requirements and planning.

- [Planning workflow](#)
- [System requirements](#)
- [Planning considerations for external storage systems](#)
- [Application performance considerations](#)
- [Planning external volumes](#)
- [Planning external paths and path groups](#)
- [Mapping policy](#)

Planning workflow

Before mapping an external volume to VSP G1000, review the information in this chapter to ensure that you understand the Universal Volume Manager requirements and implementation procedures.

Use the general order in the following to prepare for Universal Volume Manager:

Procedure:

1. Review [System requirements on page 2-2](#).
2. Verify that the external storage system whose volumes you want to map is supported by Universal Volume Manager. See [Appendix A, Supported external storage systems on page A-1](#).
3. Verify that the functionality you want is supported for mapped external volumes. See [Chapter 3, VSP G1000 software supported for external volumes on page 3-1](#).
4. In the external storage system, select a port and set parameters, as necessary. See [Setting up ports on the external system on page 4-4](#).
5. In the local storage system, identify the port to be connected to the external storage system and make sure it is specified as an external port. See [Setting port attributes on the local system on page 4-2](#).
6. Plan data paths from the local storage system to the external storage system. See [Planning external paths and path groups on page 2-14](#).
7. In the external storage system, prepare volumes for use in the local storage system. For example, if you plan to use an external volume for replication, verify that it meets the requirements for the Hitachi replication software.

See the following for instructions and additional information.

- [Planning external volumes on page 2-5](#)
 - [Mainframe volumes on page 2-7](#)
 - [Open systems volumes on page 2-8](#)
 - [Capacity requirements for volumes on page 2-8](#)
8. In the local storage system, configure the external volume groups to which you will assign the external volume during the mapping operation. See [External volume groups \(ExGs\) on page 2-8](#).
 9. Optionally, change the default values of the mapping settings before performing the operation. See [Editing external volume policies \(settings\) on page 5-2](#).

System requirements

You can perform Universal Volume Manager (UVM) operations between the local storage system - VSP G1000 - and volumes in an external storage system. General requirements for these and all UVM components are described below.

Item	Description
Virtual Storage Platform G1000 (VSP G1000)	<ul style="list-style-type: none"> Required for the local storage system. All hardware and microcode must be installed.
External storage systems	You must have at least one external storage system. See Appendix A, Supported external storage systems on page A-1 for details about the supported external storage systems.
UVM license key	Required. See the <i>Hitachi Virtual Storage Platform G1000 System Administrator Guide</i> for installation and operations instructions.
Other VSP G1000 software licenses	As needed. See Chapter 3, VSP G1000 software supported for external volumes on page 3-1 for VSP G1000 software and functions that can be used with external volumes.
Device Manager - Storage Navigator	Required.
RAID level	<p>External volumes are RAID 1 and display in the following cases:</p> <ul style="list-style-type: none"> VSP G1000 internal processing. (A bar (-) displays on the Device Manager - Storage Navigator windows.) Information about the external storage system that is reported to a higher-level device (OS). <p>VSP G1000 uses RAID 1 cache management for external volumes. The external storage controller is responsible for physical RAID methods.</p>
Ports in external storage system	<ul style="list-style-type: none"> Maximum = 1,024 ports Can be connected with VSP G1000. WWN is the port identification number.
Maximum number of mapped external volumes	<ul style="list-style-type: none"> Maximum = 63,232 For Thin Image and Dynamic Provisioning: $\text{Number of external volumes} + \text{Number of virtual volumes} \leq 63,232$
Number of external volume groups	Maximum = 16,384
Number of volumes registered in external volume group	Maximum = 4,096
Number of mapping paths	<ul style="list-style-type: none"> One required Two or more recommended Maximum = 8 per external volume
Minimum capacity of an internal volume	The minimum capacity of an internal volume changes depending on the emulation type. See LDEV capacities per emulation type on page 2-10 .
Minimum capacity of an external volume	<p>83,520 blocks (about 41 MB).</p> <p>However, when the emulation type is OPEN-V, the minimum capacity is 96,000 blocks (about 47 MB).</p>

Item	Description
Maximum capacity of an external volume	<ul style="list-style-type: none"> • 128,849,011,200 blocks (59.99 TB) • You can create a volume with more than 59.99 TB, but you can only use 59.99 TB as a mapped external volume. • Use Virtual LVI/Virtual LUN to create multiple LDEVs of OPEN-V up to the maximum LDEV size of 3.99 TB each.
Maximum number of external volumes that can be mapped per port	<p>4,096</p> <p>If one external port is connected to several target ports through switches, the maximum number of LUs defined for the connected target ports is 4,096.</p>

Planning considerations for external storage systems

An external storage system's performance is affected by local system operations. Conversely, performance of the host and local system are affected by the attributes assigned to the external system.

Note the following regarding performance:

- You can improve the host I/O performance for sequential writes to mapped volumes by setting SOM 872 to ON. For more information, contact Hitachi Data Systems customer support.
- The performance and status of the external system affects the performance of the mapped external volume. A high number of processes running on the external system slows the processing speed of read/write requests and might cause a missing interrupt handler.
- If the host connected to the local storage system issues several I/O requests to be processed by the external storage system, the requests from the host may time out.
- When you execute VSP G1000 software commands that result in more I/O requests being processed than the external storage system can handle, the commands might time out and an error might occur.
- When there is a process running between an external volume and the host, it is important that the Path Blockade Watch time of the external volume is the same as or shorter than the timeout period of the process that is running on the host. If the value of the Path Blockade Watch time setting is longer than the timeout period of the process running on the host, the process on the host might time out if the power supply is interrupted or if an error occurs in the external storage system.

Application performance considerations

When you use external storage, you should keep the following recommendations in mind regarding application performance:

- Internal storage typically provides faster response times than external storage when the storage is of the same type.

- Storage used by the application must have the proper performance characteristics.
For example, SATA storage does not provide the performance requirements usually needed for an OLTP application.
- The mainframe Transaction Processing Facility (TPF) does not support external storage.

Planning external volumes

External volumes must meet the Universal Volume Manager requirements. When planning external volumes, note the following:

- You can use existing data in an external volume after it is mapped to the local system, with the following restrictions:
 - You must set the emulation type to OPEN-V when you map the volume.
 - To perform host I/O operations, you must set an LU path from the target port to the mapped volume.
- The maximum or minimum available capacity of an external volume depends on the emulation type you specify when mapping the volume. See [Capacity requirements for volumes on page 2-8](#) for more information.
- You cannot access data stored in an external volume that exceeds the allowed maximum capacity. See "Maximum capacity of an external volume" in [System requirements on page 2-2](#).
- Make sure that a mapped external volume is accessed only from the local VSP G1000 storage system.
 - Make sure that a mapped external volume is not accessed from a host that is connected to the external storage system.
 - Make sure that a mapped external volume is not manipulated by a copy function or any other functions of the external storage system.
 - Accessing a mapped external volume from the external storage system requires that the volume mapping be disconnected first.
- External volumes that are reserved by a host cannot be mapped as internal volumes. To map these volumes, cancel the reserve settings, remove host access to the volumes, and then perform the mapping operation.
- Do not map multi-platform volumes of external storage systems as internal volumes.
- When an external storage system that uses control unit path ownership is connected to VSP G1000, configure the external path to the primary controller in the external storage system as the primary path.
Ownership is the exclusive right to control volumes. A controller that has ownership is called a primary controller. If the external path is connected to a controller that does not have ownership, and the path is configured

as primary path, the ownership will be transferred, which may affect performance.

- A management LU cannot be used as an external volume.
A management LU receives commands from an application; it controls or manages the application, and stores control information from the application. An example of a management LU is a Universal Xport LU. (A CCI command device is not a management LU.)

Before performing the external volume mapping operation, perform one of the following operations on the external storage system.

- Delete the management LU from the port to be connected to the VSP G1000.
- Make sure that at least one LU is used for data storage and has a smaller LUN (LU number) than the management LU's LUN. Also make sure that the data storage LU is set to the port connected to VSP G1000.
- Use the security function and configure the access attribute of the management LU to prohibit read and write operations.

An external storage system that has a management LU might not be recognized by the local storage system.

Cache use and external storage performance

The Cache Mode setting, which you specify during a mapping operation, and a proper cache configuration affect the performance of the external storage used with VSP G1000.

When data is written to the mapped external volume, Cache Mode controls when the write-complete response is sent to the host.

- When Enabled is specified, the write-complete response is sent when the write data is in VSP G1000 cache.
- When Disabled is specified, the write-complete response is sent when the write data is accepted by the external system.

Disabled is the safest setting and is recommended when there is a possibility that the I/O rate will exceed the short term capabilities of the external storage.

Enabled can adversely impact overall VSP G1000 performance if the I/O rate exceeds the performance capabilities of the external system. If you specify Enabled, you must use the same formula for sizing cache in both the internal and external systems.

If you specify Enabled for Cache Mode, you must define a cache partition. A CLPR helps to protect VSP G1000 performance when the I/O rate exceeds the capabilities of the external system.

Cache Mode effects with other Hitachi software

Note the following additional effects regarding the **Cache Mode** setting:

- If you perform the Cache Residency Manager bind mode operation on an external volume, your system must have twice as much cache capacity as user data area capacity. If the bind mode is set for Cache Residency, you cannot change the mode from Enable to Disable. If you want to change to Disable, either release the Cache Residency setting or change the Cache Residency operation mode to priority mode.
- The external volumes in a Dynamic Provisioning pool must all use the same Cache Mode setting, either Enabled or Disabled.
- Data that is not written by the host (for example, data written by ShadowImage) is asynchronously destaged to the external storage system regardless of the Cache Mode setting.
- When you set emulation type for a mainframe system, note the following:
 - Data written by a host using a Format Write command is asynchronously destaged to the external storage system regardless of the Cache Mode setting.
 - Data written by a host using other Write commands are destaged to the external storage system as configured in the Cache Mode setting.

Mainframe volumes

Note the following requirements and considerations for mapping mainframe external volumes:

- Make sure that mainframe external volumes on a mainframe operating system consist of at least one LDEV before mapping.
- When multiple LDEVs exist in an external volume and numerous I/Os are made to them, read/write commands may timeout. When the commands timeout, the SIM (21d2xx) is reported.
- Set the MIH (missing interrupt handler) timer to 45 seconds (which is the recommended value) for mainframe external volumes on a mainframe operating system.
- VSP G1000 does not recognize pre-existing mainframe volumes on an external system that are accessed by FICON channels so you cannot map these volumes to the local storage system.

You can prepare mainframe external volumes for mapping using one of the following methods:

- Zero-format the external volumes on the external system, map the volumes to VSP G1000, then perform the Write to Control Blocks operation using Virtual LVI/Virtual LUN on the local system side.
- Map the external volumes to VSP G1000, and then format the mapped volumes on the local storage system using the Virtual LVI/Virtual LUN. After the mapping operation completes, the status of the mapped volume is **Blockade**; however, after the Write to Control Blocks operation completes or the mapped volume is formatted on the local system, the mainframe host can access the new mainframe volume through the FICON channels of the local VSP G1000 system.



Note: A good reason to format from the local system side is that if you format the mapped volume from the external system, existing data is deleted and there are no options for retaining it.

For information on formatting and the Write to Control Blocks operations, see the *Hitachi Virtual Storage Platform G1000 Provisioning Guide for Open Systems*.

Open systems volumes

Note the following requirements and considerations for mapping OPEN systems external volumes:

- OPEN systems external volumes do not require reformatting because the connection between VSP G1000 and the external system is Fibre Channel. However, if you need to initialize the data area for the volume, format the volume using the Virtual LUN function. See the *Hitachi Virtual Storage Platform G1000 Provisioning Guide for Open Systems* for instructions.
- OPEN-V emulation provides the most efficient use of storage and the best performance. Also, emulation types other than OPEN-V may not retain existing data after being mapped.

External volume groups (ExGs)

During the mapping operation, you assign the external volume to an external volume group. This allows you to organize external volumes used for similar purposes to a particular group or groups.

For example, you may want to assign mapped volumes in the same external system to a specific ExG. Or, you may assign volumes used in a particular function, such as ShadowImage or Universal Replicator, to an ExG, even if the data is stored in different external storage systems.

You could also use ExGs to correspond to the external system's physical disk grouping, such as a RAID group.

You assign external volume group numbers during the mapping procedure.

Capacity requirements for volumes

The capacity of an external volume is carved into LDEVs when mapped to the local system as an internal volume. This chapter describes information and instructions for calculating the capacity that the internal volume will have.

Note the following regarding internal/external volume capacity:

- The LDEV size in the internal volume varies according to the external system's emulation type.
- An external volume whose capacity is less than the minimum LDEV capacity cannot be used.
- An external volume with a capacity that is less than the base LDEV capacity for the emulation type can be used; this causes a custom-sized

volume (CV) to be automatically created in the local system during mapping.

- A custom volume in the local system has a minimum capacity, called minimum LDEV capacity.
- Base LDEV capacity must be equal to or greater than the minimum LDEV capacity.

The following figure illustrates minimum and base LDEV capacities. Minimum LDEV capacity and Base LDEV capacity are calculated with the following formulas.

$$\text{Minimum LDEV Capacity} = \text{Minimum Data Area Capacity} \setminus + \text{Control Information Area Capacity}$$
$$\text{Base LDEV Capacity} = \text{Base Data Area Capacity} \setminus + \text{Control Information Area Capacity}$$

For mainframe systems volumes, other than 3390-A and 3390-V, capacities for the expanded control information area and the adjustment area are also necessary. For details, see [Determining capacity for mainframe volume other than 3390-A and 3390-V on page 2-11](#).

If the external volume capacity is less than the minimum LDEV capacity, you cannot specify the emulation type.

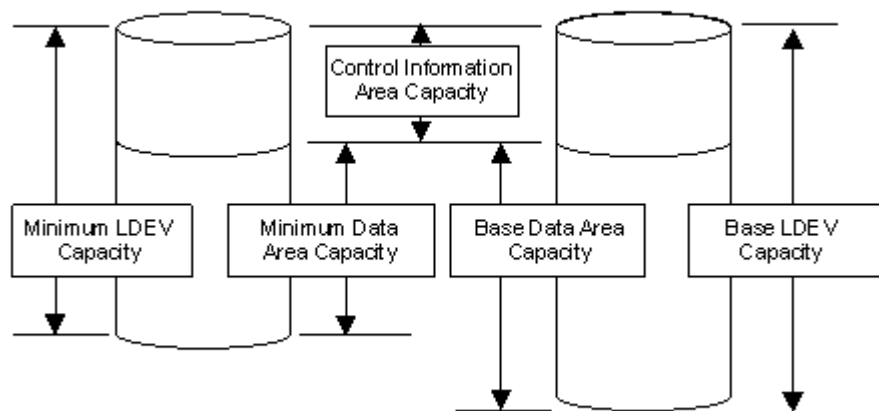

Figure 2-1 Idea of LDEV capacity

- If you map an external volume that has a capacity that is higher than the base LDEV capacity for the emulation type, multiple LDEVs are created. The resulting LDEVs have the base LDEV capacity.
- When using VLL, you can create a maximum of 2,048 CVs. (VLL is not supported for the OPEN-L emulation type.)
- For emulation types other than OPEN-V, usable capacity in the internal volume is the capacity of the external volume minus control information area capacity.

- Data that exceeds the maximum capacity cannot be accessed.

LDEV capacities per emulation type

The following table shows LDEV capacities for each emulation type in units of blocks and cylinders. The number of cylinders in this section is calculated as: 1 cylinder = 1,740 blocks.

Emulation Type		Minimum Data Area Capacity		Base Area Capacity		Control Information Area Capacity	
		Blocks	Cylinders	Blocks	Cylinders	Blocks	Cylinders
Volume for open systems	OPEN-3	72,000	-	4,806,720	-	11,520	-
	OPEN-8	72,000	-	14,351,040	-	338,880	-
	OPEN-9	72,000	-	14,423,040	-	338,880	-
	OPEN-E	72,000	-	28,452,960	-	27,360	-
	OPEN-K	72,000	-	3,661,920	-	12,960	-
	OPEN-L	71,192,160	-	71,192,160	-	10,080	-
	OPEN-V	96,000	-	8,589,934,592	-	0	-
Volume for mainframe systems	3390-1	87,000	50	1,936,620	1,113	8,700	5
	3390-2	87,000	50	3,873,240	2,226	10,440	6
	3390-3	87,000	50	5,809,860	3,339	10,440	6
	3390-9	87,000	50	17,429,580	10,017	43,500	25
	3390-L	87,000	50	57,002,400	32,760	40,020	23
	3390-M	87,000	50	114,004,800	65,520	92,220	53
	3390-A ²	1,936,620	1,113	457,042,320	262,668	12,180	7
	3390-V	87,000	50	1,944,902,400	1,117,760	0	0
Intermediate volume	3390-3A	87,000	50	5,809,860	3,339	10,440	6
	3390-3B	87,000	50	5,809,860	3,339	10,440	6
	3390-3C	87,000	50	5,809,860	3,339	10,440	6
	3390-9A	87,000	50	17,429,580	10,017	43,500	25
	3390-9B	87,000	50	17,429,580	10,017	43,500	25
	3390-9C	87,000	50	17,429,580	10,017	43,500	25
	3390-LA	87,000	50	57,002,400	32,760	40,020	23
	3390-LB	87,000	50	57,002,400	32,760	40,020	23
	3390-LC	87,000	50	57,002,400	32,760	40,020	23
	3390-MA	87,000	50	114,004,800	65,520	92,220	53
	3390-MB	87,000	50	114,004,800	65,520	92,220	53
	3390-MC	87,000	50	114,004,800	65,520	92,220	53

Emulation Type	Minimum Data Area Capacity		Base Area Capacity		Control Information Area Capacity	
	Blocks	Cylinders	Blocks	Cylinders	Blocks	Cylinders
Note: For 3390-A, the control information area is required for each 1,113 cylinders.						

Example: Determining capacity for OPEN-3 volume

The following figure illustrates capacity for an external volume with OPEN-3 emulation type. The capacity is 1,610,612,640 blocks. You can create 334 LDEVs from the base LDEV capacity of 4,818,240 blocks (Base Data Area plus Control Information Area) using the data for OPEN-3 in [LDEV capacities per emulation type on page 2-10](#). This process creates free space of 1,320,480 blocks of the mapped external volume. You can create LDEVs in free space using VLL.

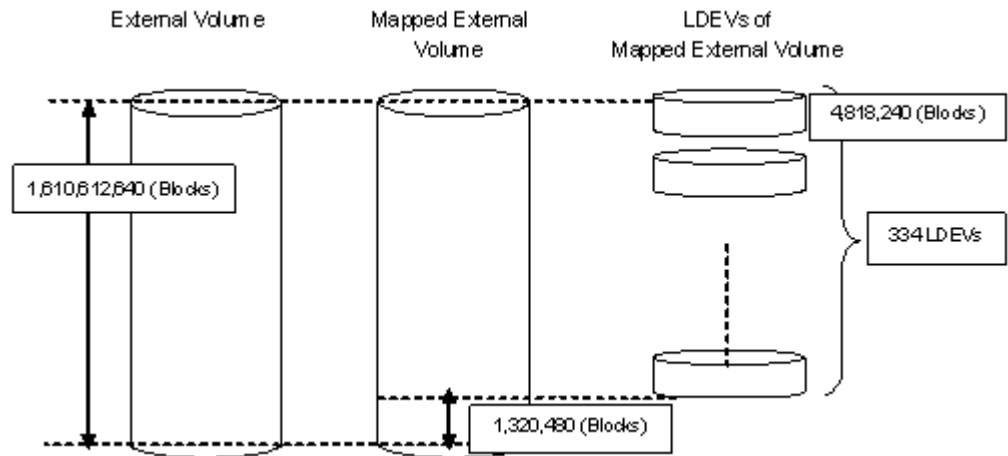

Determining capacity for mainframe volume other than 3390-A and 3390-V

For mainframe volumes other than 3390-A and 3390-V, an expanded control information area of 7 cylinders (12,180 blocks) is required for every 1,113 cylinders (1,936,620 blocks). The area total includes the minimum or base data area and the control information area. Because you must be able to divide the entire LDEV capacity by 77,952 blocks, you must include an adjustment area in the LDEV capacity.

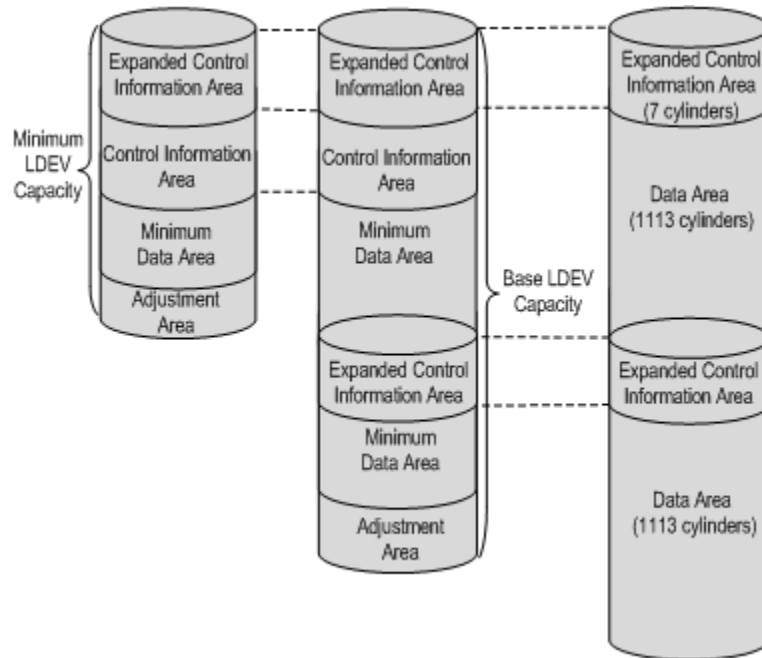

Formula for calculating necessary LDEV capacities (in blocks)

ceil: rounding up the first decimal place to the nearest integer

$$\text{Minimum LDEV capacity} = \text{ceil}(\{\text{ceil}((\text{Minimum data area capacity} \setminus + \text{Control information area capacity}) / 1,936,620) \times 12,180 \setminus + (\text{Minimum data area capacity} \setminus + \text{Control information area capacity})\} / 77,952) \times 77,952$$

$$\text{LDEV capacity} = \text{ceil}(\{\text{ceil}((\text{Base data area capacity} \setminus + \text{Control information area capacity}) / 1,936,620) \times 12,180 \setminus + (\text{Base data area capacity} \setminus + \text{Control information area capacity})\} / 77,952) \times 77,952$$

Minimum LDEV capacity and Base LDEV capacity for mainframe systems

Emulation type	Minimum LDEV capacity (blocks)	Base LDEV capacity (blocks)
3390-1	155,904	2,026,752
3390-2	155,904	3,975,552
3390-3	155,904	5,924,352
3390-9	155,904	17,617,152
3390-L	155,904	57,450,624
3390-M	233,856	114,823,296

Adjusting volume capacities for pairs

Mapped external volumes can be used for replication. All VSP G1000 replication software requires a pair's secondary volume (S-VOL) to have the same capacity as the primary volume (P-VOL).

If you need to adjust the capacity of the VSP G1000 volume or the external volume before creating the pair, proceed as shown in the following subtopics.

Decreasing the size of the VSP G1000 S-VOL

When the VSP G1000 volume S-VOL is larger than the mapped external volume P-VOL, adjust the VSP G1000 volume's capacity as follows:

Procedure:

1. Map the external volume with emulation type OPEN-V.
2. Make sure the VSP G1000 volume's emulation type is OPEN-V.
3. Decrease the size of the VSP G1000 S-VOL by creating a custom volume (CV) using Virtual LVI/Virtual LUN, as shown in the following figure.

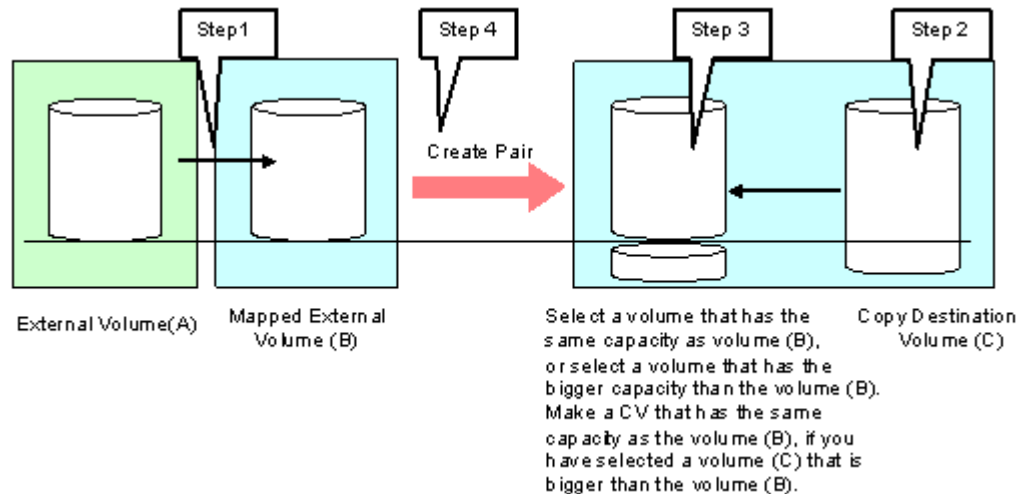

Base the CV capacity on Blocks, which displays in the **Capacity** column on the **LDEV Information** dialog box in Device Manager - Storage Navigator. See the *Hitachi Virtual Storage Platform G1000 Provisioning Guide for Open Systems* and the *Hitachi Virtual Storage Platform G1000 Provisioning Guide for Mainframe Systems* for instructions on creating CVs.

4. Create the pair.

Decreasing the size of the external volume S-VOL

When the mapped external volume S-VOL is larger than the VSP G1000 P-VOL, adjust the external volume's capacity as follows:

Procedure:

1. Map the external volume with the same emulation type as the VSP G1000 primary volume.
2. After mapping, check the new internal volume's capacity. If it is larger than the VSP G1000 P-VOL, decrease the size by creating a CV that is the same size as the VSP G1000 P-VOL using Virtual LVI/Virtual LUN (see the following figure).

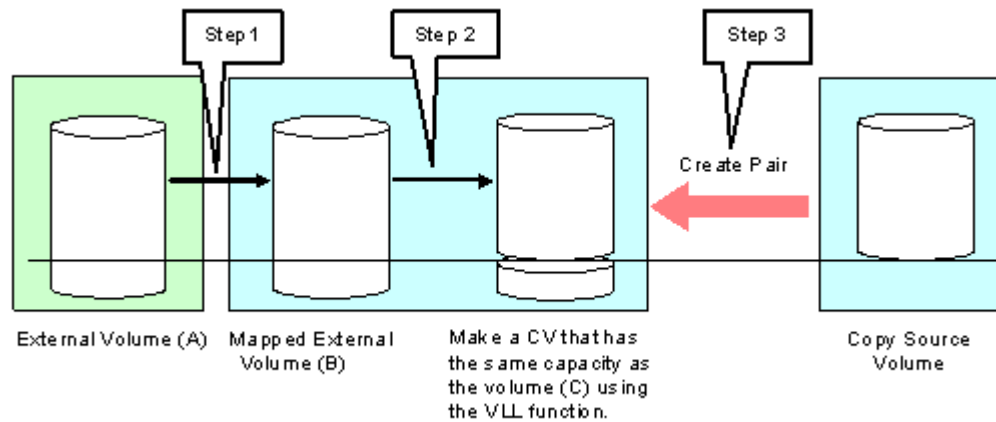

3. Create the pair.

Planning external paths and path groups

The external path is the physical link from the local storage system port to the external storage system port. You prepare the ports on the local and external systems and then set up the external path prior to mapping your external volumes.

To prepare and set up ports, see the following sections:

- [Setting port attributes on the local system on page 4-2](#)
- [Setting up ports on the external system on page 4-4](#)

External paths

A path consists of cables and possibly switches. You configure your path according to bandwidth considerations, which include distance, speed, and performance requirements.

Because workload can spike and cable or switch failures can occur, Hitachi strongly recommends that you set up redundant external paths. A maximum of eight paths can be used per mapped external volume. Multiple paths—redundancy—allows you to perform I/O operations with external volumes regardless of workload and/or path failure.

With multiple paths, the external storage system determines how they are used: some systems use one primary path with alternates available as backups (Single path mode); other systems allow all paths to be used at the same time, distributing I/O among them (Multi path mode). The path storage system's mode cannot be changed. With both modes, you place the paths in path groups and prioritize each path.

Single path mode

For Single path mode, the external path with the highest priority (primary path) is used to execute I/O to the external volume. If the primary path cannot be used, the path with the second highest priority is used.

The following figure illustrates how failure is handled with redundant paths in Single path mode.

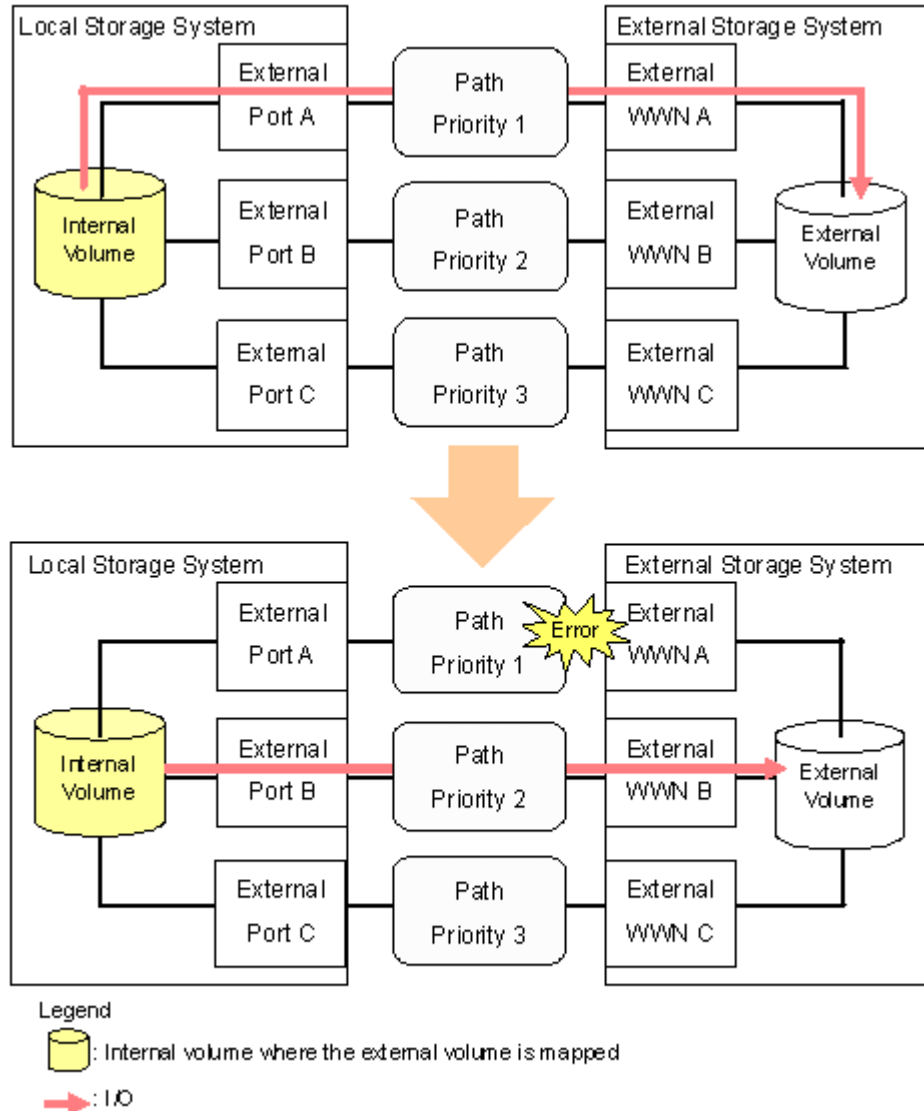

When you restore a path with higher priority than the currently-used path, I/O is switched to the restored path.

Multi path mode

For Multi path mode, all paths are used for I/O to the external volume. This distributes workload in a round-robin process.

The following figure illustrates how failure is handled with redundant paths in Multi mode.

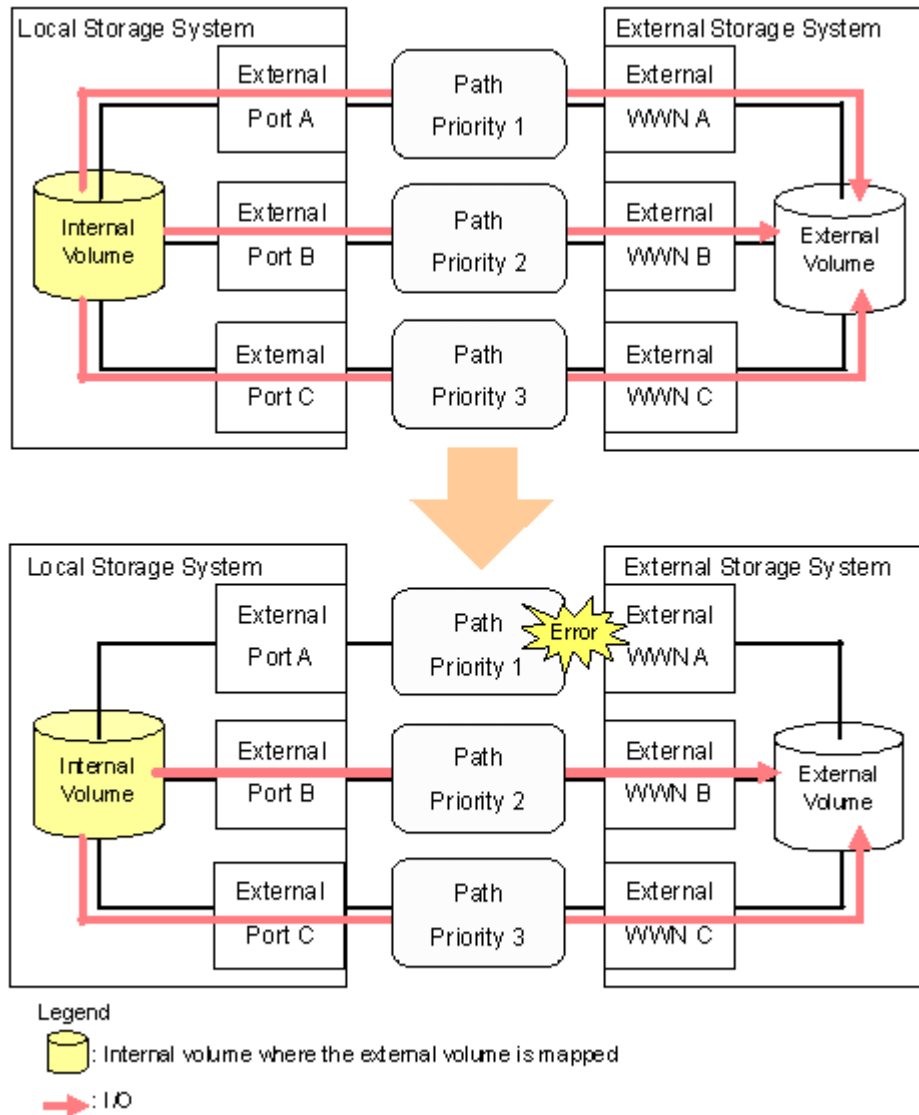

Note: When you restore a path, use of the restored path is resumed.

Supported external systems path mode for external volumes

"Single" or "Multi" path mode displays in Device Manager - Storage Navigator for external volumes on the **External Path Group** window. Path modes are based on the external storage system and cannot be changed.

In ALUA mode, the storage system uses all paths that are defined. The storage system performs I/O operations for external volumes through load balancing with the use of several paths (round-robin control). The storage system does not use external paths connected to ports that are in Passive status.

Load Balance Mode

When the path mode of an external volume is Multi or ALUA, you can select an I/O control system for the external storage system.

- **Depend on the selected external volume(s):** If **Enable** is set for **ALUA Settable** on the external volume, **Normal Round-robin** is set for Load Balance Mode automatically. If **Disable** is set for **ALUA Settable**, **Disable** is set for Load Balance Mode automatically.
- **Normal Round-robin:** Normal multi-path I/O control system. This distributes I/O to several paths on which I/O operation is enabled for the external storage system. Specify this if Extended Round-robin may lower I/O performance. This mode is recommended when the number of sequential I/O operations is small.
- **Extended Round-robin:** Extended multi-path I/O control system. I/O is distributed to several paths on which I/O operation is enabled for the external storage system. For sequential I/O, the external volume is divided into sections at regular intervals. In this case, the same path is used for I/O within the same section which reduces the frequency of I/O distribution. You can improve the read speed by using the cache function of the external storage system for sequential I/O operations. This mode is recommended when the number of sequential I/O operations is large.
- **Disable:** I/O operation is performed with only one path that is normal and has the highest priority. The same operation applies as that for Single path mode. When **Disable** is set for **Load Balance Mode**, load distribution is not performed. This mode is not recommended.



Caution: Depending on the external storage type and system configuration, performance may not be improved when **Extended Round-robin** is set. In that case, **Normal Round-robin** is recommended.

The following table shows the path mode for many of the supported external storage systems. The table also shows the abbreviation used in Device Manager - Storage Navigator.

If your system is not shown below, refer to <http://www.hds.com/products/storage-systems/specifications/supported-external-storage.html>.

Storage System	Reference
Hitachi Virtual Storage Platform G1000	<ul style="list-style-type: none">• Path Mode: Multi• Displays as "Hitachi Virtual Storage Platform G1000".
Unified Storage VM	<ul style="list-style-type: none">• Path Mode: Multi• Displays as "HUS VM".
Hitachi Virtual Storage Platform	<ul style="list-style-type: none">• Path Mode: Multi• Displays as "VSP".
Hitachi Universal Storage Platform V	<ul style="list-style-type: none">• Path Mode: Multi• Displays as "USP V".

Storage System	Reference
Hitachi Universal Storage Platform VM	<ul style="list-style-type: none"> • Path Mode: Multi • Displays as "USP VM".
Hitachi TagmaStore® Universal Storage Platform	<ul style="list-style-type: none"> • Path Mode: Multi • Displayed "USP".
Hitachi TagmaStore® Universal Storage Platform	<ul style="list-style-type: none"> • Path Mode: Multi • Displays as "NSC".
Hitachi Unified Storage	<ul style="list-style-type: none"> • Path Mode: Multi • Displays as "HUS".
Hitachi Adaptable Modular Storage	<ul style="list-style-type: none"> • Path Mode: <ul style="list-style-type: none"> - Multi: AMS2500, AMS2300, AMS2100, or AMS2010 - Single: AMS1000, AMS500, or AMS200 • Displays as "AMS".
Hitachi Workgroup Modular Storage	<ul style="list-style-type: none"> • Path Mode: Single • Displays as "WMS".
Hitachi Simple Modular Storage	<ul style="list-style-type: none"> • Path Mode: Multi • Displays as "SMS".
Hitachi Lightning 9900 V Series	<ul style="list-style-type: none"> • Path Mode: Multi • Displays as "9970V" and "9980V".
Hitachi Lightning 9900 Series	<ul style="list-style-type: none"> • Path Mode: Multi • Displays as: <ul style="list-style-type: none"> - Lightning 9960: "0400". - Lightning 9910: "0401".
Hitachi Thunder 9500V series	<ul style="list-style-type: none"> • Path Mode: Single • Displays as "9500V".
Hitachi SANRISE Universal Storage Platform	<ul style="list-style-type: none"> • Path Mode: Multi • Displays as "USP".
Hitachi SANRISE Network Storage Controller	<ul style="list-style-type: none"> • Path Mode: Multi • Displays as "NSC".
Hitachi SANRISE 9900V series	<ul style="list-style-type: none"> • Path Mode: Multi • Displays as "9970V" and "9980V".
Hitachi SANRISE 9500V series	<ul style="list-style-type: none"> • Path Mode: Single • Displays as "9500V".
Hitachi SANRISE 2000 series	<ul style="list-style-type: none"> • Path Mode: Multi • Displays as: <ul style="list-style-type: none"> - SANRISE 2800: "0400". - SANRISE 2200: "0401".

Storage System	Reference
HP Virtual Storage Platform VX7	<ul style="list-style-type: none"> • Path Mode: Multi • Displays as "XP7".
HP Virtual Storage Platform VP9500	<ul style="list-style-type: none"> • Path Mode: Multi • Displays as "P9500".
A/H-6593	<ul style="list-style-type: none"> • Path Mode: Multi • Displays as "300".
HP H24000	<ul style="list-style-type: none"> • Path Mode: Multi • Displays as "24000".
HP H20000	<ul style="list-style-type: none"> • Path Mode: Multi • Displays as "20000".
HP SANRISE H12000	<ul style="list-style-type: none"> • Path Mode: Multi • Displays as "12000".
HP SANRISE H10000	<ul style="list-style-type: none"> • Path Mode: Multi • Displays as "10000".
HP SANRISE H1024/H128	<ul style="list-style-type: none"> • Path Mode: Multi • Displays as "1024" and "128".
HP SANRISE H512/H48	<ul style="list-style-type: none"> • Path Mode: Multi • Displays as "512" and "48".
HP SANRISE H256	<ul style="list-style-type: none"> • Path Mode: Multi • Displays as "256".
HP XP7	<ul style="list-style-type: none"> • Path Mode: Multi • Displays as "XP7".
HP StorageWorks P9500	<ul style="list-style-type: none"> • Path Mode: Multi • Displays as "P9500".
HP XP24000	<ul style="list-style-type: none"> • Path Mode: Multi • Displays as "24000".
HP XP20000	<ul style="list-style-type: none"> • Path Mode: Multi • Displays as "20000".
HP XP12000	<ul style="list-style-type: none"> • Path Mode: Multi • Displays as "12000".
HP XP10000	<ul style="list-style-type: none"> • Path Mode: Multi • Displays as "10000".
HP XP1024/XP128	<ul style="list-style-type: none"> • Path Mode: Multi • Displays as "1024" and "128".
HP XP512/XP48	<ul style="list-style-type: none"> • Path Mode: Multi • Displays as "512" and "48".
HP XP256	<ul style="list-style-type: none"> • Path Mode: Multi

Storage System	Reference
	<ul style="list-style-type: none"> Displays as "256".
HP StorageWorks Enterprise Virtual Array 3000/4000/5000/6000/8000	<ul style="list-style-type: none"> Path Mode: Single Displays as "EVA".
SVS200	<ul style="list-style-type: none"> Path Mode: Multi Displays as "SVS200".

External path configurations — direct and switch

This chapter describes recommendations for setting up direct and switch external path configurations.

Direct connection

The following figure shows redundant paths in a direct connection configuration. External storage system ports, "WWN A" and "WWN B", are connected to the local system ports, "CL1-A" and "CL2-A" (which are specified as external ports). For greater redundancy, Path 2, the alternate path, uses ports of a different cluster in both the local and external storage systems.

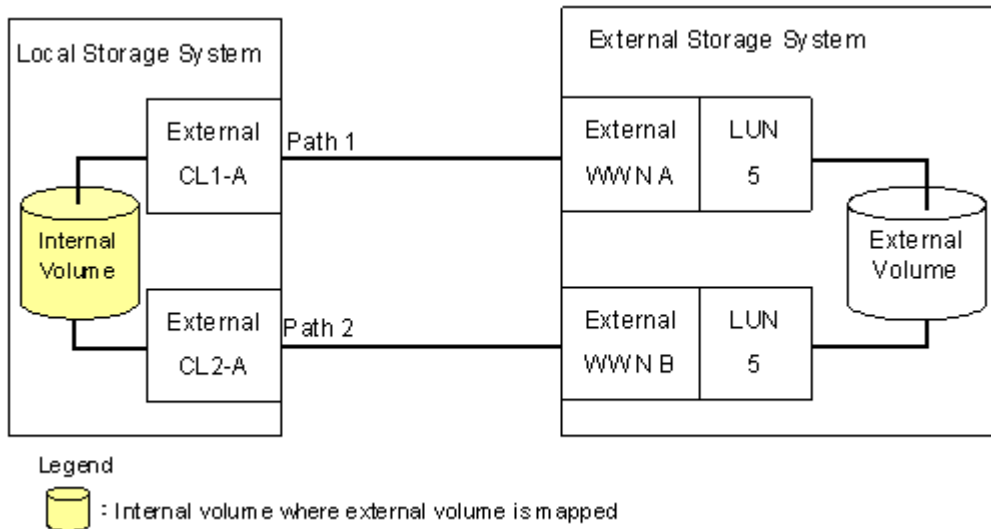

Switch connection

The following figure shows redundant paths with switches. Ports in the local system are connected to ports in the external system through the switch. The paths use ports of different clusters for increased redundancy.

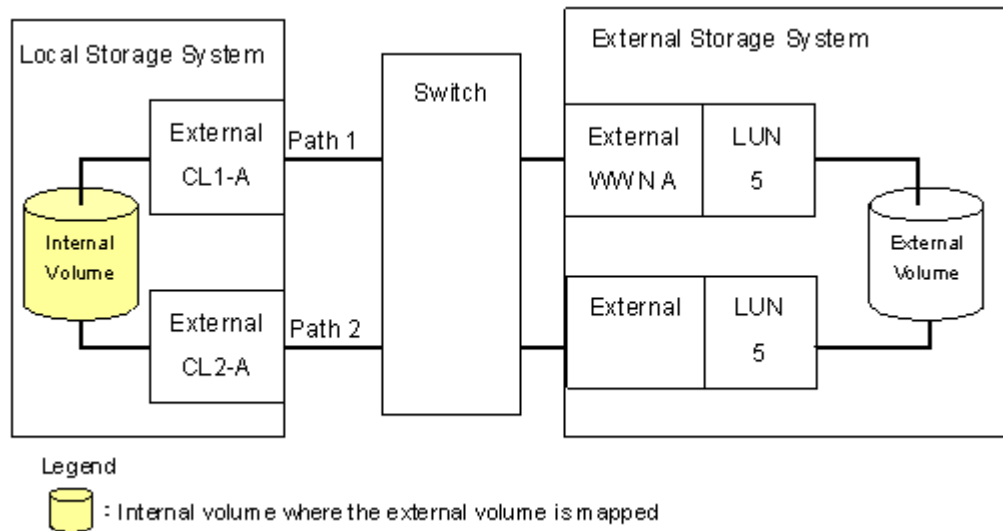

Mapping policy

The mapping policy is a list of settings that are required for mapping external volumes. Setting mapping policies before you perform a mapping operation is the easiest way to configure your mapping settings. Policies are already available and the user can change the default value. See [Editing external volume policies \(settings\) on page 5-2](#) to review the settings and edit them if desired.

VSP G1000 software supported for external volumes

You will use Virtual Storage Platform G1000 storage software products and functionality to manage and manipulate data in your mapped volumes: for example, Virtual LVI/Virtual LUN, TrueCopy, LUN Manager, and so on.

This chapter describes requirements and restrictions for the Hitachi software supported for use with external volumes including:

- [Cache Residency Manager](#)
- [Thin Image](#)
- [Dynamic Provisioning, Dynamic Tiering, and Thin Image](#)
- [Global-active device](#)
- [Local replication software](#)
- [LUN Manager and Configuration File Loader](#)
- [Performance Monitor](#)
- [Remote replication software](#)
- [SNMP Agent](#)
- [Virtual LVI/LUN \(VLL\)](#)

Cache Residency Manager

Review the following restrictions for using external volumes with Cache Residency Manager:

- If you set bind mode, the Cache Residency Manager operation requires a cache of twice as much capacity as the user data area of the mapped volume.
- If the **Cache Mode** is set to **Disable**, you cannot specify Bind mode for an external volume. You can specify the **Cache Mode** setting before, during, or after mapping. See [Editing external volume policies \(settings\) on page 5-2](#) for more information.

Thin Image

Mapped volumes can be used in pairs for Thin Image, with the following restrictions:

- Both internal and external volumes cannot be used together in the same pool.
- All external volumes in a pool must use the same **Cache Mode** setting.

After you map and format an external volume, it is ready to use as a pair volume. The following figure shows an example of an external volume used as a Pool-Vol.

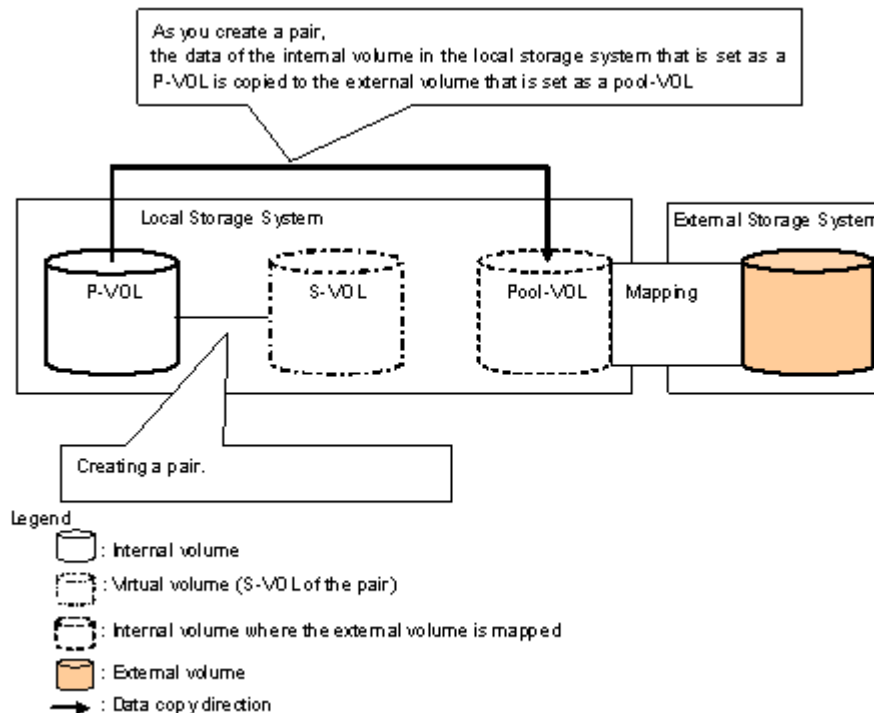

Dynamic Provisioning, Dynamic Tiering, and Thin Image

Mapped external volumes can be used as pool volumes for Dynamic Provisioning, Dynamic Provisioning for Mainframe, Dynamic Tiering, Dynamic Tiering for Mainframe, and Thin Image.

- A mapped volume that is used as a pool volume must use OPEN-V emulation for open systems and 3390-V emulation for mainframe systems.
- If you are using a Thin Image pool, all external volumes in the same pool must use the same **Cache Mode** setting. For more information about this setting, see [Cache use and external storage performance on page 2-6](#).

Global-active device

Mapped external volumes can be used as the global-active device quorum disk. They cannot be used as global-active device pair volumes.

Local replication software

Mapped volumes can be used in pairs for ShadowImage and ShadowImage for Mainframe.

After you map and format an external volume, the volume can be used as a pair volume. The following figure shows an example of an external volume used as an S-VOL.

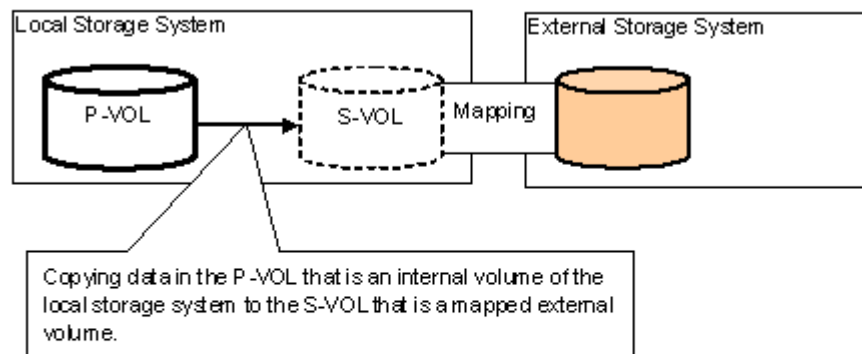

Legend

- : Internal volume
- (dashed border) : Internal volume where the external volume is mapped
- (orange) : External volume
- : Data copy direction

LUN Manager and Configuration File Loader

If you map by specifying the emulation type for open systems, you need to set the LU path using LUN Manager for mapped volumes.

Some LUN Manager operations can be performed using spreadsheets and the Configuration File Loader function.

When using external volumes, you can use Configuration File Loader for the following operations:

- Set the LU path definition for an external volume (add, delete, or change LU paths).
- Set an external volume as a command device (add or delete the setting).
- The following two actions are not supported:
 - Setting the channel adapter (CHA) mode, host group, and WWN for the external port
 - When an external volume is mapped through an external port, the port setting operation of the topology is not available.

Performance Monitor

Performance Monitor can be used to display monitoring information for mapped external volumes.

Remote replication software

You can use mapped external volumes with the following remote replication software:

- TrueCopy
- TrueCopy for Mainframe
- Universal Replicator
- Universal Replicator for Mainframe

After you map and format an external volume, the volume can be used as a pair volume. The following figures show examples of an external volume used as an S-VOL.

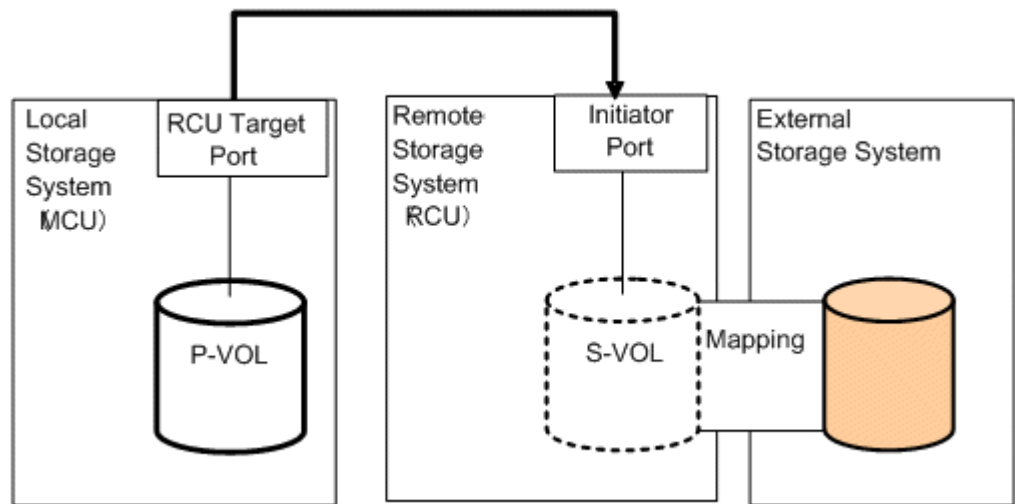

Figure 3-1 UR and URz example using a mapped external volume

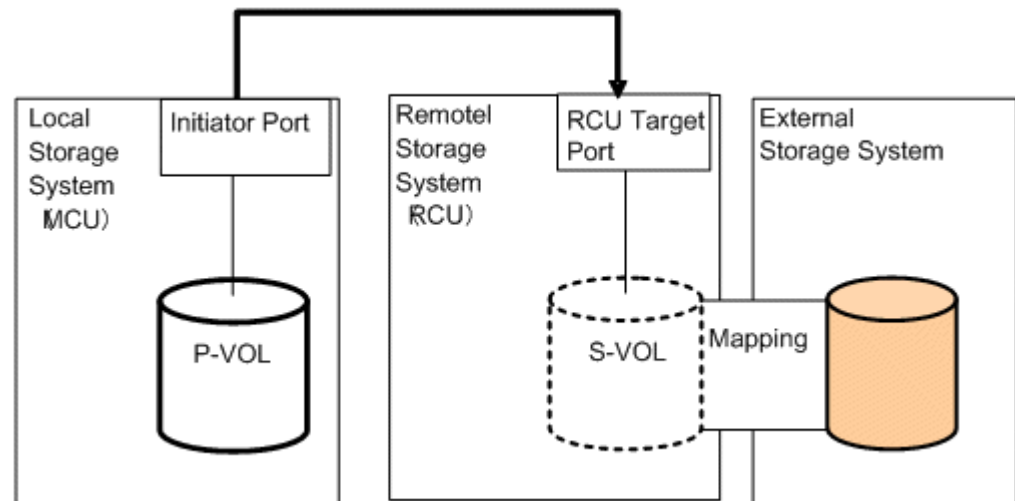

Figure 3-2 TC and TCz example using a mapped external volume

SNMP Agent

The SNMP Agent can display information about both the mapped external volume and the External port.

Virtual LVI/LUN (VLL)

For mainframe external volumes, use the Virtual LVI function to perform the Write to Control Blocks operation immediately after mapping. See the *Hitachi Virtual Storage Platform G1000 Provisioning Guide for Mainframe Systems* for information.

If you create LDEVs from an external volume using the Virtual LVI or Virtual LUN function, the **Cache Mode** setting of the created LDEVs is the same as the **Cache Mode** setting of the mapped external volume.

Setting up external volumes

You set up ports and external paths, map the external volume, then begin using it with native storage on the VSP G1000. This chapter describes external volume setup procedures and information, including configuring ports and port attributes, mapping external volumes, preparing mapped volumes for use, and using mapped volumes. It also discusses recognizing the local system from the external system.

- [Setup workflow](#)
- [Setting port attributes on the local system](#)
- [Setting up ports on the external system](#)
- [Limitations on mapping an external volume](#)
- [Mapping an external volume](#)
- [Preparing mapped volumes for use](#)
- [Using mapped volumes](#)
- [Recognizing the local system from the external system](#)

Setup workflow

You must complete all planning and preparation tasks before beginning the Universal Volume Manager setup process. Before you begin setting up Universal Volume Manager, consult the topics in [Planning workflow on page 2-2](#) to make sure you have completed all planning tasks.

Set up external volumes by performing the following tasks:

Procedure:

1. Set up ports on the local and external storage systems. See the following:
 - [Setting port attributes on the local system on page 4-2](#)
 - [Setting up ports on the external system on page 4-4](#)
2. To edit mapping settings prior to the mapping operation, see [Editing external volume policies \(settings\) on page 5-2](#). You can also make changes during the mapping operation or accept the default settings.
3. Map the external volume as the internal volume.
You can read the existing data of a mapped internal volume from the local storage system. The following settings are required:
 - Set the emulation type of the external volume to OPEN-V.
 - Set the number of LDEVs per external volume to 1.For more information, see [Mapping an external volume on page 4-5](#).
4. After the external volume is successfully mapped, perform the one of the following depending on the emulation type of the volume:
 - For mainframe emulations, format the volume or perform the Write to Control Blocks operation using Virtual LVI. See the *Hitachi Virtual Storage Platform G1000 Provisioning Guide for Mainframe Systems*.
 - For OPEN-system emulation, define LU paths to a host using LUN Manager. See the *Hitachi Virtual Storage Platform G1000 Provisioning Guide for Open Systems*.

See also:

[Recognizing the local system from the external system on page 4-13.](#)

Setting port attributes on the local system

The port attribute of a local storage system connected to an external storage system must be specified as External. For information on setting up ports, see the user guide of your external storage system.

Prerequisites

- Before changing the port's attribute, release any LU paths that are assigned to the port.
- Ports that have RCU target and Initiator attributes and that are no longer used for remote copy operations, can be changed to External.

- For more information about setting up the external path, see [Planning external paths and path groups on page 2-14](#).

Required role

- Storage Administrator (System Resource Management)

Procedure:

1. Open the **Ports/Host Groups** window.
In the Hitachi Command Suite:
 - a. On the **Resources** tab, click **Storage Systems**, and then expand **All Storage Systems**.
 - b. Expand the target storage system and click **Ports/Host Groups**.
 In Device Manager - Storage Navigator:
 - a. Click **Storage Systems**, and then expand the **Storage Systems** tree.
 - b. Click **Ports/Host Groups**.
2. In the **Ports/Host Groups** window, click the **Ports** tab.
3. Select the desired port, and then click **Edit Ports**.

Number of Ports	Target	28	Initiator	7
	RCU Target	7	External	6
	Total	48		

Port ID	Internal WWN	Speed	Security	Type	Address (Loop ID)	Fabric	Connection Type	Attribute	Resource Group Name (ID)
CL1-A	50060E800775E400	10Gbps	Disabled	FCoE	EF (0)	ON	P-to-P	Initiator	meta_resource ...
CL3-A	50060E800775E420	10Gbps	Disabled	FCoE	E8 (1)	ON	P-to-P	Initiator	meta_resource ...
CL5-A	50060E800775E440	10Gbps	Disabled	FCoE	E4 (2)	ON	P-to-P	Target	meta_resource ...
CL7-A	50060E800775E460	10Gbps	Disabled	FCoE	E2 (3)	ON	P-to-P	Target	meta_resource ...
CL1-B	50060E800775E401	10Gbps	Disabled	FCoE	E1 (4)	ON	P-to-P	RCU Tar...	meta_resource ...
CL3-B	50060E800775E421	10Gbps	Disabled	FCoE	E0 (5)	ON	P-to-P	RCU Tar...	meta_resource ...
CL5-B	50060E800775E441	10Gbps	Disabled	FCoE	DC (6)	ON	P-to-P	Target	meta_resource ...
CL7-B	50060E800775E461	10Gbps	Disabled	FCoE	DA (7)	ON	P-to-P	Target	meta_resource ...
CL1-E	50060E800775E404	Auto(-)	Disabled	Fibre	CD (16)	OFF	P-to-P	Initiator	meta_resource ...
CL3-E	50060E800775E424	Auto(-)	Disabled	Fibre	CC (17)	OFF	P-to-P	RCU Tar...	meta_resource ...
CL1-F	50060E800775E405	Auto(-)	Disabled	Fibre	C9 (20)	OFF	FC-AL	Target	meta_resource ...
CL3-F	50060E800775E425	Auto(-)	Disabled	Fibre	C7 (21)	OFF	FC-AL	Target	meta_resource ...
CL1-C	50060E800775E402	Auto(-)	Enabled	Fibre	B2 (32)	OFF	FC-AL	Target	meta_resource ...
CL3-C	50060E800775E422	Auto(-)	Disabled	Fibre	B1 (33)	OFF	FC-AL	External	meta_resource ...
CL5-C	50060E800775E442	Auto(-)	Disabled	Fibre	AE (34)	OFF	FC-AL	External	meta_resource ...
CL1-D	50060E800775E403	Auto(-)	Disabled	Fibre	AD (35)	OFF	FC-AL	RCU Tar...	meta_resource ...
CL3-D	50060E800775E423	Auto(-)	Disabled	Fibre	AB (37)	OFF	FC-AL	External	meta_resource ...
CL5-D	50060E800775E443	Auto(-)	Disabled	Fibre	AA (38)	OFF	FC-AL	Target	meta_resource ...
CL7-D	50060E800775E463	Auto(-)	Disabled	Fibre	A9 (39)	OFF	FC-AL	Target	meta_resource ...
CL1-G	50060E800775E406	Auto(-)	Enabled	Fibre	98 (48)	OFF	FC-AL	Target	meta_resource ...

4. In the **Edit Ports** window, select **External** in the **Port Attribute** box.

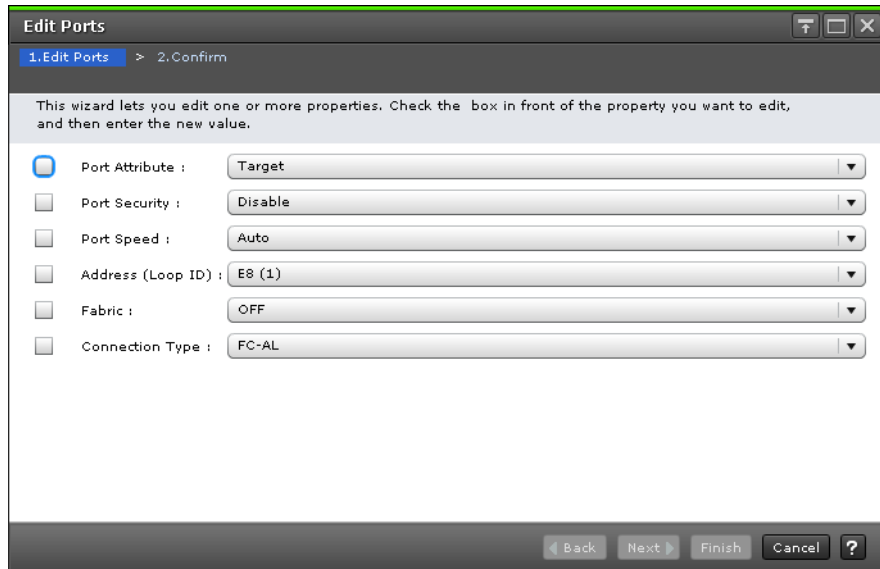

5. For help with other settings, see the *Hitachi Virtual Storage Platform G1000 Provisioning Guide for Mainframe Systems* or *Hitachi Virtual Storage Platform G1000 Provisioning Guide for Open Systems*.
6. When ready, click **Finish**.
7. In the **Confirm** window, review all settings, then either click to accept the task name or enter a new name, and then click **Apply**.

Related topics

- **Edit Ports wizard** in the *Hitachi Virtual Storage Platform G1000 Provisioning Guide for Open Systems*

Setting up ports on the external system

Make sure the external system ports you use have enough capacity for the read/write workload planned for the external volumes. See the discussion in [External paths on page 2-14](#) for more information.

The following are general steps for setting up external-system ports. Refer to the documentation for the external system for full information.

Procedure:

1. Configure the topology settings according to the configuration of the connection (fabric or loop).
2. Set the data transfer speed according to the connection configuration.
3. Set parameters for the ports on the external system as required for connecting with VSP G1000. For your specific external system, see [Appendix A, Supported external storage systems on page A-1](#).

If you do not find your external system in the section, see <http://www.hds.com/products/storage-systems/specifications/supported->

[external-storage.html](#) to make sure your system is supported and then refer to the documentation for the system's ports.

4. Define LUNs and present them on the port on the external system.

Limitations on mapping an external volume

You must set the port attribute to "External port" before you can map the external volume as an internal volume. Make sure to check the capacity requirements of the external volume you intend to map as an internal volume.

Following are the limitations on mapping an external volume:

- You cannot access data that is stored in an area that exceeds the maximum capacity of the external volume. For example, if you map 100GB of an external volume as 70GB of the internal volume, 30GB of the external volume cannot be accessed from the local storage system side.
- You cannot map an external volume which does not meet the minimum capacity requirement. For example, you cannot map 10GB of the external volume as an internal volume with a minimum capacity requirement of 30GB.

Mapping an external volume

Set the attribute of the port used for Universal Volume Manager to the external port, and then you can map the external volume as an internal volume.

Prerequisites

- Attributes set for the external volume before mapping, such as port security, LUN security, Volume Retention Manager attributes are discarded when the external volume is mapped. If the original attributes are required, reset them in the local storage system after mapping.
- When the external volume is a command device, it is mapped as a remote command device. For important information about mapping command devices, see [Appendix B, Remote command devices on page B-1](#).
- Before you map the external volume, determine whether any application is using the volume. If you find any, stop them before mapping. For example, before mapping a command device, make sure CCI commands are not being executed.



Note: When you create an LDEV at the same time that you map an external volume, you cannot select the following LDEV numbers:

- Numbers already in use.
- Numbers already assigned to another emulation group (which consists of LDEVs that are grouped every 32 LDEV numbers).
- Numbers not assigned to the user.

- Model/serial number and LDEV ID/virtual LDEV ID of the storage system and the virtual storage machine do not match in the mainframe volume or the interim volume that you create.

For emulation groups, see *Hitachi Virtual Storage Platform G1000 Provisioning Guide for Open Systems* or *Hitachi Virtual Storage Platform G1000 Provisioning Guide for Mainframe Systems*. To determine whether the LDEV number can be assigned, click the **View LDEV IDs** button in the **Add External Volumes** window when you map the external volume.

Required role

- Storage Administrator (Provisioning)

Procedure:

1. Open the **External Storage** window.
In the Hitachi Command Suite:
 - a. On the **Resources** tab, click **Storage Systems**, and then expand **All Storage Systems**.
 - b. Expand the target storage systems, right-click **External Storage**, and then select **System GUI**.In Device Manager - Storage Navigator:
 - a. Click **Storage Systems**, and then expand the **Storage Systems** tree.
 - b. Click **External Storage**.
2. On the **External Storage Systems** tab, click **Add External Volumes**.
3. In the **Add External Volumes** window, add the external volume by clicking either **By New External Path Group** or **By Existing External Path Group**.

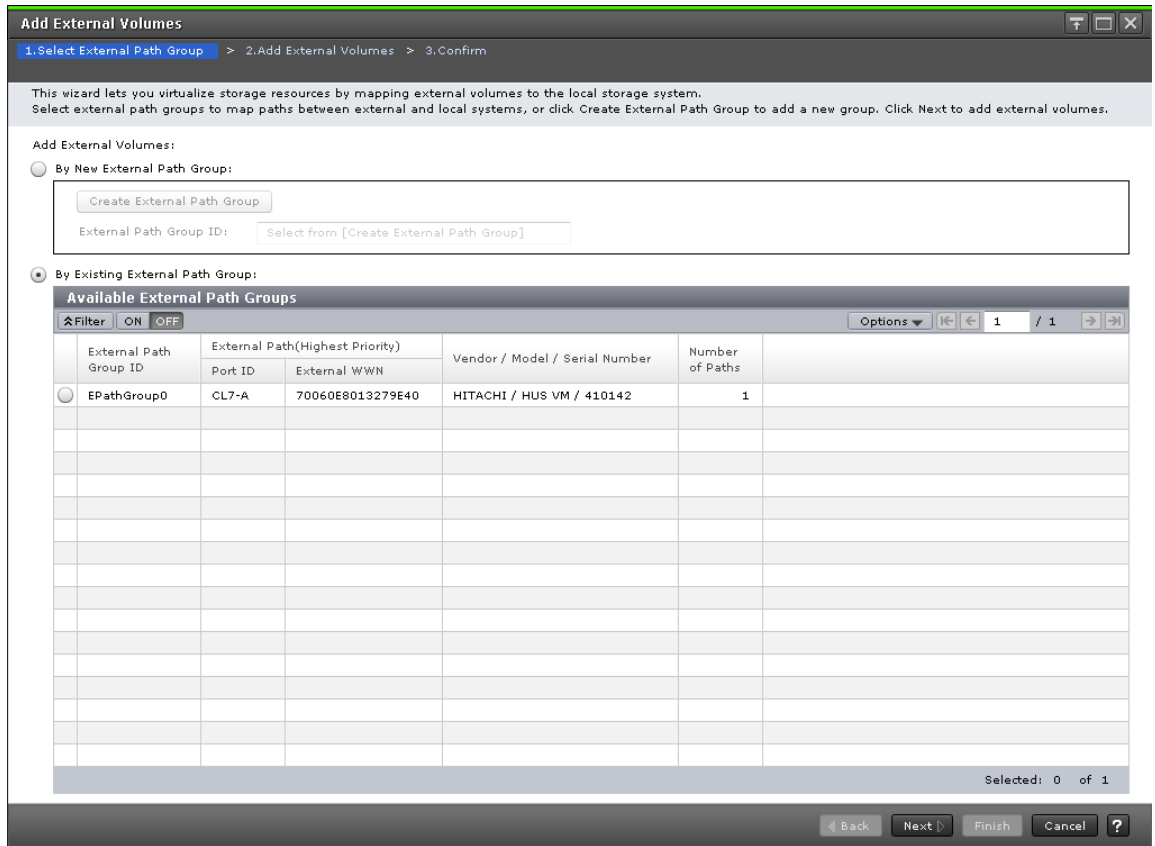

To add the external volume **By New External Path Group**:

- a. Click **Create External Path Group**.
- b. In the **Create External Path Group** window, enter the following:

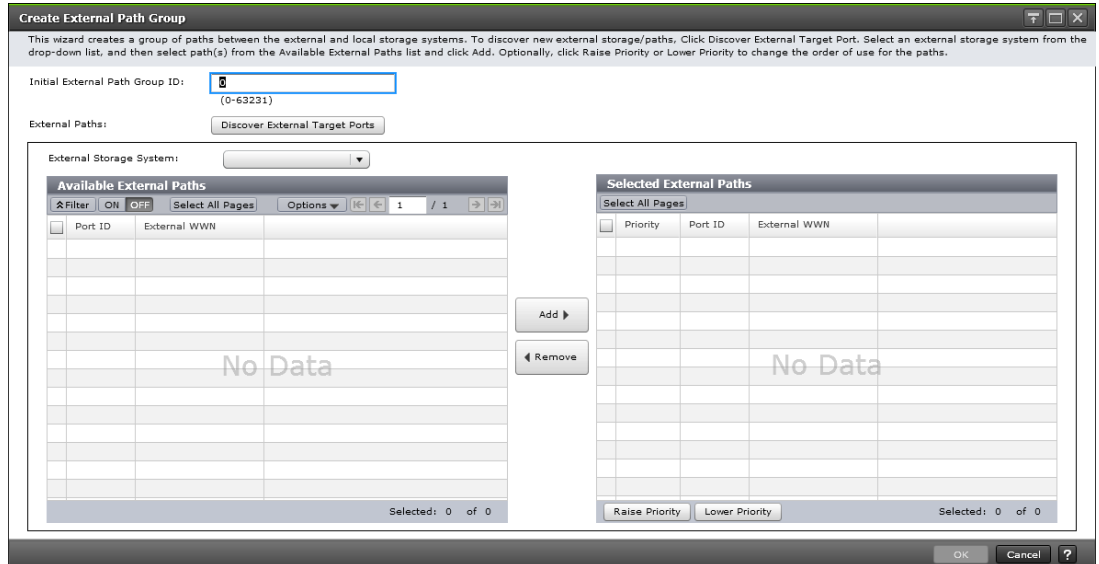

- o **Initial External Path Group ID.** The storage system searches IDs from the initial ID you specify in ascending order and allocates an ID that can be used. The range can be from 0 to 63,231. 0 is the default.
- o **External Paths.** If you do not see the port or WWN you want in the **Available External Paths** box, click **Discover External Target**

Ports. In the new window, select the desired ports and click **Add**, then click **OK**.

- o **External Storage System.** If the external system is not selected, scroll down the list and select it.
 - o **Available External Paths.** Select the desired port IDs and click **Add**, then click **OK**.
- c. Set the priority for a path by selecting it and clicking **Raise Priority** or **Lower Priority**.
- d. Click **OK**.

To add the external volume **By Existing External Path Group**:

- a. Click **By Existing External Path Group**.
 - b. If you have not identified the external storage system that you want to connect the external path to, click the storage system button and select the system.
 - c. In the **Available External Paths** list, select the desired path group. Path groups consist of the external paths previously set up and prioritized.
 - d. Click **Next**.
4. In the **Add External Volumes** window's **Discovered External Volumes** box, select the desired external volumes.

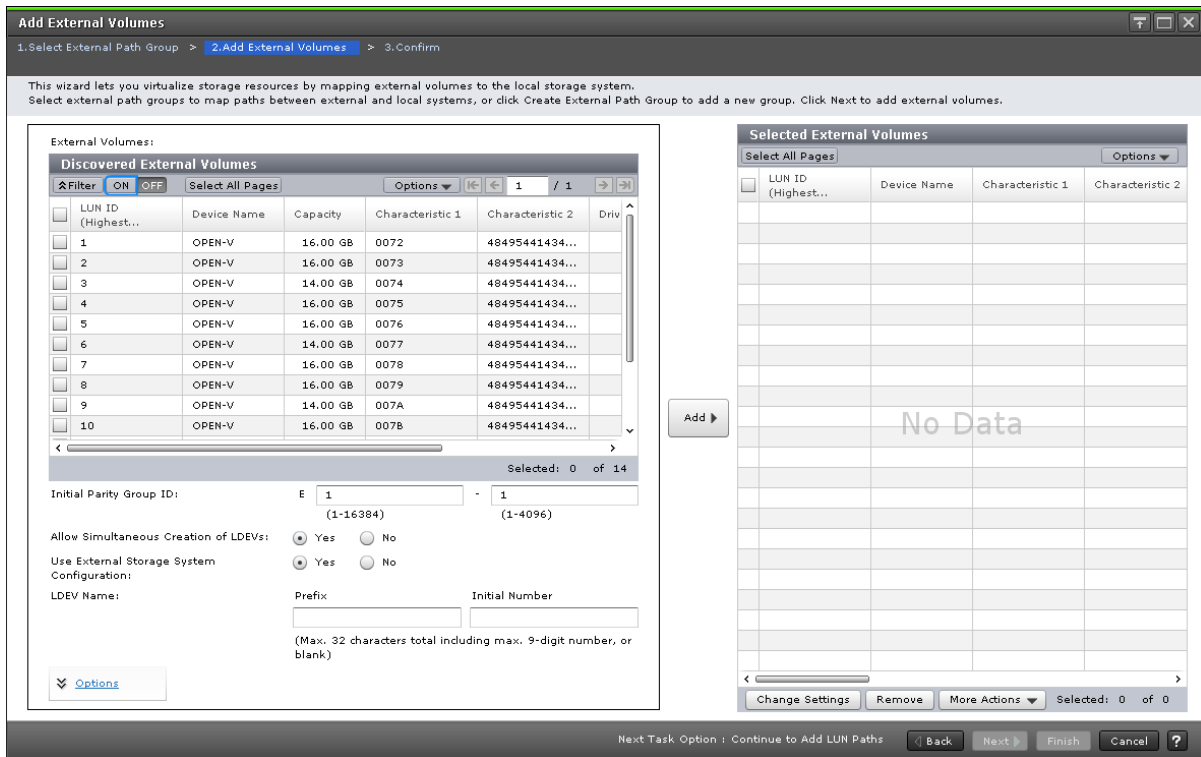

5. In **Initial Parity Group ID**, enter an external volume group number and sequential number. You can use the group number to place similar external volumes in a group. For example, you could assign the same external volume group number to volumes used for a copy function. The range is from 1 - 1 to 16384 - 4096.

6. In **Allow Simultaneous Creation of LDEVs**, select **Yes** if you want to allow the system to automatically create LDEVs in the external volume. Otherwise select **No**.
If the external volume is a command device, select **Yes** in both **Allow Simultaneous Creation of LDEVs** and **Use External Storage System Configuration**.
7. In **Use External Storage System Configuration**, if you select **Yes**, the **Base Emulation Type** is inactive so it cannot be selected and the emulation type is set based on the LDEV name of the external storage system. If you select **No**, the **Base Emulation Type** is active so it can be selected.
If the external volume is a command device, select **Yes** in both **Allow Simultaneous Creation of LDEVs** and **Use External Storage System Configuration**.
8. In **LDEV Name**, enter the prefix character and the initial number.
If you enter a prefix character and an initial number, their combined value can be a maximum of 32 characters, including the initial number (numerical value of 9 digits or less). Note the following numbering rule:
 - 1:total 9 numbers (1,2,3,...9)
 - 08:total 92 numbers (08,09,10,...99)
 - 23:total 77 numbers (23,24,25,...99)
 - 098:total 902 numbers (098,099,100...999)
9. Click **Options** (if not already expanded). If you have previously edited mapping settings (policies), you may not want to change the options. However, review the following steps—since some fields in **Options** are affected by preceding steps.

The screenshot shows the 'Options' configuration window. At the top left, there is a blue arrow icon and the text 'Options'. Below this, the 'Initial LDEV ID:' section contains three input fields: 'LDKC' with the value '00', 'CU' with a dropdown menu showing '00', and 'DEV' with a dropdown menu showing '00'. Below these is an 'Interval' dropdown menu set to '0' and a 'View LDEV IDs' button. The 'Number of LDEVs per External Volume:' section has a text input field containing '1' and '(1)' below it. The 'Cache Partition:' section has a dropdown menu showing '0:CLPR0'. The 'Cache Mode:' section has two radio buttons: 'Enable' (unselected) and 'Disable' (selected). The 'Inflow Control:' section also has two radio buttons: 'Enable' (unselected) and 'Disable' (selected). The 'Use ALUA as Path Mode:' section has a dropdown menu showing 'Disable'. The 'Load Balance Mode:' section has a dropdown menu showing 'Normal Round-robin'. The 'MP Blade:' section has a dropdown menu showing 'Auto'.

10. In the expanded **Options** box, for **Initial LDEV ID** enter the initial LDEV ID for the external volume. The local storage system searches from this number in ascending order and allocates the next available ID. You can review used, available, and disabled LDEVs by clicking **View LDEV IDs**.
 - For **LDKC**, enter 00.
 - For **CU**, enter the CU number, which can range from 00 to FE. 00 is the default.
 - For **DEV**, enter the LDEV ID, which can range from 00 to FF. 00 is the default.
 - For **Interval**, enter an interval between LDEV IDs, which can range from 0 to 255. 0 is the default.
11. In **Initial SSID**, enter the SSID, which can range from 0004 to FFFE. 0004 is the default.
You can review the current SSIDs by clicking **View SSIDs**.
12. In **Base Emulation Type**, select the emulation type of the external volume.
If you selected **Yes** in **Allow Simultaneous Creation of LDEVs** and **No** in **Use External Storage System Configuration**, you must select an emulation type. If you selected **Yes** in both fields, **Base Emulation Type** is greyed out, and OPEN-V is automatically set.
13. In **Number of LDEVs per External Volume**, enter the number of LDEVs to be created when the volume is mapped. This field is greyed out if you selected **Yes** in **Allow Simultaneous Creation of LDEVs** and **Use External Storage System Configuration**, and **1** displays (since OPEN-V is the emulation type). See [Capacity requirements for volumes on page 2-8](#) for more information.
14. In **Cache Partition**, select the CLPR for accessing the mapped external volume.



Note: For more information about the **Cache Partition**, **Cache Mode**, and **Inflow Control** settings, see [Editing external volume policies \(settings\) on page 5-2](#).

15. In **Cache Mode**, click **Enable** to propagate write data asynchronously from cache to the external storage system. Click **Disable** to propagate data synchronously.
 - If you specify **Disable**, the Cache Residency Manager bind mode cannot be set.
 - When the external volume is a command device, **Cache Mode** for the remote command device is automatically set to **Disable** regardless of your setting.
 - Data that is not written by the host (for example, data written by pair operation) is asynchronously destaged to the external storage system regardless of the **Cache Mode** setting.
16. In **Inflow Control**, click **Enable** to limit or prevent write data from being written to cache memory when the write operation to the external volume

cannot be performed. Click **Disable** to allow write data to be written to cache.

17. In **MP Blade**, select the MP blade for the external volume. MP blade assignment should evenly distribute work across the available processors. The range is from MPB0 to MPB7. The value depends on the configuration of the device.
Select **Auto** (the default) to cause an MP blade to be automatically assigned by the system. If **Auto** cannot be selected, the MP blade with the lowest number is selected by default.
18. Click **Add**.
19. If you need to change the added volume's settings, in the **Selected External Volumes** list click the volume, click **Change Settings**, make necessary changes, and click **OK**.
20. To to add LUN paths, click **Next** in the **Add External Volumes** window. See the *Hitachi Virtual Storage Platform G1000 Provisioning Guide for Open Systems* for information.
21. Click **Finish** when ready.
22. In the **Confirm** window, review all settings, and then accept the task name or enter a one.
When you select the external volume and click **LDEV Detail**, the **External LDEV Properties** window is displayed for you to review the LDEV information.
23. In the **Confirm** window, click **Apply**.

Related topics

- [Add External Volumes wizard on page D-17](#)
- [Create External Path Group window on page D-43](#)
- [Change Settings window on page D-45](#)
- [View External LUN Properties window on page D-47](#)
- [External LDEV Properties window on page D-54](#)
- [Discovery Result Detail window on page D-55](#)
- [Table B-1 Restrictions on remote command device on page B-3](#)
- **View SSIDs** in the *Hitachi Virtual Storage Platform G1000 Provisioning Guide for Open Systems* or the *Hitachi Virtual Storage Platform G1000 Provisioning Guide for Mainframe Systems*
- **Edit SSIDs** in the *Hitachi Virtual Storage Platform G1000 Provisioning Guide for Open Systems* or the *Hitachi Virtual Storage Platform G1000 Provisioning Guide for Mainframe Systems*

Preparing mapped volumes for use

After external volumes are mapped to the local storage system, you can take the following steps to prepare the volumes for use.

Required role

- Storage Administrator (Provisioning)

Procedure:

1. Depending on emulation type, perform one of the following:
 - For mainframe emulation, the status of the mapped volume becomes **Blockade** after mapping. Format the volume using Virtual LVI to change to a normal status.
For zero-formatted external volumes, use Virtual LVI to perform the **Write to Control Blocks** operation to restore the volume. Even if you formatted the volume from the external storage side after recovering the mapped volume, you must perform the **Write to Control Blocks** operation of the VLL feature after the formatting. For instructions, see the *Hitachi Virtual Storage Platform G1000 Provisioning Guide for Mainframe Systems*.
 - For open-system emulation, the status of the mapped volume automatically becomes **Normal**. If you need to initialize the data area of the mapped volume, format the volume using Virtual LUN.
2. For both emulation types, set an LU path from a Target port to the internal volume, as shown in the following figure.
The LU path enables host I/O to the mapped volume.

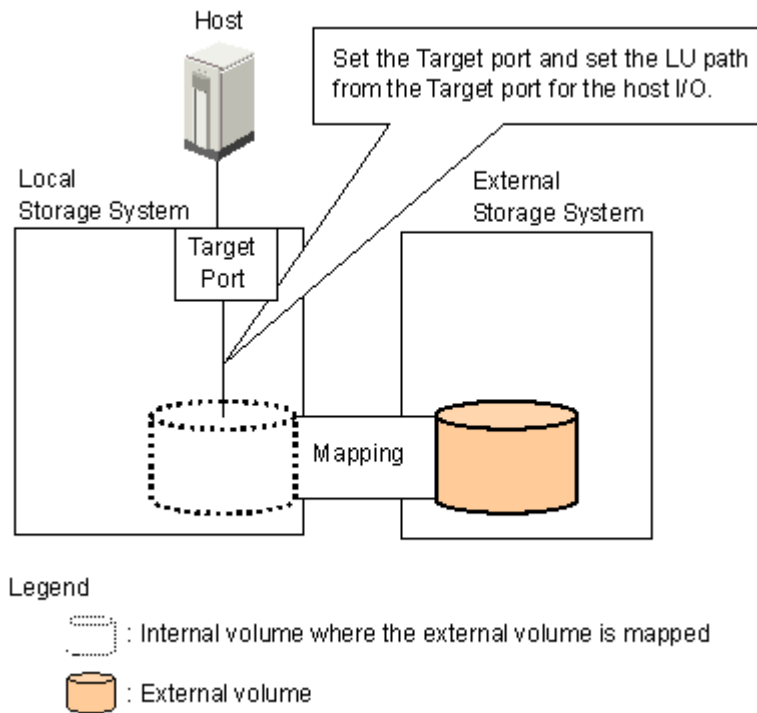

Using mapped volumes

When external volumes are mapped and ready for use, you can perform the operations supported by Universal Volume Manager. Review supported software products and operations in [Chapter 3, VSP G1000 software supported for external volumes on page 3-1](#).



Note: A mapped external volume can be accessed only from the local system. Do not access the volume from a host connected to the external storage system.

Also, do not use external storage system functions to access the mapped external volume, including copy functions.

Recognizing the local system from the external system

Though the local and external systems are connected, the external system may not recognize the local system. If desired, you can try to make this happen by performing the Discover External Target Ports operation. See [Adding an external path to an existing path group on page 5-11](#) for instructions. If the path does not become mapped after 15 minutes, though, the external system might not be able to recognize the local system.

Monitoring and maintenance

This chapter describes monitoring, editing, and maintenance instructions for external volumes, paths, and systems.

- [Monitoring external volumes and paths](#)
- [Editing external volume policies \(settings\)](#)
- [Changing MP blade for external volume](#)
- [Changing path mode to ALUA mode \(Enable or Disable\)](#)
- [Changing I/O mode for external storage systems](#)
- [Editing external WWN settings](#)
- [Path maintenance](#)
- [Disconnecting external systems and volumes](#)
- [Reconnecting external systems and volumes](#)
- [Deleting an external volume mapping](#)
- [Powering off and on local, external storage systems](#)

Monitoring external volumes and paths

You can view system details about mapped external volumes, the ports used, and the external paths.

Required role

- Storage Administrator (Provisioning)

Procedure:

1. Open the **External Storage** window.
In the Hitachi Command Suite:
 - a. On the **Resources** tab, click **Storage Systems**, and then expand **All Storage Systems**.
 - b. Expand the target storage systems, right-click **External Storage**, and then select **System GUI**.In Device Manager - Storage Navigator:
 - a. Click **Storage Systems**, and then expand the **Storage Systems** tree.
 - b. Click **External Storage**.
2. On the **External Storage Systems** tab, click the link for an external system.
3. On the **External Path Groups** tab, click the link for a path group.
4. On the **Mapped Volumes** tab, select one or more external volumes, and then select **View External LUN Properties**.

Related topics

- [View External LUN Properties window on page D-47](#)

Editing external volume policies (settings)

When you map an external volume to an internal volume, mapping policies are used. To change the mapping policies, you need to edit the default mapping settings. You can change default mapping settings without affecting the settings in previously mapped volumes.

To reset the values for previously mapped volumes, go to the **Edit External Volumes** window and change settings volume by volume.

The settings and their functions are described in the following bullets. To skip to the procedure, see [Editing mapping policies for external volumes on page 5-4](#).

- **Base Emulation Type**
 - Specify OPEN-V to use existing data in the external volume from VSP G1000.

- If you use an emulation type other than OPEN-V, the volume requires a specific area for management data. This results in a volume capacity after mapping that is less than the actual external volume capacity. See [Capacity requirements for volumes on page 2-8](#) for more information about capacity and about calculating the capacity of your external volume.
- **Cache Mode.** I/O to and from the local storage system always uses cache. Write operations are always backed up in duplex cache. The **Cache Mode** setting specifies whether write data from the host is written to the external volume asynchronously (**Enable**) or synchronously (**Disable**).
 - If **Enable** is specified: After receiving the data into the local system's cache memory, the system signals the host that the I/O operation has completed, and then asynchronously destages the data to the external volume.
 - When **Disable** is specified (the default): After synchronously writing the data to the external volume, the local system signals the host that an I/O operation has completed.

For further discussion, see [Cache use and external storage performance on page 2-6](#).

- **Cache Partition.** Cache memory can be partitioned by using Virtual Partition Manager to configure a cache logical partition (CLPR) for the mapped volumes. Cache logical partitions are often used to limit cache-use by accessing slower external storage volumes.
Hitachi strongly recommends that you place external storage array groups in a CLPR other than CLPR0. See *Hitachi Virtual Partition Manager User Guide* for detailed information on CLPR.
- **Inflow Control.** When the write operation to the external volume cannot be completed, **Inflow Control** specifies whether the write operation to cache memory is limited (**Enable**) or continued (**Disable**).
 - **Enable:** The write operation to cache is limited and I/O from the host is not accepted. Limiting the write operation prevents the accumulation of data that cannot destage to cache memory.
 - **Disable** (default): I/O sent from the host during the retry operation is written to cache memory. When write operations to the external volume are again possible, data in cache memory is written to the external volume (all data is destaged).
- **ALUA mode (Use ALUA as Path Mode:Enable or Disable).**
In the local storage system, you can select whether **ALUA mode** is used as the path mode. If ALUA is supported in the profile information of the external storage, **Enable** is used by default. Otherwise, **Disable** is used. For information on **ALUA mode**, see [Supported external systems path mode for external volumes on page 2-16](#).
- **Load Balance Mode.** Select **Depend on the selected external volume(s)**, **Normal Round-robin**, **Extended Round-robin**, or **Disable** as a **Load Balance Mode** for the external storage system. By default, **Normal Round-robin** is used. However, when the product name of the

storage system is displayed as (generic), **Depend on the selected external volume(s)** is used by default..

If **Single** is set as the **Path Mode** or **Disable** is set for **Use ALUA as Path Mode, Load Balance Mode** cannot be specified.

- **Depend on the selected external volume(s)**: If **Enable** is set for **ALUA Settable** on the external volume, **Normal Round-robin** is set for **Load Balance Mode** automatically. If **Disable** is set for **ALUA Settable**, **Disable** is set for **Load Balance Mode** automatically.
- **Normal Round-robin**: I/O is distributed to several paths on which I/O operation is enabled for the external storage system.
- **Extended Round-robin**: I/O is distributed to several paths on which I/O operation is enabled for the external storage system. For sequential I/O, the external volume is divided into sections at regular intervals. In this case, the same path is used for I/O within the same section which reduces the frequency of I/O distribution.
- **Disable**: As in **Single** mode, I/O operation is performed using the path that has the highest priority of all paths on which I/O operation is enabled for the external storage system.

Editing mapping policies for external volumes

Required role

- Storage Administrator (Provisioning)

Procedure:

1. Open the **External Storage** window.
In the Hitachi Command Suite:
 - a. On the **Resources** tab, click **Storage Systems**, and then expand **All Storage Systems**.
 - b. Expand the target storage systems, right-click **External Storage**, and then select **System GUI**.In Device Manager - Storage Navigator:
 - a. Click **Storage Systems**, and then expand the **Storage Systems** tree.
 - b. Click **External Storage**.
2. In the **External Storage** window, click the **External Paths** tab.
3. On the **External Paths** tab, select a path group.
4. Click **More Actions** and select **Edit Policies**.
5. In the **Edit Policies** window, make whatever changes are required to the external volume settings.
6. Click **Apply**.

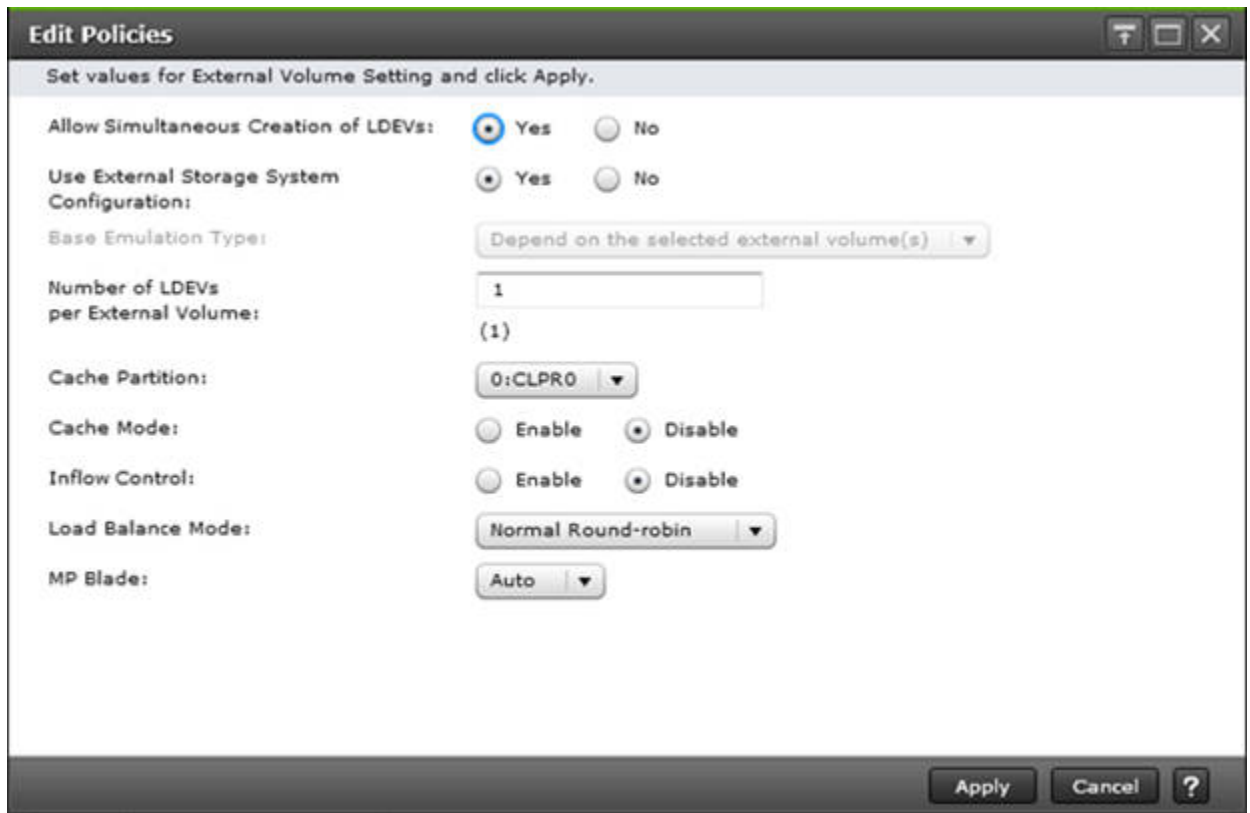

Note: You can also edit **Cache Mode** and **Inflow Control** for individual external volumes. In , Device Manager - Storage Navigator, select an external volume in the **Mapped Volumes** tab. Then click **Edit External Volumes**.

Related topics

- [Edit Policies window on page D-28](#)

Changing MP blade for external volume

Required role

- Storage Administrator (Provisioning)

Procedure:

1. Open the **External Storage** window.
In the Hitachi Command Suite:
 - a. On the **Resources** tab, click **Storage Systems**, and then expand **All Storage Systems**.
 - b. Expand the target storage systems, right-click **External Storage**, and then select **System GUI**.
 In Device Manager - Storage Navigator:

- a. Click **Storage Systems**, and then expand the **Storage Systems** tree.
- b. Click **External Storage**.
2. On the **External Storage Systems** tab, click the link for an external system.
3. On the **External Path Groups** tab, click the link for a path group.
4. On the **Mapped Volumes** tab, select one or more external volumes, and then select **More Actions > Assign MP Blade**.
5. In the **Assign MP Blade** window, select the desired MP blade.

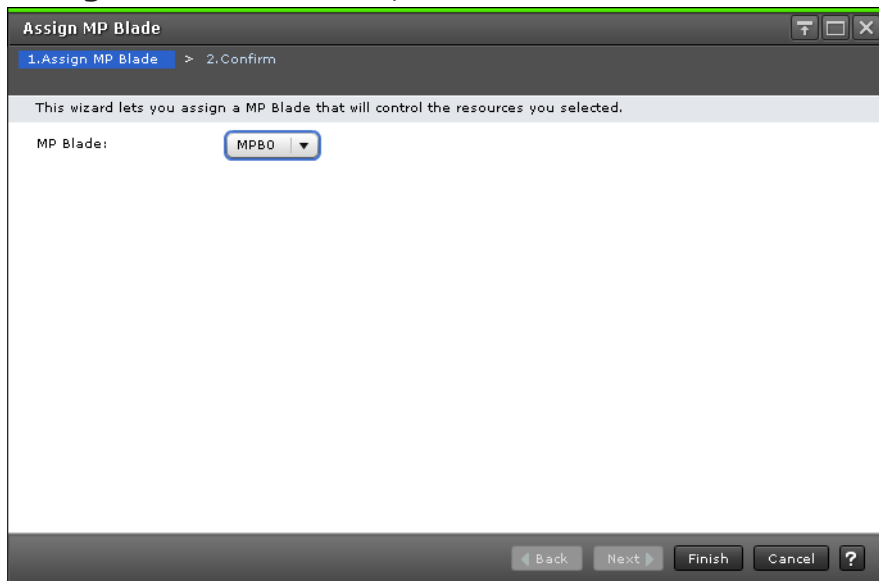

The current setting for the external volume is displayed, unless you have selected multiple external volumes with different values. Then the field is blank.

The choices you see are dependent on the configuration of the device. They range from **MPB0** to **MPB7**.



Note: MP blade assignment should be set to evenly distribute work across all the available processors.

Selecting **Auto** allows the system to assign the blade.

6. Click **Finish**.
7. In the **Confirm** window, review the settings, accept the task name or enter a new one, and then click **Apply**.

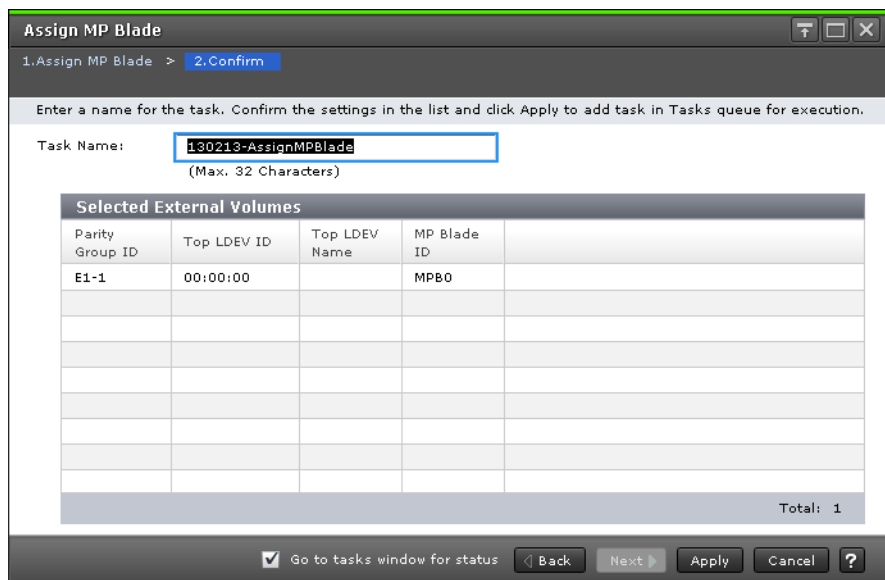

Changing path mode to ALUA mode (Enable or Disable)

You can select whether ALUA mode is used as the path mode. See [Supported external systems path mode for external volumes on page 2-16](#).

Prerequisites

- The external storage system must support ALUA. If **Enable** is set for **ALUA Settable** on the external volume, **Enable** is set for **Use ALUA as Path Mode** automatically. If **Disable** is set for **ALUA Settable**, **Disable** is set for **Use ALUA as Path Mode** automatically.

Required role

- Storage Administrator (Provisioning)

Procedure:

- Open the **External Storage** window.
In the Hitachi Command Suite:
 - On the **Resources** tab, click **Storage Systems**, and then expand **All Storage Systems**.
 - Expand the target storage systems, right-click **External Storage**, and then select **System GUI**.
 In Device Manager - Storage Navigator:
 - Click **Storage Systems**, and then expand the **Storage Systems** tree.
 - Click **External Storage**.
- On the **External Storage Systems** tab, click the link for an external system.
- On the **External Path Groups** tab, click the link for a path group.

4. On the **Mapped Volumes** tab, select an external volume, and then click **Edit External Volumes**.
5. On the **Edit External Volumes** window, select **Enable** or **Disable** as the **Use ALUA as Path Mode** property.
6. Click **Finish** to display the **Confirm** window.
7. Confirm the settings and enter the task name in the **Task Name** box.
8. In the **Confirm** window, click **Apply**.

Changing I/O mode for external storage systems

With Load Balance Mode settings, you can change the I/O mode for external storage systems for each of the external volumes.

This section describes operations to change the Load Balance Mode of external volumes in the Edit External Volumes window. For more information, see [Load Balance Mode on page 2-17](#).

Required role

- Storage Administrator (Provisioning)

Procedure:

1. Open the **External Storage** window.
In the Hitachi Command Suite:
 - a. On the **Resources** tab, click **Storage Systems**, and then expand **All Storage Systems**.
 - b. Expand the target storage systems, right-click **External Storage**, and then select **System GUI**.In Device Manager - Storage Navigator:
 - a. Click **Storage Systems**, and then expand the **Storage Systems** tree.
 - b. Click **External Storage**.
2. On the **External Storage Systems** tab, click the link for an external system.
3. On the **External Path Groups** tab, click the link for a path group.
4. On the **Mapped Volumes** tab, select an external volume, and then click **Edit External Volumes**.
5. On the **Edit External Volumes** window, select the **Load Balance Mode** property, and then click **Extended Round-robin**, **Normal Round-robin**, or **Disable**.
6. Click **Finish** to display the **Confirm** window.
7. Confirm the settings and enter the task name in the **Task Name** box.
8. In the **Confirm** window, click **Apply**.

Editing external WWN settings

You can change the external system's WWN port setting. However, note the following:

- If the current setting is error-free, it is best to continue using it.
- For an external volume with normal I/O, set **I/O Timeout** from 5 - 15 seconds.
- Use the external system's recommended values for other port settings.

Required role

- Storage Administrator (Provisioning)

Procedure:

1. Open the **External Storage** window.
In the Hitachi Command Suite:
 - a. On the **Resources** tab, click **Storage Systems**, and then expand **All Storage Systems**.
 - b. Expand the target storage systems, right-click **External Storage**, and then select **System GUI**.In Device Manager - Storage Navigator:
 - a. Click **Storage Systems**, and then expand the **Storage Systems** tree.
 - b. Click **External Storage**.
2. Click the **External Paths** tab.
3. On the **External Paths** tab, select **Edit External WWNs**.

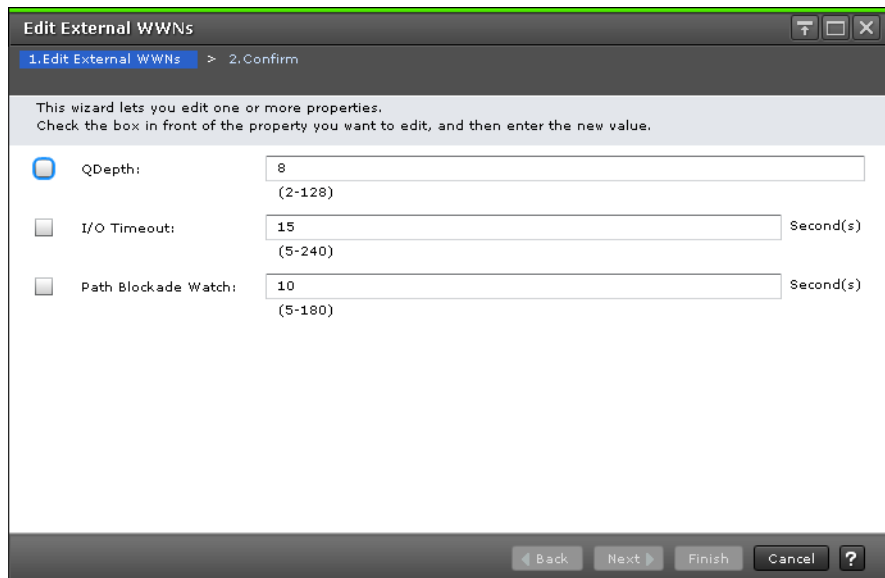

5. Click **Finish**.
6. In the **Confirm** window, review settings, accept the task name or enter a one, and then click **Apply**.

Path maintenance

You can add external paths to a path group, change a path's priority, disconnect and reconnect paths (which must be performed before removing or replacing paths), remove or replace a path, or replace all paths. The following topics provide instructions.

- [Adding an external path to an existing path group on page 5-11](#)
- [Changing external path priority on page 5-12](#)
- [Disconnecting an external path on page 5-13](#)
- [Reconnecting an external path on page 5-14](#)
- [Removing, replacing an external path on page 5-17](#)
- [Replacing all external paths on page 5-18](#)

Adding an external path to an existing path group

Required role

- Storage Administrator (Provisioning)

Procedure:

1. Open the **External Storage** window.
In the Hitachi Command Suite:
 - a. On the **Resources** tab, click **Storage Systems**, and then expand **All Storage Systems**.

- b. Expand the target storage systems, right-click **External Storage**, and then select **System GUI**.

In Device Manager - Storage Navigator:

 - a. Click **Storage Systems**, and then expand the **Storage Systems** tree.
 - b. Click **External Storage**.
2. On the **External Storage Systems** tab, click the link for an external system.
3. On the **External Path Groups** tab, select a path group.
4. Click **Edit External Path Configuration**.
5. In the **Edit External Path Configuration** window, select an external path or paths from the **Available External Paths** list and click **Add**.
If the **External Storage System** or the **External WWN** that you want is not available in the dialog box, click **Discover External Target Ports** and add the port that connects to the WWN.
6. To change the priority of external paths, click **Raise Priority** or **Lower Priority** in the **Selected External Paths** list.
7. Click **Finish**.
8. In the **Confirm** window, review settings, accept the task name or enter a new one, and then click **Apply**.

Related topics

- [Edit External Path Configuration wizard on page D-32](#)
- [Discover External Target Ports window on page D-42](#)

Changing external path priority

You can change the priority of your primary and alternate external paths, moving them higher or lower depending on your requirements. See [External paths on page 2-14](#) for more information on path priorities for Single and Multi mode.

Required role

- Storage Administrator (Provisioning)

Procedure:

1. Open the **External Storage** window.
In the Hitachi Command Suite:
 - a. On the **Resources** tab, click **Storage Systems**, and then expand **All Storage Systems**.
 - b. Expand the target storage systems, right-click **External Storage**, and then select **System GUI**.

In Device Manager - Storage Navigator:

- a. Click **Storage Systems**, and then expand the **Storage Systems** tree.
 - b. Click **External Storage**.
2. On the **External Storage Systems** tab, click the link for an external system.
3. On the **External Path Groups** tab, select a path group.
4. Click **Edit External Path Configuration**.
5. In the **Edit External Path Configuration** window, in the **Selected External Paths** list, select the desired path and click **Raise Priority** or **Lower Priority**.
6. Repeat the previous step to continue moving the path higher or lower. Move other paths as needed.
7. Click **Finish**.
8. In the **Confirm** window, review settings, accept the new task name or enter a new one, and then click **Apply**.

Related topics

- [Edit External Path Configuration wizard on page D-32](#)

Disconnecting an external path

You can disconnect all external paths connected either to a port on the local system or to a WWN on the external system. Disconnecting paths affects the external volumes mapped using the port.

An external path is disconnected for the following reasons:

- Before removing a path.
- To replace a path or switch
- To perform maintenance on a path
- To perform maintenance on the external system or volume

Prerequisites

- When you disconnect a path, make certain that alternate paths are available for mapped external volumes using the path.

Required role

- Storage Administrator (Provisioning)

Procedure:

1. Open the **External Storage** window.
In Hitachi Command Suite:
 - a. On the **Resources** tab, click **Storage Systems**, and then expand **All Storage Systems**.

- b. Expand the target storage systems, right-click **External Storage**, and then select **System GUI**.

In Device Manager - Storage Navigator:

- a. Click **Storage Systems**, and then expand the **Storage Systems** tree.
 - b. Click **External Storage**.
2. Click the **External Paths** tab.
 3. On the **External Paths** tab, select a path group.
 4. Click **Disconnect External Paths**.
 5. In the **Disconnect External Paths** window, select one of the following (illustrated in the figure below):
 - o **By Ports** to disconnect all external paths connected to the specified port in the local storage system.
 - o **By External WWNs** to disconnect all external paths connected to the specified WWNs (ports) in the external storage system.

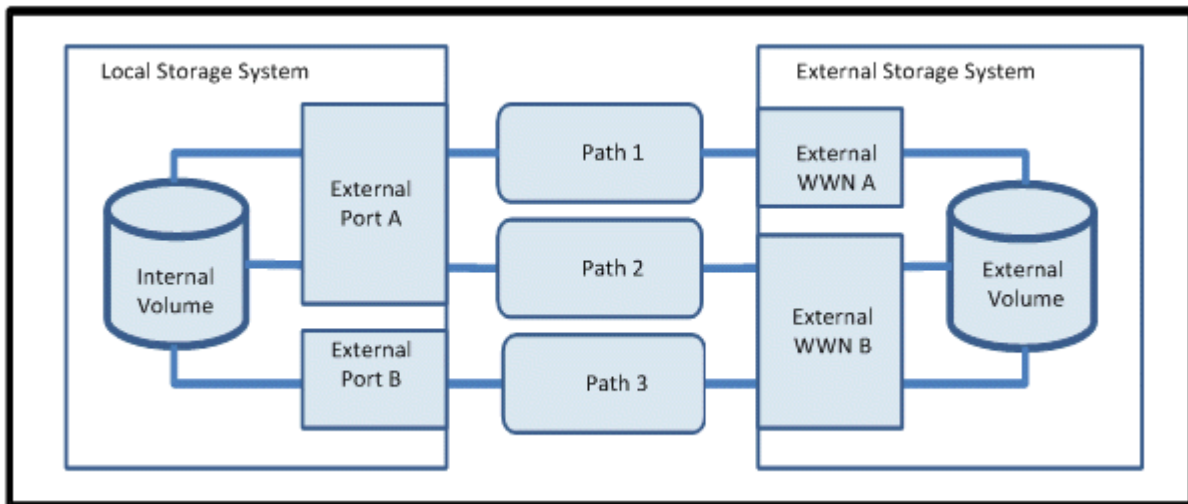

6. Click **Finish**.
7. In the **Confirm** window, review settings, accept or enter a new task name, and then click **Apply**.

Related topics

- [Edit External Path Configuration wizard on page D-32](#)

Reconnecting an external path

You can reconnect an external path that was disconnected. You reconnect paths either to a port on the local system or to a WWN on the external system. When you reconnect, original path settings are restored.

Prerequisites

- Make sure the path is in a status that can be restored.

Required role

- Storage Administrator (Provisioning)

Procedure:

1. Open the **External Storage** window.
In the Hitachi Command Suite:
 - a. On the **Resources** tab, click **Storage Systems**, and then expand **All Storage Systems**.
 - b. Expand the target storage systems, right-click **External Storage**, and then select **System GUI**.In Device Manager - Storage Navigator:
 - a. Click **Storage Systems**, and then expand the **Storage Systems** tree.
 - b. Click **External Storage**.
2. Click the **External Paths** tab.
3. On the **External Paths** tab, select a path group.
4. Click **Reconnect External Paths**.
5. In the **Reconnect External Paths** window, select one of the following:
 - **By Ports** to reconnect all external paths connected to the specified port in the local storage system.
 - **By External WWNs** to reconnect all external paths connected to the specified WWNs (ports) in the external storage system.
6. Click **Finish**.
7. In the **Confirm** window, review settings, accept the task name or enter a one, and then click **Apply**.

Related topics

- [Reconnect External Paths wizard on page D-41](#)

Changing the cache mode setting of the external volume

You can change the cache mode of the external volume in the Edit External Volumes window.

Prerequisites

Before changing the cache mode of the external volume, review each item listed in the following table.

Item to Review	Description
Cache Residency Manager and cache mode	When the bind mode is set, you cannot change the cache mode from Enable to Disable . To change the cache mode to

Item to Review	Description
	Disable , cancel the setting for Cache Residency Manager or change the cache residency mode to the priority mode.
Cache mode and pool volumes	When a volume is registered to a pool as a pool volume, the cache mode setting should be the same among all the pool volumes in the pool.
Cache mode and remote command devices	When the volume is a remote command device, you cannot change the cache mode from Disable to Enable .

Changing the cache mode

If the system cannot communicate with external volumes, the **Inflow Control** setting specifies whether the write operation to cache is limited (**Enable**) or continued (**Disable**). **Disable** is set by default. You can change the setting in the **Edit External Volumes** window. If you are using a Thin Image pool, all external volumes in the same pool must use the same **Cache Mode** setting.

Required role

- Storage Administrator (Provisioning)

Procedure:

- Open the **External Storage** window.
In the Hitachi Command Suite:
 - On the **Resources** tab, click **Storage Systems**, and then expand **All Storage Systems**.
 - Expand the target storage systems, right-click **External Storage**, and then select **System GUI**.
 In Device Manager - Storage Navigator:
 - Click **Storage Systems**, and then expand the **Storage Systems** tree.
 - Click **External Storage**.
- On the **External Storage Systems** tab, click the link for an external storage system.
- On the **External Path Groups** tab, click the link for a path group.
- On the **Mapped Volumes** tab, select an external volume, and then click **Edit External Volumes**.
- On the **Edit External Volumes** window, select the **Inflow Control** property, and then click **Enable** or **Disable**.
- Click **Finish** to display the **Confirm** window.
- Confirm the settings and enter the task name in the **Task Name** box.
- In the **Confirm** window, click **Apply**.

Related topics

- [Edit External Volumes wizard on page D-29](#)
- [Supported external systems path mode for external volumes on page 2-16](#)

Removing, replacing an external path

You can remove a path so it is no longer available to the external volume. You remove a path to replace it with another external path or to perform maintenance on the physical link.



Note: If all external paths are not removed before detaching a channel adaptor, the channel adaptor cannot be detached.

Prerequisites

- Before removing a path, make sure it is disconnected. See [Disconnecting an external path on page 5-13](#) for instructions.

Procedure:

1. Open the **External Storage** window.
In the Hitachi Command Suite:
 - a. On the **Resources** tab, click **Storage Systems**, and then expand **All Storage Systems**.
 - b. Expand the target storage systems, right-click **External Storage**, and then select **System GUI**.In Device Manager - Storage Navigator:
 - a. Click **Storage Systems**, and then expand the **Storage Systems** tree.
 - b. Click **External Storage**.
2. On the **External Storage Systems** tab, click the link for an external system.
3. On the **External Path Groups** tab, select a path group.
4. Click **Edit External Path Configuration**.
5. In the **Edit External Path Configuration** window, in the **Selected External Paths** list, select the path to be removed and click **Remove**.

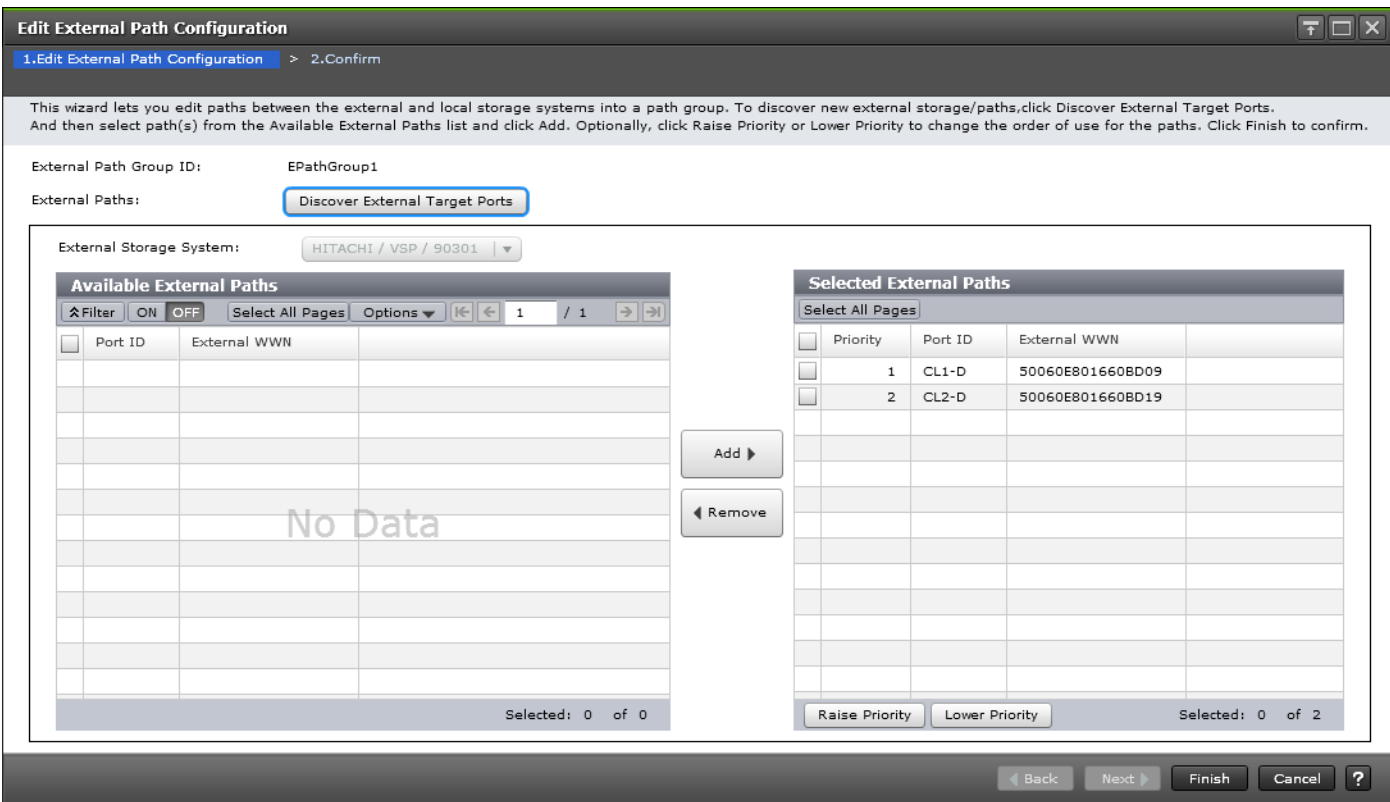

The external path is deleted from the **Selected External Paths** list.

6. Click **Finish**.
7. In the **Confirm** window, review settings, accept or enter a new task name, and then click **Apply**.
If you are replacing the path, see [Adding an external path to an existing path group on page 5-11](#).

Related topics

- [Edit External Path Configuration wizard on page D-32](#)

Replacing all external paths

You can replace the primary and alternate paths used by an external volume. Doing this requires one path to remain in Normal status at all times, which is shown in the following figure.

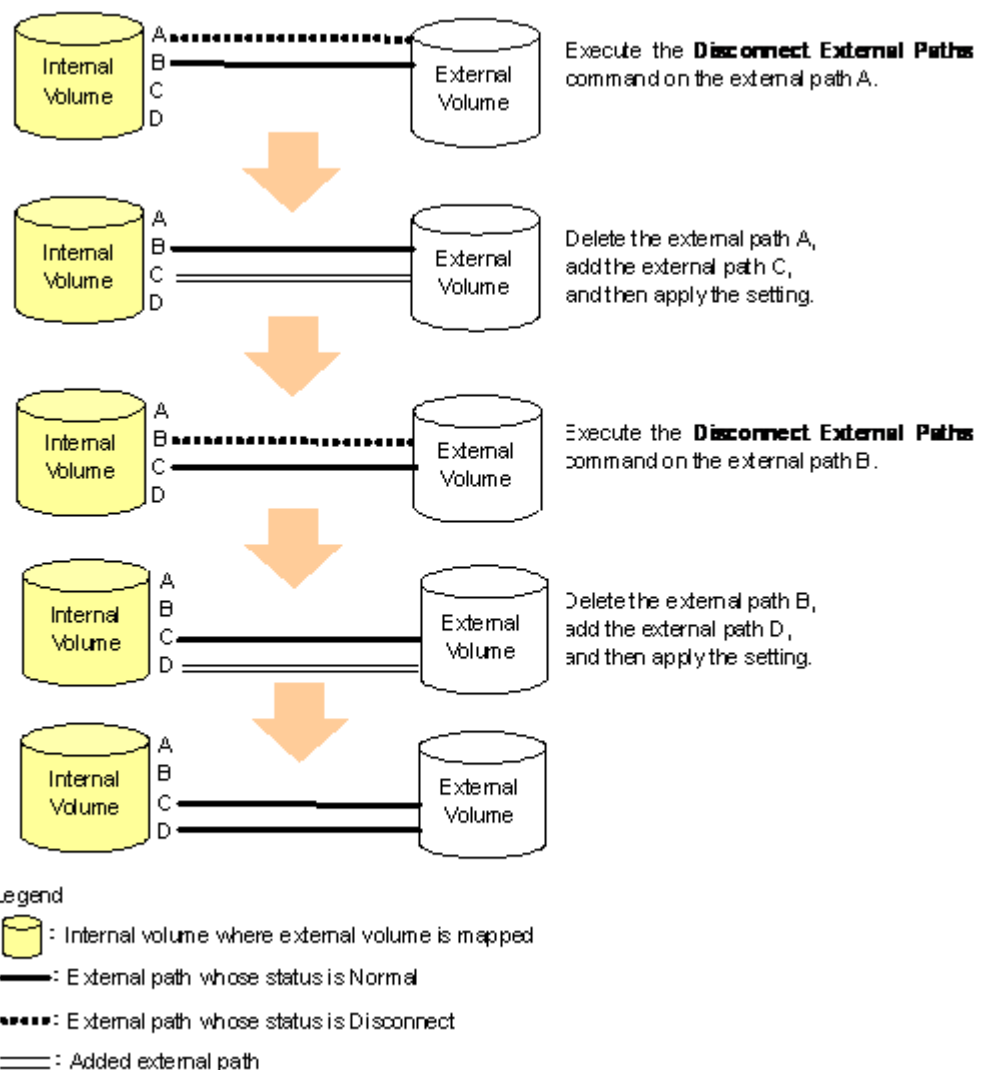

This procedure uses the illustration above.

Procedure:

1. Disconnect **external path A**. See [Disconnecting an external path on page 5-13](#).
2. Disconnect the cable for **external path A**, then remove it. See [Removing, replacing an external path on page 5-17](#).
3. Make sure the cable for **external path C** is connected, and then add this path to an existing path group. See [Adding an external path to an existing path group on page 5-11](#).

When **external path C** status is Normal, then both **external path B** and **external path C** are set, and you can replace the next path.

4. Disconnect **external path B**.
5. Disconnect the cable for **external path B**, then remove it.

6. Make sure the cable for **external path D** is connected, and then add this path to an existing path group.
When **external path D** status is Normal, then both **external path C** and **external path D** are set. The paths have all been replaced.

Disconnecting external systems and volumes

You can disconnect a single mapped external volume, or all the mapped volumes in an external system. You disconnect all volumes by disconnecting the system itself.

You disconnect a volume or system in order to perform the following operations:

- Turn off the power supply of the local or external storage system
- Delete an external volume's mapping
- Access a mapped external volume or volumes from the external storage system

When you disconnect a volume or volumes, they stop accepting host I/O, and all data in cache is written to the volumes (data is destaged). Also, the mapping settings are preserved. When the volumes are reconnected, they are assigned the same settings.

Prerequisites

Before disconnecting volumes or systems, processes must be resolved or stopped, as described in the following table.

Activity in the external volume	Required operation
I/O to the external volume from the open system host is in progress.	Stop I/O to the volume and un-mount the volume from the host. Host I/O is forcibly stopped if you disconnect when I/O is in progress.
The external volume is online from the mainframe host.	Stop the host I/Os to the volume and perform the Vary Offline operation.
The external volume includes LDEVs used in pair operations with copy software products.*	Delete the pair. You can disconnect without deleting a ShadowImage or ShadowImage for Mainframe pair when pair status is PSUE or Suspend/SUSPER.
The external volume includes LDEVs registered to a Thin Image data pool.	Delete Thin Image data pool.
The external volume includes LDEVs registered to a Dynamic Provisioning pool volume (DP-VOL).	Perform the following operations on DP-VOLs associated with the external volume: <ul style="list-style-type: none"> • Stop using the DP-VOLs. • Block the DP-VOLs using Virtual LVI/Virtual LUN.

Activity in the external volume	Required operation
The external volume includes LDEVs for which Volume Migration processing is in progress.	Delete the migration plans.
The global-active device quorum disk is used.	Delete the quorum disk settings.
* Copy software products are: ShadowImage, ShadowImage for Mainframe, Universal Replicator, Universal Replicator for Mainframe, TrueCopy, TrueCopy for Mainframe, Thin Image, and global-active device.	

Disconnecting an external storage system, all mapped volumes

When you disconnect an external system, the mapped external volumes in the system are also disconnected. This is the primary method for disconnecting all the mapped volumes in an external system.

Before disconnecting a mapped volume, review [Prerequisites on page 5-20](#).

Required role

- Storage Administrator (Provisioning)

Procedure:

1. Open the **External Storage** window.
In the Hitachi Command Suite:
 - a. On the **Resources** tab, click **Storage Systems**, and then expand **All Storage Systems**.
 - b. Expand the target storage systems, right-click **External Storage**, and then select **System GUI**.
 In Device Manager - Storage Navigator:
 - a. Click **Storage Systems**, and then expand the **Storage Systems** tree.
 - b. Click **External Storage**.
2. On the **External Storage Systems** tab, select a path group.
3. Click **Disconnect External Storage Systems**.
4. In the **Disconnect External Storage Systems** window, review the volumes that will be disconnected, then click **Apply**.

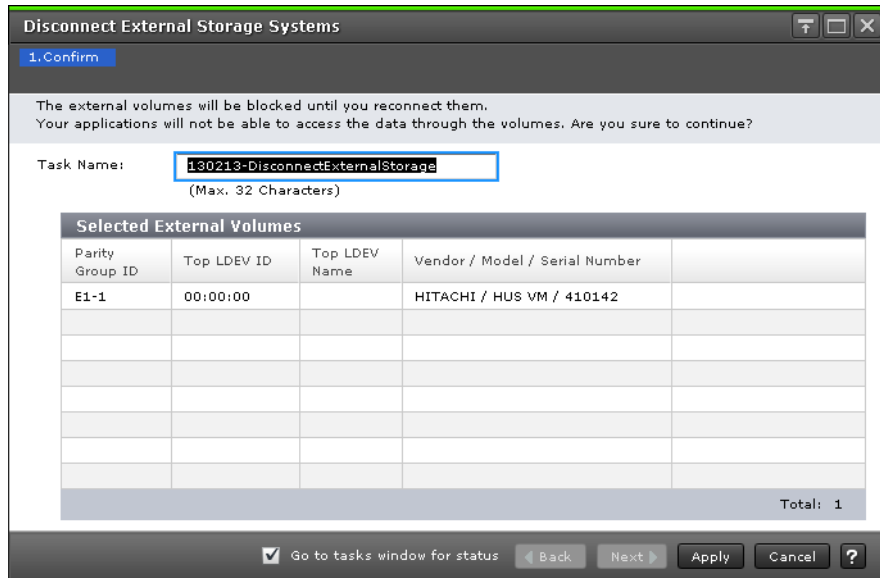

5. In the **Confirm** window, click **Apply** again.

When you finish the procedure, external volume's status displays as **Cache Destage**, even if there is no data left in the cache. You can click **Refresh View** to update the status. When processing is completed, the volumes' status changes to **Disconnect**.

Related topics

- [Disconnect External Storage Systems window on page D-50](#)

Disconnecting a single mapped volume

Before disconnecting a mapped volume, review [Prerequisites on page 5-20](#).

Required role

- Storage Administrator (Provisioning)

Procedure:

1. Open the **External Storage** window.
In the Hitachi Command Suite:
 - a. On the **Resources** tab, click **Storage Systems**, and then expand **All Storage Systems**.
 - b. Expand the target storage systems, right-click **External Storage**, and then select **System GUI**.
 In Device Manager - Storage Navigator:
 - a. Click **Storage Systems**, and then expand the **Storage Systems** tree.
 - b. Click **External Storage**.

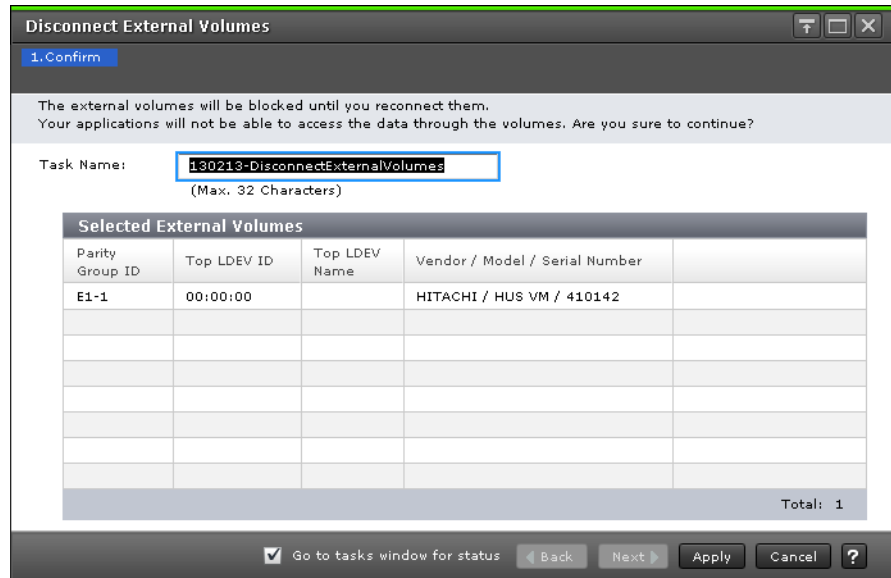

7. Click **Apply** in the **Confirm** window.

When you finish the procedure, the external volume's status displays as **Cache Destage**, even if there is no data left in the cache. You can click **Refresh View** to update the status. When processing is completed, the volumes' status changes to **Disconnect**.

Related topics

- [Disconnect External Volumes window on page D-51](#)

Reconnecting external systems and volumes

After you disconnect an external volume or volumes, you can start using them again by reconnecting.

When you reconnect a volume or system, the preserved mapping settings and path status are compared to the current status of the volume. If the status and settings match, the volume status changes to Normal and the volume is available for I/O operations. However, if the external volume is not ready to resume I/O operations, the status of the disconnected volume is **Blockade**. If this occurs, see [General troubleshooting on page 6-2](#).

Reconnecting an external storage system and all mapped volumes

When you reconnect an external system, all the mapped external volumes in the system are also reconnected. This is the primary method for reconnecting the disconnected volumes in an external system.

Required role

- Storage Administrator (Provisioning)

To reconnect a disconnected external system and mapped volumes

- Storage Administrator (Provisioning)

Procedure:

1. Open the **External Storage** window.
In the Hitachi Command Suite:
 - a. On the **Resources** tab, click **Storage Systems**, and then expand **All Storage Systems**.
 - b. Expand the target storage systems, right-click **External Storage**, and then select **System GUI**.In Device Manager - Storage Navigator:
 - a. Click **Storage Systems**, and then expand the **Storage Systems** tree.
 - b. Click **External Storage**.
2. On the **External Storage Systems** tab, click the link for the storage system with the volume to be reconnected.
3. On the **External Path Groups** tab, click the link for a path group.

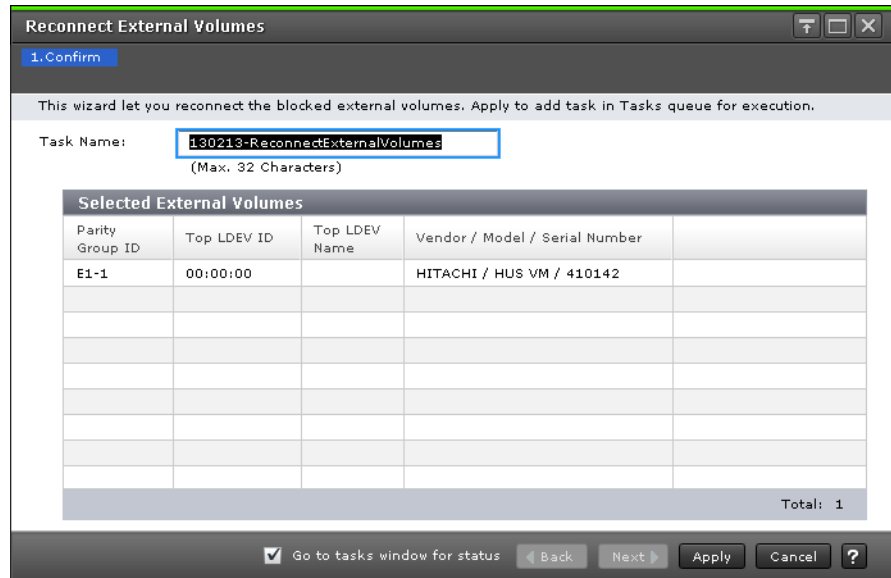

7. Click **Apply** in the **Confirm** window.
8. When you finish the procedure, the external volume status displays as **Checking**, and then **Normal**. If the volume cannot be resumed because the mapped settings and the external volume status are not in sync, the status becomes **Blockade**.

Related topics

- [Reconnect External Volumes window on page D-49](#)

Deleting an external volume mapping

You can delete the mapping for an external volume. The data in the external volume is not deleted.

Prerequisites

- If you disconnect the external volume or volumes, before you delete them, all the data in the cache memory is written to the external volume. However, you can delete a volume without disconnecting, meaning that data in cache is not destaged to the external volume.
- You cannot delete a mapping while the external volume is used in the following:
 - TrueCopy, Universal Replicator, ShadowImage, Thin Image, or global-active device.
 - A reserved volume for ShadowImage or Volume Migration.
 - A pool-VOL
 - A Quorum Disk
- For command devices, stop the application using the external volume as a command device.

7. For **Have you already disconnected external volume of above table?**, click one of the following:
 - **Yes** if you have already disconnected the volumes.
 - **No** if you have not disconnected the volumes.
8. If you clicked **No** in the previous step, then, for **Do you want to execute Delete External Volumes operation without writing the cache data to the volumes?**, click **Yes** or **No**.
9. Click **Finish**.
10. In the **Confirm** window, review settings and accept the task name shown or enter a new one. When satisfied click **Apply**.

Related topics

- [Delete External Volumes wizard on page D-37](#)

Powering off and on local, external storage systems

You must temporarily halt Universal Volume Manager functionality before powering off external storage systems. When the systems are powered on, all functions restart.

The instructions in these topics should be closely followed.

- Complete all prerequisites.
- Follow the specified order of operations exactly.
 - When powering off both local and external systems, the local system must be powered off first, followed by the external system.
 - To power on both systems, the external system must be powered on first, followed by the local system.

Requirements for external storage system maintenance

You must disconnect the external system and delete external volume mapping before making changes to the external system. After you have completed the changes, you reconnect the system and remap the external volume.

You must remove and remap the external volume before making any of the following changes to the external system:

- Changing WWNs of target ports that connect to the local storage system
- Changing the serial number of the external system
- Changing LUNs of volumes in the external system
- Reducing the volume capacity of the external volume
- Modifying a host that is directly connected to a external storage system.

It is not necessary to delete the volumes that are mapped to the local storage system before changing WWNs that are connected to the local storage system.

Procedure:

Changing the WWNs of the external storage system without deleting the external volume mapping

1. Change the WWN of the external storage.
See the *Hitachi Virtual Storage Platform G1000 Provisioning Guide for Open Systems* and the *Hitachi Virtual Storage Platform G1000 Provisioning Guide for Mainframe Systems* for detailed procedures.
Changing the WWN blocks the external path that uses the target port with a WWN that has been changed.
2. Add an external path between the local storage system and target port with a WWN that has been changed
3. Delete the external path that was blocked in step 1.

Before deleting external volume mapping, make sure that the volume has no LU paths and is not part of a copy pair. See [Deleting an external volume mapping on page 5-29](#) for instructions.

Powering off the external storage system

Required role

- Storage Administrator (Provisioning)

Procedure:

1. Stop read and write I/O to the mapped external volume.
2. If the external volume is defined as a DP-VOL in the internal system, use the steps listed in the following procedure to block all DP-VOLs for maintenance :
 - a. Click **Pools** in the **Storage Systems** tree.
 - b. In the tree, select the pool to be blocked.
 - c. Select the **Virtual Volumes** tab.
 - d. Click **Select All Pages**.
 - e. On the menu bar, click **Actions, Logical Device**, and then **Block LDEVs**.
 - f. In the **Block LDEVs** window, confirm the settings and enter the task name in the **Task Name** box.
 - g. Click **Apply** in the **Confirm** window.
3. Disconnect the external storage system. See [Disconnecting external systems and volumes on page 5-20](#) for instructions.
4. Perform the procedure for powering off the external storage system.

Related topics

- **Block LDEVs window** in the *Hitachi Virtual Storage Platform G1000 Provisioning Guide for Open Systems*

Powering on the external storage system

Required role

- Storage Administrator (Provisioning)

Procedure:

1. Power on the external storage system.
2. Reconnect the external system. See [Reconnecting external systems and volumes on page 5-25](#) for instructions.
3. If the external volume was defined as a DP-VOL in the local system, use the steps listed in the following procedure to restore all blocked DP-VOLs:

To restore all DP-VOLs in the pool

- a. Click **Pools** in the **Storage Systems** tree.
- b. In the tree, select the pool to be restored.
- c. Select the **Virtual Volumes** tab.
- d. Click **Select All Pages**.
- e. On the menu bar, click **Actions, Logical Device**, and then **Restore LDEVs**.
- f. In the **Restore LDEVs** window, confirm the settings and enter the task name in the **Task Name** box.
- g. Click **Apply** in the **Confirm** window.

Related topics

- **Restore LDEVs window** in the *Hitachi Virtual Storage Platform G1000 Provisioning Guide for Open Systems*

Powering off the local storage system

Prerequisites

You do not need to disconnect the external system when powering off only the local system. However, if you do disconnect the external system, then when you power on the local system again, access to the external system remains disabled until you reconnect it.

Procedure:

1. Stop read and write I/O to the local storage system.
2. Perform all necessary operations for powering off the local system.

Split pairs that use external volumes. For information on pairsplit operations, see the user guide for the relevant software.

3. Confirm that the status of each external volume is **Normal** or **Disconnect**.
4. Perform all necessary operations to power off the local system.
5. Turn off the power supply to the local storage system.
Data in local cache memory is written to the external volume when the local system is powered off (in other words, all data is destaged).
6. When you are ready, make sure that the external system is powered on, and then power on the local system.
Resync all pairs. For information on pairsync operations, see the user guide for the relevant software.
7. Start read or write I/O to the local storage system.

Powering off both storage systems

Procedure:

1. Stop read or write I/O to the local storage system.
2. Split all pairs using external volumes (pairsplit operation). For information on the pairsplit operation, see the user guide for the relevant software.
3. Confirm that the status of each external volume is **Normal** or **Disconnect**.
4. Power off the local storage system.
5. After the power supply of the local system is completely powered off, power off the external system.

Powering on both storage systems

Procedure:

1. Power on the external system.
2. After the power supply of the external system is completely powered on, power on the local system.
3. Resume use of the mapped external volume.
4. Start read or write I/O to the local storage system.

Troubleshooting

This chapter describes troubleshooting information.

- [Contacting the Hitachi Data Systems customer support](#)
- [General troubleshooting](#)
- [Troubleshooting external path status](#)
- [Troubleshooting path errors for specific storage systems](#)
- [Troubleshooting port and volume discovery problems](#)

Contacting the Hitachi Data Systems customer support

If you need to contact Hitachi Data Systems customer support, provide as much information about the problem as possible, including:

- The circumstances surrounding the error or failure
- The content of any error messages displayed on the host systems
- The content of any error messages displayed on Device Manager - Storage Navigator
- The Device Manager - Storage Navigator configuration information (Use the Dump Tool to get this information)
- The service information messages (SIMs), including reference codes and severity levels, displayed by Device Manager - Storage Navigator

The HDS customer support staff is available 24 hours a day, seven days a week. If you need technical support, log on to the HDS Support Portal for contact information: <https://hdssupport.hds.com>

General troubleshooting

Check the following table for the problem. After resolving an error, retry the operation.

Symptom	Possible causes and troubleshooting steps
Storage Navigator cannot access the external volume.	<ul style="list-style-type: none">• An error occurred in the switch, or the switch is off.• The cable between the local and external system is not connected properly.• The external volume was deleted in the external system.• An error occurred in the external volume.• The path is changed in the external system.• The port attribute in the local storage system is changed.• Topology information is not properly set.
The external volume cannot be mapped.	<ul style="list-style-type: none">• The number of mapped volumes exceeds the maximum number (63,232) available for the local storage system.• There are not enough LDKC:CU:LDEV numbers available for external volume mapping.
The external path is blocked.	<ol style="list-style-type: none">1. See the preceding problem, "Device Manager - Storage Navigator cannot access the external volume". If the problem persists after correcting any errors, continue to step 2.2. Confirm that the cable between the local and external system is connected properly.

Symptom	Possible causes and troubleshooting steps
	<ol style="list-style-type: none"> 3. If the cable is properly connected, disconnect it and then reconnect. After 30 seconds, check the path status. 4. If the path is not restored, contact Hitachi Data Systems customer support.
Action is required for a path status in the View External LUN Properties dialog box.	See Troubleshooting external path status on page 6-4 .
The volume in the external system cannot be found even after port discovery or volume discovery was performed.	Follow any instructions given in the error message or messages and then retry the operation. If the problem persists, see Troubleshooting port and volume discovery problems on page 6-12 .
The external volume is blocked.	<ul style="list-style-type: none"> • All external paths are blocked (paths are not connected). • The external volume is not set to Read/Write. • The external volume is blocked by an error.
The status of the external volume is Blockade .	<p>When errors occur in all external paths, the local storage system changes the status of the external volume to Blockade.</p> <ul style="list-style-type: none"> • Reconnect the volume or storage system. • If the volume's status still does not change to Normal, restore the path as described in the problem above, "The external path is blocked", and then reconnect the volume again.
The ? sign displays in the LUN ID (Highest Priority) column of the Discovered External Volumes table in the Add External Volumes window.	<p>A corresponding external volume was not found for the external path with the highest priority.</p> <p>Look for problems with the connection to the external system that failed during volume discovery. Fix any problems, and perform the operation again.</p>
External volume discovery was not completed because of failure.	Look for problems with the connection to the external system; also verify that the external volume is correctly configured in the external system. Fix any problems, and then perform the operation again.
After reconnecting an external volume or system, 10 minutes have passed but the status has not change from Checking .	<p>Click Refresh on the Device Manager - Storage Navigator main window. If the status remains Checking, perform the reconnect operation again.</p> <p>If the problem persists after about 10 minutes, contact Hitachi Data Systems customer support.</p>
Progress is not updated after disconnecting a storage system or an external volume.	<p>Click Refresh on the Device Manager - Storage Navigator main window.</p> <p>Note that the time required for write processing from cache to the external volume depends on volume capacity. More time is required for larger volumes. Processing speed is about 20 MB/s.</p>

Symptom	Possible causes and troubleshooting steps
	However, the processing speed also depends on the performance and status of the external system.
A message saying that intervention is required is issued to the mainframe host.	The device status is currently changing. Wait a few minutes, and then check the status again. When the transition of the device status has completed normally, the device can be used immediately. If the device is blocked as a result of the status transition, see the problem above, "The external volume is blocked".
A message saying that the device is blocked is issued to the mainframe host.	See the problem above, "The external volume is blocked"

Troubleshooting external path status

The following table shows path statuses in the **View External LUN Properties** window. Descriptions and corrective actions you can take are provided.

Also, see [Troubleshooting path errors for specific storage systems on page 6-6](#).

Status	Description	Corrective action
Unknown	The path status cannot be determined.	Contact Hitachi Data Systems customer support.
Blockade	The external port is blocked.	The port is blocked because of microcode replacement, package replacement, or other factor. Check the status of the local storage system. If you cannot restore the path, contact Hitachi Data Systems customer support.
External device setting changed	An external system setting has changed. For example, the path definition was deleted, or the external system itself was replaced by another device.	The port of the external system is recognized. See your device manufacturer's documentation to verify that the settings on the volumes in question have not changed.
LDEV size reduced	The external volume capacity was reduced.	Check the external volume capacity. Delete the external volume, and then remap to it.
Not ready	The reply of the external system was NOTREADY. Either the drive is spinning up or the system is being formatted.	The path cannot be used to access the external system. Check the status of the external system. If you cannot restore the path, contact Hitachi Data Systems customer support.

Status	Description	Corrective action
Illegal request	The reply of the external system was ILLEGALREQUEST. The command cannot be run on the external system. Data protection might be set on the external system.	The external system port is recognized. Check the external system settings and correct any problems. If you cannot restore the path, contact Hitachi Data Systems customer support.
Command aborted	The reply of the external system was ABORTEDCOMMAND. An error may have occurred on the external system side.	The external system port is recognized. Check external system settings and the physical connection to the external system (cables and switches) and correct any problems. If you cannot restore the path, contact Hitachi Data Systems customer support.
Busy	The external system is in the BUSY status.	The external system port is recognized. Check whether the external system configuration causes excessive load on the system. If the load is excessive, lower the load. If you cannot restore the path, contact Hitachi Data Systems customer support.
Response error	The external system is in blocked status caused by an abnormal reply (Response). You may not be able to access the system, or data protection may be set.	The external system port is recognized. Check the settings and status of the external system and fix any problems. If you cannot restore the path, contact Hitachi Data Systems customer support.
Initiator port	The port attribute of the external system has been changed to "initiator".	Set the port attribute of the external system to "target". If you cannot restore the path, contact Hitachi Data Systems customer support.
Destage Failed	The writing of data from cache memory to the external volume failed.	Reconnect the external volume or system. When status is Normal, disconnect the volume or system. You may need to try this multiple times. If the problem persists after the external volume or system has been disconnected and reconnected multiple times, contact Hitachi Data Systems customer support.
Unknown port	The port attribute of the external system is unknown.	The external system port is recognized. Check external system settings and the physical connection to the external system (cables and switches), and fix any problems. If you cannot restore the path, contact Hitachi Data Systems customer support.

Status	Description	Corrective action
Cannot detect port	<p>The external path has been removed or the external system port cannot be found. Possible causes are:</p> <ul style="list-style-type: none"> • The fiber cable is not properly connected. • The topology does not match between the external and target ports. • Because security is set on the port, the external system cannot be recognized from the local system. • If the external system is connected through switches, the switch setting may be incorrect. 	If you cannot restore the path after checking the possible causes, contact Hitachi Data Systems customer support.
Internal error	A program error occurred, or there is a logical contradiction.	Contact Hitachi Data Systems customer support.
Timeout	Processing was retried after an abnormal reply. However, processing stopped because of a timeout.	The external system port is recognized. Check external system settings and the physical connection to the external system (cables and switches). If you cannot restore the path, contact Hitachi Data Systems customer support.
Device check error	An external volume is mapped, but you cannot access the volume in the external system.	<p>Check the volume's status in the external system and take any necessary corrective action.</p> <p>Format the volume if it is not formatted.</p>
Medium error	The external volume has become inaccessible.	<p>Check the volume's status in the external system and take any necessary corrective action.</p> <p>Format the volume if it is not formatted.</p>

Troubleshooting path errors for specific storage systems

The following error types of error messages include storage-system-specific recovery information:

- External device setting changed
- Illegal request
- Cannot detect port

VSP G1000 Storage System

Path Status	Description and corrective actions
External device setting changed	<ul style="list-style-type: none"> • LU path settings can be changed by using LUN Manager. Either change the settings back to the values used when the volume was mapped, or use Universal Volume Manager software to Delete LU and then Add LU. • The access attribute of the volume might have been changed by Data Retention Utility. If the volume is protected by the access attribute, release the protection.
Illegal request or Response error	<ul style="list-style-type: none"> • If the volume is a pair volume, it may be protected because of the pair status. If this is the case, change the pair status or delete the pair. Make sure the volume is not set to a pair such as TrueCopy, Universal Replicator, ShadowImage, or global-active device. • The access attribute of the volume may have been changed by Data Retention Utility. If the volume is protected by the access attribute, release the protection.
Cannot detect port	<ul style="list-style-type: none"> • There is a problem with connection to the external storage system. The possible causes are: <ul style="list-style-type: none"> - Fiber cable connection. Make sure the fiber cable is connected correctly. - Fiber Channel port settings. The topology settings of the external port and the target port might not match. Use LUN Manager to make sure that the Fibre Channel ports are set properly. - Switch settings. If the external storage system is connected through switches, make sure that the switch settings are correct. • LUN security may have been enabled by using LUN Manager. If so, disable it in the Edit Port window.

Unified Storage VM, Virtual Storage Platform, and Universal Storage Platform V/VM

Path Status	Description and corrective actions
External device setting changed	<ul style="list-style-type: none"> • LU path settings can be changed by using LUN Manager. Either change the settings back to the values used when the volume was mapped, or use Universal Volume Manager software to Delete LU and then Add LU. • The access attribute of the volume might have been changed by Data Retention Utility. If the volume is protected by the access attribute, release the protection.
Illegal request or Response error	<ul style="list-style-type: none"> • If the volume is a pair volume, it may be protected because of the pair status. If this is the case, change the pair status or delete the pair. • The volume's access attribute may have been changed by Data Retention Utility. If the volume is protected by the access attribute, release the protection.
Cannot detect port	<ul style="list-style-type: none"> • There is a problem with connection to the external storage system. The possible causes are:

Path Status	Description and corrective actions
	<ul style="list-style-type: none"> - Fiber cable connection. Make sure the fiber cable is connected correctly. - Fiber Channel port settings. The topology settings of the external port and the target port might not match. Use LUN Manager to make sure that the Fibre Channel ports are set properly. - Switch settings. If the external storage system is connected through switches, make sure that the switch settings are correct. • LUN security may have been enabled by LUN Manager. If so, disable it in the Edit Port window.

Universal Storage Platform / TagmaStore NSC

Path Status	Description and corrective actions
External device setting changed	<ul style="list-style-type: none"> • LU path settings can be changed by using LUN Manager. Either change the settings back to the values used when the volume was mapped, or use Universal Volume Manager software to Delete LU and then Add LU. • The access attribute of the volume might have been changed by Data Retention Utility. If the volume is protected by the access attribute, release the protection.
Illegal request or Response error	<ul style="list-style-type: none"> • If the volume is a pair volume, it may be protected because of the pair status. If this is the case, change the pair status or delete the pair. Make sure the volume is not set to a pair such as Continuous Access Synchronous, Continuous Access Journal, Business Copy, or High Availability. • The volume's access attribute may have been changed by Data Retention. If the volume is protected by the access attribute, release the protection.
Cannot detect port	<ul style="list-style-type: none"> • There is a problem with connection to the external storage system. The possible causes are: <ul style="list-style-type: none"> - Fiber cable connection. Make sure the fiber cable is connected correctly. - Fiber Channel port settings. The topology settings of the external port and the target port might not match. Use LUN Manager to make sure that the Fibre Channel ports are set properly. - Switch settings. If the external storage system is connected through switches, make sure that the switch settings are correct. • LUN security may have been enabled by LUN Manager. If so, disable it in the Edit Port window.

Lightning 9900 V

Path Status	Description and corrective actions
External device setting changed	<ul style="list-style-type: none"> • LU path settings can be changed by using LUN Manager. Either change the settings back to the values used when the volume was mapped, or use Universal Volume Manager software to Delete LU and then Add LU.

Path Status	Description and corrective actions
	<ul style="list-style-type: none"> The access attribute of the volume might have been changed by Data Retention Utility. If the volume is protected by the access attribute, release the protection.
Illegal request or Response error	<ul style="list-style-type: none"> If the volume is a pair volume, it may be protected because of the pair status. If this is the case, change the pair status or delete the pair. Make sure the volume is not set to a pair such as Continuous Access Synchronous, Continuous Access Journal, Business Copy, or High Availability. The volume's access attribute may have been changed by Data Retention. If the volume is protected by the access attribute, release the protection.
Cannot detect port	<ul style="list-style-type: none"> There is a problem with connection to the external storage system. The possible causes are: <ul style="list-style-type: none"> Fiber cable connection. Make sure the fiber cable is connected correctly. Fiber Channel port settings. The topology settings of the external port and the target port might not match. Use LUN Manager to make sure that the Fibre Channel ports are set properly. Switch settings. If the external storage system is connected through switches, make sure that the switch settings are correct. LUN security may have been enabled by LUN Manager. If so, disable it in the Edit Port window.

Lightning 9900

Path Status	Description and corrective actions
External device setting changed	<ul style="list-style-type: none"> LU path settings can be changed by using LUN Manager. Either change the settings back to the values used when the volume was mapped, or use Universal Volume Manager software to Delete LU and then Add LU. The access attribute of the volume might have been changed by Data Retention Utility. If the volume is protected by the access attribute, release the protection.
Illegal request or Response error	<ul style="list-style-type: none"> If the volume is a pair volume, it may be protected because of the pair status. If this is the case, change the pair status or delete the pair. Make sure the volume is not set to a pair such as Continuous Access Synchronous, Continuous Access Journal, Business Copy, or High Availability. The volume's access attribute may have been changed by Data Retention. If the volume is protected by the access attribute, release the protection.
Cannot detect port	<ul style="list-style-type: none"> There is a problem with connection to the external storage system. The possible causes are: <ul style="list-style-type: none"> Fiber cable connection. Make sure the fiber cable is connected correctly. Fiber Channel port settings. The topology settings of the external port and the target port might not match. Use LUN Manager to make sure that the Fibre Channel ports are set properly.

Path Status	Description and corrective actions
	<ul style="list-style-type: none"> - Switch settings. If the external storage system is connected through switches, make sure that the switch settings are correct. • LUN security may have been enabled by LUN Manager. If so, disable it in the Edit Port window.

Thunder 9500V

Path Status	Description and corrective actions
External device setting changed	<ul style="list-style-type: none"> • LU path settings can be changed by using LUN Manager. Either change the settings back to the values used when the volume was mapped, or use Universal Volume Manager software to Delete LU and then Add LU. • The access attribute of the volume might have been changed by Data Retention Utility. If the volume is protected by the access attribute, release the protection.
Illegal request or Response error	<ul style="list-style-type: none"> • If the volume is a pair volume, it may be protected because of the pair status. If this is the case, change the pair status or delete the pair. Make sure the volume is not set to a pair such as Continuous Access Synchronous, Continuous Access Journal, Business Copy, or High Availability. • The volume's access attribute may have been changed by Data Retention. If the volume is protected by the access attribute, release the protection.
Cannot detect port	<ul style="list-style-type: none"> • There is a problem with connection to the external storage system. The possible causes are: <ul style="list-style-type: none"> - Fiber cable connection. Make sure the fiber cable is connected correctly. - Fiber Channel port settings. The topology settings of the external port and the target port might not match. Use LUN Manager to make sure that the Fibre Channel ports are set properly. - Switch settings. If the external storage system is connected through switches, make sure that the switch settings are correct. • The host group LUN security may have been enabled by LUN Management. If so, disable it in the Edit Port window.

HUS/AMS/WMS

Path Status	Description and corrective actions
External device setting changed	<ul style="list-style-type: none"> • LU path settings can be changed by using LUN Manager. Either change the settings back to the values used when the volume was mapped, or use Universal Volume Manager software to Delete LU and then Add LU. • The access attribute of the volume might have been changed by Data Retention Utility. If the volume is protected by the access attribute, release the protection.
Illegal request or	<ul style="list-style-type: none"> • If the volume is a pair volume, it may be protected because of the pair status. If this is the case, change the pair status or delete the

Path Status	Description and corrective actions
Response error	<p>pair. Make sure the volume is not set to a pair such as Continuous Access Synchronous, Continuous Access Journal, Business Copy, or High Availability.</p> <ul style="list-style-type: none"> The volume's access attribute may have been changed by Data Retention. If the volume is protected by the access attribute, release the protection.
Cannot detect port	<ul style="list-style-type: none"> There is a problem with connection to the external storage system. The possible causes are: <ul style="list-style-type: none"> Fiber cable connection. Make sure the fiber cable is connected correctly. Fiber Channel port settings. The topology settings of the external port and the target port might not match. Use LUN Manager to make sure that the Fibre Channel ports are set properly. Switch settings. If the external storage system is connected through switches, make sure that the switch settings are correct. The host group LUN security may have been enabled by LUN Manager. If so, disable it in the Edit Port window.

SVS200

Path Status	Description and corrective actions
External device setting changed	<ul style="list-style-type: none"> LU path settings can be changed by using LUN Manager. Either change the settings back to the values used when the volume was mapped, or use Universal Volume Manager software to Delete LU and then Add LU. The access attribute of the volume might have been changed by Data Retention Utility. If the volume is protected by the access attribute, release the protection.
Illegal request or Response error	<ul style="list-style-type: none"> If the volume is a pair volume, it may be protected because of the pair status. If this is the case, change the pair status or delete the pair. Make sure the volume is not set to a pair such as Continuous Access Synchronous, Continuous Access Journal, Business Copy, or High Availability. The volume's access attribute may have been changed by Data Retention. If the volume is protected by the access attribute, release the protection.
Cannot detect port	<ul style="list-style-type: none"> There is a problem with connection to the external storage system. The possible causes are: <ul style="list-style-type: none"> Fiber cable connection. Make sure the fiber cable is connected correctly. Fiber Channel port settings. The topology settings of the external port and the target port might not match. Use LUN Manager to make sure that the Fibre Channel ports are set properly. Switch settings. If the external storage system is connected through switches, make sure that the switch settings are correct. LUN security may have been enabled by LUN Management. If so, disable it in the Edit Port window.

Troubleshooting port and volume discovery problems

The following table shows corrective actions you can take for port and volume discovery problems.

Problem	Corrective action
The port on the local storage system and port on the external system are not connected.	Connect the External port of the local system and the external system port.
The cable for the switch is not connected correctly, or the switch's port is blocked.	Connect the cable to the correct port on the switch. Or change the port status to the normal status.
Zoning for the switch is not set appropriately.	Make sure the zoning configuration allows the External port of the local system to communicate with the external system port.
The external system is not connected to the External port on the local system.	Connect the external system to the External port of the local system. If necessary, change the local system port setting to "External".
External volume returned RESERVATION CONFLICT.	Release the reserved state of the external volume.
Port security is set on the external system.	Cancel the port security setting or change the security of the external system so that the local system can access the port of the external system.
No LU is configured on the external system port.	Configure an LU on the port.
External volume capacity is less than the supported capacity for Universal Volume Manager.	Perform one of the following: <ul style="list-style-type: none"> • Increase the external volume's capacity to be equal or larger than the supported capacity. • Use a security function or delete the LU setting from the external system port so that the local system cannot recognize a volume with insufficient capacity.
The external volume is configured as a management LU.	If a management LU, such as Universal Xport LU, is configured on the external system port, perform one of the following: <ul style="list-style-type: none"> • Make sure that at least one LU is used for data storage and has a smaller LUN than the management LU's LUN. Also make sure that the data storage LU is set to the port connected to the local system. • Delete the management LU from the port connected to the local system. • Use a security function and configure the access attribute of the management LU to prohibit read and write operations.
Remote command devices of the external system are cascaded.	Perform one of the following: <ul style="list-style-type: none"> • Change the configuration so that the remote command devices are not cascaded. • Use a security function or delete the LU setting from the port of the connected

Problem	Corrective action
	external system so that the local system cannot recognize the remote command devices.
External system information retrieved by port discovery is not found in the profile information.	Perform one of the following: <ul style="list-style-type: none"> • Connect an external system supported by Universal Volume Manager. • Contact Hitachi Data Systems customer support to ask if the external system is supported by Universal Volume Manager. If the system is supported, install the microcode version that supports the external system or install the profile information of the external system.
Login to the external system failed.	Perform one of the following: <ul style="list-style-type: none"> • Make sure that the port status of the external system is Normal. • Register the WWN to the external system to allow login from the local system.
The external volume is not in Normal status, or a failure or error occurred in retrieving information from the external system.	Make sure that the status of the external system or the external volume is Normal. If none of the actions suggested in the table provide volume discovery, remove the cable connection between the local and external storage systems, and then reconnect the storage systems. After 30 seconds, retry the operation.

Supported external storage systems

This chapter describes required configuration settings for many of the supported external storage systems.

- [External systems](#)
- [Hitachi Virtual Storage Platform G200, G400, G600](#)
- [HUS VM Storage System](#)
- [Virtual Storage Platform](#)
- [Virtual Storage Platform G1000](#)
- [Universal Storage Platform V/VM](#)
- [Universal Storage Platform/TagmaStore NSC](#)
- [Lightning 9900 V](#)
- [Lightning 9900](#)
- [Thunder 9500V](#)
- [HUS/AMS/WMS](#)
- [SVS200 storage system](#)
- [EVA storage system](#)
- [Sun StorEdge 6120/6320](#)

- [Sun StorageTek FlexLine 380](#)
- [Sun StorageTek 2540](#)
- [Sun StorageTek V2X2](#)
- [EMC CLARiiON CX series](#)
- [EMC VNX series](#)
- [EMC Symmetrix series](#)
- [IBM DS3000/DS4000/DS5000 series](#)
- [IBM V7000 series](#)
- [IBM SVC series](#)
- [IBM XIV series](#)
- [Fujitsu FibreCAT CX series](#)
- [Fujitsu DX60/80/90 S2 and Fujitsu DX400 S2](#)
- [SGI IS4600 series](#)
- [3Par T800, F400, V800, V400 series](#)
- [Storage system with a product name displayed as \(generic\)](#)

External systems

The storage systems in the following sections can be connected to VSP G1000 as external storage systems.



Note: Not all supported systems' information is provided here. If you do not find your storage system, refer to <http://www.hds.com/products/storage-systems/specifications/supported-external-storage.html> for a complete listing.

Hitachi Virtual Storage Platform G200, G400, G600

Use the following settings on the external system:

- The port must be set to the host group for the Windows hosts (host mode 0C: Windows, host mode 2C: Windows Extension).
- If the external Hitachi Virtual Storage Platform G200, G400, G600 storage system uses Data Retention Utility, set system option mode (SOM) 701 to ON on the local Hitachi Virtual Storage Platform G1000 system.

HUS VM Storage System

Use the following settings on the external system:

- The port must be set to the host group for the Windows hosts (host mode 0C: Windows, host mode 2C: Windows Extension).
- The port attribute must be set to **Target port** or **RCU target port**.
- If the external HUS VM Storage System uses Data Retention Utility, set System Option Mode (SOM) 701 to **ON** on the local VSP G1000 system.

Virtual Storage Platform

Use the following settings on the external system:

- The port must be set to the host group for the Windows hosts (host mode 0C: Windows, host mode 2C: Windows Extension).
- The port attribute must be set to **Target port** or **RCU target port**.
- If the external VSP Storage System uses Data Retention Utility, set System Option Mode (SOM) 701 to **ON** on the local VSP G1000 system.

Virtual Storage Platform G1000

Use the following settings on the external system:

- The port must be set to the host group for the Windows hosts (host mode 0C: Windows, host mode 2C: Windows Extension).
- The port attribute must be set to **Target port** or **RCU target port**.

- If the external VSP G1000 system uses Data Retention Utility, set System Option Mode 701 to **ON** on the local VSP G1000 system.

Universal Storage Platform V/VM

Use the following settings on the external system:

- The port must be set to the host group for the Windows hosts (host mode 0C: Windows, host mode 2C: Windows Extension).
- The port attribute must be set to **Target port** or **RCU target port**.
- If the external USP V/VM system uses Data Retention Utility, set SOM 701 to **ON** on the local VSP G1000 system.

Universal Storage Platform/TagmaStore NSC

Use the following settings on the external system:

- The port must be set to the host group for the Windows hosts (host mode 0C: Windows, host mode 2C: Windows Extension).
- The port attribute must be set to **Target port** or **RCU target port**.
- If the external USP system uses Data Retention Utility, set SOM 701 to **ON** on the local VSP G1000 system.

Host mode option for a volume larger than 2 TB

If a volume's capacity is more than 2 TB, host mode option No. 24 must be enabled before mapping it as an external volume. For instructions, see the *LUN Manager User's Guide* for the Universal Storage Platform / TagmaStore NSC storage system.

Lightning 9900 V

Use the following settings on the external system:

- The port must be set to the host group for the Windows hosts (host mode 0C: Windows, host mode 2C: Windows Extension).
- The port attribute must be set to **Target port** or **RCU target port**.

Lightning 9900

Use the following settings on the external system:

- The port's host mode must be set to PC Server (0C).
- The port attribute must be set to **Target port** or **RCU target port**.

Thunder 9500V

The following versions are recommended. If you use an earlier version, the SATA drive information may not display correctly.

- For Thunder 9530V, Thunder 9520V, Thunder 9570V: version 0658 or later.
- For Thunder 9580V, Thunder 9585V: version 1658 or later.

The following table shows the system parameters that must be specified for ports on the Thunder 9500V storage system.

Window Names	Parameters	Parameter Settings
System Startup Settings	Start Attribute	
	Single Mode	Use when the Thunder 9500V is in a one-controller configuration.
	Dual Active Mode	Use when the Thunder 9500V is in a two-controller configuration. Be sure to specify that Data Share Mode will be used.
	Hot Stand-By Mode	Do not specify this parameter.
Common 1	Delay Planned Shutdown	Optional
OPTION 1	SCSI Fibre Channel Common Options	Optional
OPTION 2	SCSI Fibre Channel Common Options	Optional
Data Striping	Operation if the processor failure occurs	Reset of occurred
Inquiry Setting	Command Queuing Mode	ON
	Vendor ID	HITACHI (default)
	Product ID	DF600F (default)
	ROM Microprogram Version	Optional
	RAM Microprogram Version	Optional
	WEB Title	Optional
Port Type	Reset/LIP Mode	
	Reset/LIP Mode (Signal)	Optional
	Reset/LIP Mode (Process)	Optional
	LIP Reset Mode	Optional
Controller Option	RS232C Error Information Outflow Mode	Optional
	Write and verify mode	ON
Host Connection Mode	Host Connection Mode 1	Standard Mode

Window Names	Parameters	Parameter Settings
	Host Connection Mode 2	HISUP Mode (do not specify any other parameter).

Identifying the 9500 V model using the serial number

You can identify the storage system model from the serial number displayed in the **Vendor / Model / Serial Number** column in the **External Storage System** tab.

The following table shows the relationship between the number in the **Serial Number** column and the storage system model.

Displayed Serial Number	Model
D600XXXX	9570V, 9520V
D60JXXXX	9530V
D60HXXXX	9580V, 9585V
Note: In serial numbers, "X" is an arbitrary number or character.	

Identifying the controller using the port WWN

You can identify the controller (controller 0 or controller 1) from the WWN of the port.

The following table describes the relationship between the port WWN and the controller.

Model	Controller	WWN of Port
9570V 9530V 9520V	Controller 0	XXXXXXXXXXXXXXXXX0 XXXXXXXXXXXXXXXXX1
	Controller 1	XXXXXXXXXXXXXXXXX2 XXXXXXXXXXXXXXXXX3
	Controller 0	XXXXXXXXXXXXXXXXX0 XXXXXXXXXXXXXXXXX1 XXXXXXXXXXXXXXXXX2 XXXXXXXXXXXXXXXXX3
9580V 9585V	Controller 1	XXXXXXXXXXXXXXXXX4 XXXXXXXXXXXXXXXXX5 XXXXXXXXXXXXXXXXX6 XXXXXXXXXXXXXXXXX7
	Note: In WWNs, "X" is an arbitrary number or character. The ports in the same physical storage system have the identical value.	

HUS/AMS/WMS

The table below shows the system parameters that must be specified for ports on HUS, AMS, and WMS storage systems when used with Universal Volume Manager. You can specify or omit any other parameters.

Also, ensure the following two settings *using Storage Navigator Modular or Storage Navigator Modular2*:

- Set the data transfer speed of the external port to a fixed value other than Auto.
- Set the data transfer speed of the target port of the HUS/AMS/WMS storage system to a fixed value consistent with the data transfer speed of the external port.

Window Names	Parameters	Parameter Settings
Boot Options	Start Attribute	
	Single Mode	Specify when HUS/AMS/WMS is in a one-controller configuration.
	Dual Active Mode	Specify when HUS/AMS/WMS is a two-controller configuration.
	Delay Planned Shutdown	Optional
	Drive blocking mode	Optional
	Vendor ID	HITACHI (default-do not change)
	Product ID	DF600F (default-do not change)
	ROM Microprogram Version	Optional
	RAM Microprogram Version	Optional
System Parameter	Option	Optional
	Operation if the processor failure occurs	Reset of occurred.
	WEB Title	Optional
	Write and verify mode	For AMS 1000, AMS 500, AMS 200 and WMS 100: ON For HUS 150, HUS 130, HUS 110, AMS 2500, AMS 2300, AMS 2100, and AMS 2010: OFF
Port Options	Port Option	Optional
Host Connection Mode	Host Connection Mode 1	Set AMS common setting to Standard Mode.
	Host Connection Mode 2	Do not specify any parameters for AMS additional settings. For AMS 1000, AMS 500, AMS 200 and WMS 100, do not specify HISUP OFF mode.

Identifying the HUS/AMS/WMS model using the serial number

When the external storage system is HUS, AMS, or WMS, you can identify the storage system model from the serial number displayed in the **Serial Number** column in the **Volume Operation** window.

The following table describes the relationship between the number in the Serial Number column and the storage system model.

Storage System	Displayed Serial Number	Model
HUS	95XXXXXX	HUS 150
	93XXXXXX	HUS 130
	91XXXXXX	HUS 110
AMS	87XXXXXX	AMS 2500
	85XXXXXX	AMS 2300
	83XXXXXX	AMS 2100, AMS 2010
	77XXXXXX	AMS 1000
	75XXXXXX	AMS 500
	73XXXXXX	AMS 200
WMS	71XXXXXX	WMS 100

In serial numbers, "X" is an arbitrary number or character.

When the model of HUS/AMS/WMS storage system is changed, the **Serial Number** is changed as well. If the HUS/AMS/WMS storage system is used as an external storage system, the mapped external volume may be blocked. To correct this problem, you can delete the mapping of the external volume and remap it to use the blocked external volume. See [Requirements for external storage system maintenance on page 5-31](#) for detailed information on remapping.

Identifying the controller using the port WWN (HUS/AMS/WMS)

When the external storage system is HUS, AMS, or WMS, you can identify the controller (controller 0 or controller 1) from the port WWN.

The following table describes the relationship between the port WWN and the controller.

Model	Controller	WWN of Port
AMS 200	Controller 0	XXXXXXXXXXXXXXXXX0
WMS 100	Controller 1	XXXXXXXXXXXXXXXXX1
AMS 2100	Controller 0	XXXXXXXXXXXXXXXXX0
AMS 2010		XXXXXXXXXXXXXXXXX1
AMS 500	Controller 1	XXXXXXXXXXXXXXXXX2

Model	Controller	WWN of Port
		XXXXXXXXXXXXXXXXX3
HUS 110 HUS 130 AMS 2300 AMS 1000	Controller 0	XXXXXXXXXXXXXXXXX0 XXXXXXXXXXXXXXXXX1 XXXXXXXXXXXXXXXXX2 XXXXXXXXXXXXXXXXX3
	Controller 1	XXXXXXXXXXXXXXXXX4 XXXXXXXXXXXXXXXXX5 XXXXXXXXXXXXXXXXX6 XXXXXXXXXXXXXXXXX7
HUS 150 AMS 2500	Controller 0	XXXXXXXXXXXXXXXXX0 XXXXXXXXXXXXXXXXX1 XXXXXXXXXXXXXXXXX2 XXXXXXXXXXXXXXXXX3 XXXXXXXXXXXXXXXXX4 XXXXXXXXXXXXXXXXX5 XXXXXXXXXXXXXXXXX6 XXXXXXXXXXXXXXXXX7
	Controller 1	XXXXXXXXXXXXXXXXX8 XXXXXXXXXXXXXXXXX9 XXXXXXXXXXXXXXXXXA XXXXXXXXXXXXXXXXXB XXXXXXXXXXXXXXXXXC XXXXXXXXXXXXXXXXXD XXXXXXXXXXXXXXXXXE XXXXXXXXXXXXXXXXXF
Note: In WWNs, "X" is an arbitrary number or character. The ports in a physical storage system have the identical value.		

When the model of HUS/AMS/WMS storage system is changed, the WWN of the port is changed as well. If the HUS/AMS/WMS storage system is used as an external storage system, the mapped external path may be blocked. To correct this problem, you can delete the mapping of the external path and remap it to use the blocked external path. See [Requirements for external storage system maintenance on page 5-31](#) for detailed information on remapping.

Identifying logical volumes using Characteristic 1

The Characteristic 1 value is the internal LUN number of the LUNS from the AMS/WMS.

Caution on using the power savings option

When an HUS 150, HUS 130, HUS 110, AMS 2500, AMS 2300, AMS 2100, or AMS 2010 storage system is connected as an external system with the Power Savings option is enabled, do not access external volumes from a host if the external volumes are spinning down. This prevents the external volume status from changing to **Blockade**.

If external volume status changes to **Blockade**, the volume is automatically restored in several hours. You can also manually restore the external volumes by reconnecting the external volume.

HUS and AMS 2000 series guidelines

- Avoid unnecessary load to the external storage system. Path mode between storage systems is Multi mode; therefore, when many external paths and mapping volumes are mapped, the load to the external system is high; some commands from host to VSP G1000 or from VSP G1000 to the external system may time out. To keep the proper load, the following is recommended.
 - Specify two external paths. Set the paths to the ports of each controller of the AMS 2000 series system.
 - Set the queue to 500 or fewer commands issued at the same time from a AMS 2000 series system. The formula to calculate the number of queue commands per system is as follows.
$$(\text{number of queues}) \times (\text{number of external paths}) \times (\text{number of concurrent external volume commands}) < 500$$

For more information about command queue settings, see [Editing external WWN settings on page 5-9](#).
- When using external volumes for replication, the copy operation needs to be distributed to two or more RAID groups.
There is an upper bound to the number of pairs that can be used for initial copy or resynchronization. Therefore, the copy operation may focus on a specific RAID group according to the order of the operation when it is performed to two or more external volumes.
If the copy operation focuses on a specific RAID group, then the AMS 2000 drive could bottleneck.

SVS200 storage system

Use the following settings on the external system:

- The port must be set to the host group for the Windows hosts (host mode 0C: Windows, host mode 2C: Windows Extension).
- The port attribute must be set to **Target port** or **RCU target port**.

EVA storage system

Use the following settings on the external system:

- The port must be configured as a target attached to a Windows host.
- EVA storage systems with microcode version 4.000 or later can be connected as an external system.
- On the local VSP G1000 storage system, set SOM 720 to **ON** for active path load-balancing support.

Set EVA system parameters in the following table. For parameters not shown, refer to the EVA system documentation for connection parameters.

Parameter		Parameter Setting
Add a Host	Host OS	Windows

The WWN of each VSP G1000 port connected to an EVA storage system must be registered to the EVA system. See EVA storage system documentation for details on registering WWNs

Identifying logical volumes using Characteristic 1

With an EVA external storage system, LUNs appear as Characteristic 1 in Device Manager - Storage Navigator windows.

If you search for the logical volumes by specifying the WWN for EVA Port A as illustrated in the following figure, logical volumes LUN 1 and LUN 2 are found for each of HostGroup-1 and HostGroup-2.

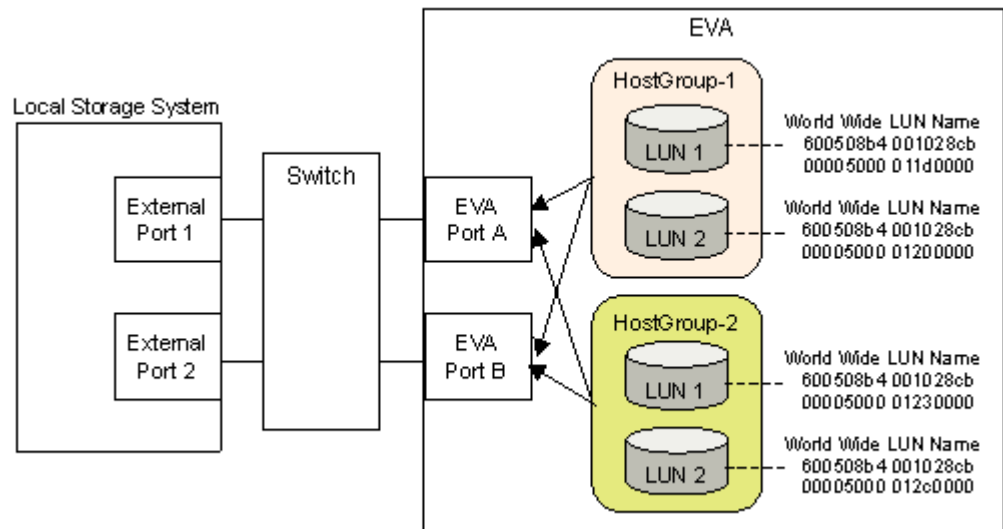

In this case, two different logical volumes with the same name (LUN 1 and LUN 2) are found that can be connected from EVA Port A. But you cannot determine which LUN 1 and LUN 2 belong to HostGroup-1 or HostGroup-2 only by Characteristic 1.

However, in Device Manager - Storage Navigator, you can identify the logical volumes referring to Characteristic 2. The first 32 characters of Characteristic 2 indicate the World Wide LUN Name. Identify the logical volume of the EVA storage system by this World Wide LUN Name.

Sun StorEdge 6120/6320

System Option Mode for connecting Sun StorEdge 6120/6320

When you connect Sun StorEdge 6120/6320 as an external storage system, you must set SOM 725 of the local storage system to ON. If SOM 725 is not set to ON, the external storage system might be blocked when performing maintenance tasks such as rebooting the controller of the external storage system before the firmware update.

For more information about using SOM 725, log on to the Hitachi Data Systems Support Portal: <https://Portal.HDS.com>.

System option parameters for connecting Sun StorEdge 6120/6320

The port must be configured as a target attached to a Windows host.

Set system parameters according to the following table. For connection parameters not shown, refer to the Sun StorEdge 6120/6320 system documentation.

On the local VSP G1000 storage system, set system option mode 725 to **ON** for support of Sun online maintenance operation.

Parameter	Parameter Setting
port host	SUN

Sun StorageTek FlexLine 380

System Option Mode for connecting Sun StorageTek FlexLine 380

When you connect Sun StorageTek FlexLine 380 as an external storage system, you must set SOM 725 of the local storage system to ON. If SOM 725 is not set to ON, the external storage system might be blocked when performing maintenance tasks such as rebooting the controller of the external storage system before the firmware update.

For more information about using SOM 725, log on to the Hitachi Data Systems Support Portal: <https://Portal.HDS.com>.

System option parameters for connecting Sun StorageTek FlexLine 380

The port must be configured as a target attached to a Windows host.

Set system parameters according to the following table. For connection parameters not shown, refer to the Sun StorageTek FlexLine 380 documentation.

Parameter	Parameter Setting
host type	Windows Non-clustered (DMP Support)

Sun StorageTek 2540

System Option Mode for connecting Sun StorageTek 2540

When you connect Sun StorageTek 2540 as an external storage system, you must set SOM 725 of the local storage system to ON. If SOM 725 is not set to ON, the external storage system might be blocked when performing maintenance tasks such as rebooting the controller of the external storage system before the firmware update.

For more information about using SOM 725, log on to the Hitachi Data Systems Support Portal: <https://Portal.HDS.com>.

System option parameters for connecting Sun StorageTek 2540

The port must be configured as a target attached to a Windows host.

Set system parameters according to the following table. For connection parameters not shown, refer to Sun StorageTek 2540 documentation.

Parameter	Parameter Setting
host type	Windows 2K non Clustered DMP

Sun StorageTek V2X2

The port must be configured as a target attached to a Windows host.

Important: Use only one external path when you mapping external volumes. Do not add alternate paths after you finish mapping external volumes.

EMC CLARiiON CX series

The port must be configured as a target attached to a Windows host.

System option mode for connecting EMC CLARiiON CX series

When you connect an EMC CLARiiON CX series as an external storage system, you must set SOM 725 of the local storage system to ON. If SOM 725 is not set to ON, the external storage system might be blocked when performing

maintenance tasks such as rebooting the controller of the external storage system before the firmware update.

For more information about using SOM 725, log on to the Hitachi Data Systems Support Portal: <https://Portal.HDS.com>.

System parameters for connecting EMC CLARiiON CX series

When you connect an EMC CLARiiON CX series as an external storage system, set the system parameters according to the following table.

Parameter	Setting
Initiator Type	CLARiiON Open
Failover Mode	2
ArrayCommPath	Disabled

For system parameters not shown in the table, see the EMC CLARiiON CX series documentation.



Note: Volumes created with Individual Disk Units (JBOD disks) of EMC CLARiiON CX series are not supported. Make sure to define the LU number for each port in the EMC CLARiiON CX side.

EMC VNX series

System option mode for connecting EMC VNX series

When you connect an EMC VNX series as an external storage system, you must set SOM 725 of the local storage system to ON. If SOM 725 is not set to ON, the external storage system might be blocked when performing maintenance tasks such as rebooting the controller of the external storage system before the firmware update.

For more information about using SOM 725, log on to the Hitachi Data Systems Support Portal: <https://Portal.HDS.com>.

System parameters for connecting EMC VNX series

When you connect an EMC VNX series as an external storage system, set the system parameters of the EMC VNX series according to the following table:

Parameter	Setting
Initiator Type	CLARiiON Open
Failover Mode	2
ArrayCommPath	Disable

For system parameters not shown in the table, see the EMC VNX series documentation.



Note: Volumes created with Individual Disk Units (JBOD disks) of EMC VNX series are not supported. Make sure to define the LU number for each port in the EMC VNX side.

EMC Symmetrix series

The port must be configured as a target attached to a Windows host.

Set system parameters according to the following table. For connection parameters not shown, refer to EMC Symmetrix series documentation

Parameter	Parameter Setting
SC3 flag	Enable
SPC2 flag	Disable

On the local VSP G1000 system, system option mode 745 needs to be **ON**.

IBM DS3000/DS4000/DS5000 series

The port must be configured as a target attached to a Windows host.

Set system parameters according to the following table. For connection parameters not shown, refer to IBM DS3000/DS4000/DS5000 series documentation.

Parameter	Parameter Setting
host type	When alternate paths are connected to different clusters on the DS3000/DS4000/DS5000 series side: Linux

IBM V7000 series

Set system parameters according to the following table. For connection parameters not shown, refer to the IBM V7000 series documentation.

Table A-1 System parameters for connecting IBM V7000 series

Parameter	Parameter setting
host type	generic

The model name of the IBM V7000 series is displayed as "SVC" on the Device Manager - Storage Navigator window.

IBM SVC series

The port must be configured as a target attached to a Windows host.

Set system parameters according to the following table. For connection parameters not shown, refer to IBM SVC series documentation.

Parameter	Parameter Setting
host type	generic

IBM XIV series

The port must be configured as a target attached to a Windows host.

Device serial number differs between IBM XIV series and VSP G1000, as shown in the following table.

Display in VSP G1000		Display in IBM XIV	
Item	Type	Item	Type
First 2 digits of Serial Number	Decimal value	First 2 digits of (System) Serial number	Decimal value
Last 5 digits of Serial Number	Hexadecimal value	Last 5 digits of (System) Serial number	Decimal value
Characteristic 1	Hexadecimal value	Device serial number	Decimal value

Fujitsu FibreCAT CX series

The port must be configured as a target attached to a Windows host.

Set system parameters according to the following table. For connection parameters not shown, refer to Fujitsu FibreCAT CX series documentation.

Parameter	Parameter Setting
Initiator Type	CLARiiON Open
Failover Mode	2

Volumes created with the RAID0 level or Individual Disk Units (JBOD disks) of Fujitsu FibreCAT CX series are not supported.

System option mode for connecting Fujitsu FibreCAT CX series

When you connect the Fujitsu FibreCAT CX series as an external storage system, you must set SOM 725 of the local storage system to ON. If SOM 725 is not set to ON, the external storage system might be blocked when a

maintenance task such as rebooting the controller of the external storage system is performed before the firmware update.

For more information about using SOM 725, log on to the Hitachi Data Systems Support Portal: <https://Portal.HDS.com>.

Fujitsu DX60/80/90 S2 and Fujitsu DX400 S2

The port must be configured as a target attached to a Windows host.

Set system parameters according to the following table. For connection parameters not shown, refer to Fujitsu DX60/80/90 S2 or Fujitsu DX 400 S2 documentation.

Parameter	Parameter Setting
Inquiry VPD ID Type in Setup Host Response screen	Type1 + Type3
Load Balance Response in Setup Host Response screen	Busy

SGI IS4600 series

The port must be configured as a target attached to a Windows host.

Set system parameters according to the following table. For connection parameters not shown, refer to SGI IS4600 series documentation.

Parameter	Parameter Setting
host type	When alternate paths are connected to different clusters on the SGI IS4600 series side: Linux

3Par T800, F400, V800, V400 series

The port must be configured as a target attached to a windows host.

Set system parameters according to the following tables. For connection parameters not shown, refer to 3Par T800, F400, V800 or V400 series documentation.

For 3Par T800 and F400 series

Parameter	Parameter Setting
host mode	generic-legacy (or generic)

For 3Par V800 and V400 series

Parameter	Parameter Setting
host mode	generic-legacy

The volumes in which "Dynamic optimization" or "Adaptive optimization" is applied must not be used as the external volume of VSP G1000; otherwise the performance of the external volume may possibly be degraded and the operation cannot be guaranteed.

Storage system with a product name displayed as (generic)

The generic Universal Volume Manager profile (available with 70-04-x) provides support for connecting external storage systems that are attached using Fibre Channel, without testing them individually. It will automatically support storage systems that conform to a subset of the standard SCSI Primary Commands. (If you need further information, contact Hitachi Data Systems customer support). An HDS representative can perform a step-wise process to install and connect external storage. These steps (defined below) follow a standard process to ensure that no obvious problems exist in the virtualization. Updating a VSP G1000 to the minimum firmware level 70-05-0x automatically installs the generic UVM profile and makes it available.

Support conditions when product name displays as (generic)

When an external storage system is connected to a VSP G1000 and is supported with the generic UVM profile, the following support conditions exist.

- **Vendor name** that corresponds to the external storage system is displayed.
- **Product name** is displayed as (generic).



Note: If multiple generic storage systems of the same vendor are connected, they are displayed as a single storage system. As a result, if **Disconnect External Storage Systems** or **Reconnect External Storage Systems** is run for generic storage systems, all the generic storage system volumes are disconnected or reconnected. For disconnecting or reconnecting a particular generic storage system volume, the best practice is to run the command in the external volume unit rather than the external storage system unit.

-
- **Serial number** is not displayed.
 - **Characteristic 1 (device information).** LUN assigned to the path with the highest priority is displayed.
 - **Path Mode and Load Balance Mode.** Load Balance Mode is set to **Disable** by default. Three Path Mode settings are available:
 - a. **Normal Round-robin** (For Multi Path)
 - b. **Extended Round-robin** (For Multi Path)

c. **Disable** (For Single Path and ALUA)

By default, Load Balance Mode is set to **Disable** for the generic UVM profile. As a result, UVM uses Single Mode (Active/Passive). If the attached external storage supports Multi pathing (Active/Active), the Load Balance Mode setting must be changed to **Extended Round-robin** or **Normal Round-robin**.

The Load Balance Mode can be changed in the Add External Volumes window of Device Manager - Storage Navigator.

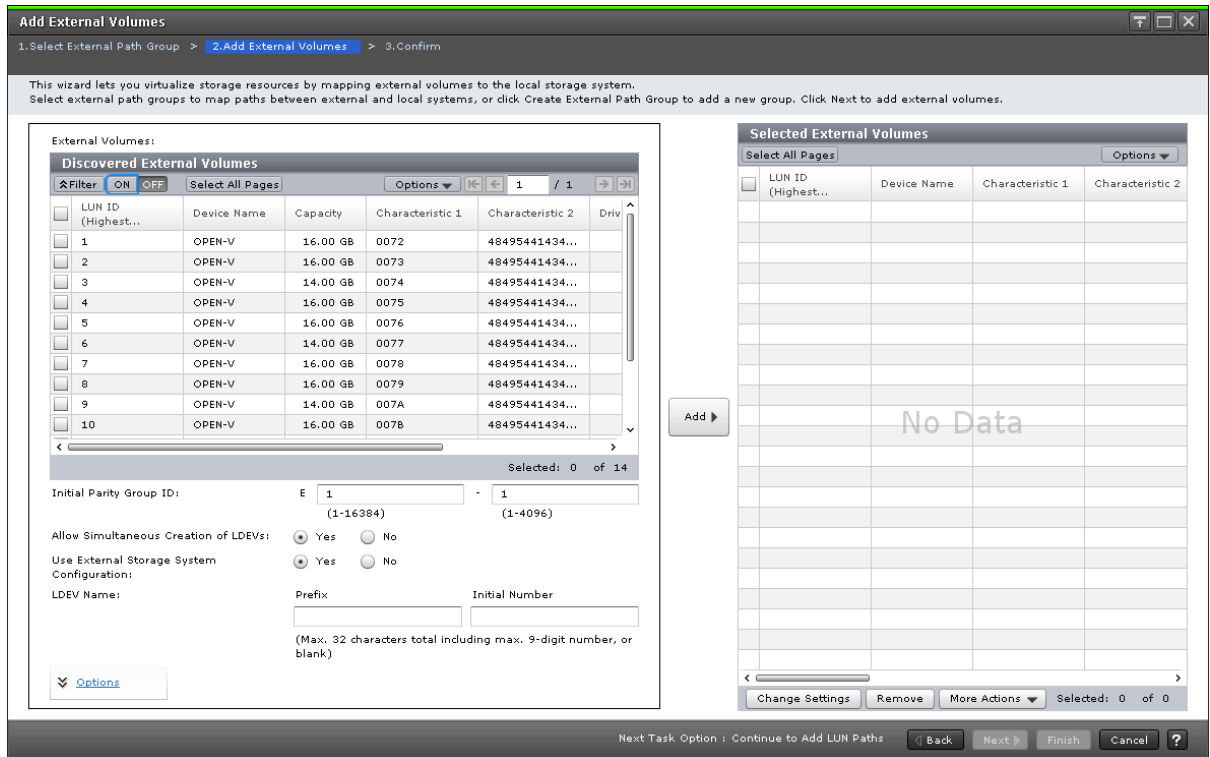

Note: If you need a profile that models your specific storage system, contact Hitachi Data Systems customer support. HDS will gather the required information and may provide the requested profile in a microcode update. Upgrading to the new microcode will allow the Universal Volume Manager to display the vendor name, product name, serial number, and path mode of the external volumes.

Virtualization support requirements

- The external storage system conforms to SCSI Primary commands (SPC-3).
- Inquiry page 0x83 contains device identifier 2h (EUI-64-based) or 3h (NAA).
- The alternate path mode is not Active/Standby. (Active/Standby is a Single Mode much like Active/Passive, but it does not failover automatically.)
- A profile specific to the storage system does not exist.

- A special device driver or path manager is not required to control the external storage system.
- All other restrictions referenced in this guide apply to virtualization specifications.

Suggested virtualization procedure

Procedure:

1. Set up VSP G1000 External ports.
2. Connect the external storage FC ports to the VSP G1000 External ports.
3. Virtualize at least four LUNs from the external storage.
 - If virtualization fails, contact Hitachi Data Systems customer support.
4. Connect two FC ports of the VSP G1000 to two HBAs of the server.
5. Provision the ELUNs mapped to the LUNs (step 3) on the ES to the UVM FC ports.
6. Run an I/O generator to the virtualized LUNs. IOMETER or VDBENCH can be used.
 - a. Delete the external path of the highest priority during the I/O.
 - b. Add the external path as the highest priority during the I/O.
7. Stop the I/O.



Note: The collection of information is optional but recommended. HDS asks that if new branded storage is attached that the local HDS representative collect the required data to send to Hitachi. After reviewing the data, Hitachi will add the External Storage Model to a listing of supported models on the HDS website. Hitachi may also provide a profile that models your specific storage system. You have the option of continuing to use the external storage system or waiting for your customized profile. If the required data is not provided, HDS support may be limited until the data is sent to Hitachi.

Remote command devices

This chapter describes information for mapping to command devices in external storage systems.

- [Overview of remote command devices](#)
- [Storage systems supported for remote command devices](#)
- [Requirements](#)
- [Restrictions and other information](#)
- [Mapping a command device](#)

Overview of remote command devices

You can map to a volume used as a command device in an external system. From the local system, the mapped command device volume becomes a remote command device.

A Universal Volume Manager license is not required for a remote command device mapping operation.

From an OPEN-systems host connected to the local system, you can issue ShadowImage, TrueCopy, or other commands from Command Control Interface (CCI) to the remote command device. The commands are relayed from the remote command device to the external system where they are executed for pairs such as those for ShadowImage and TrueCopy. This process is outlined in the following figure.

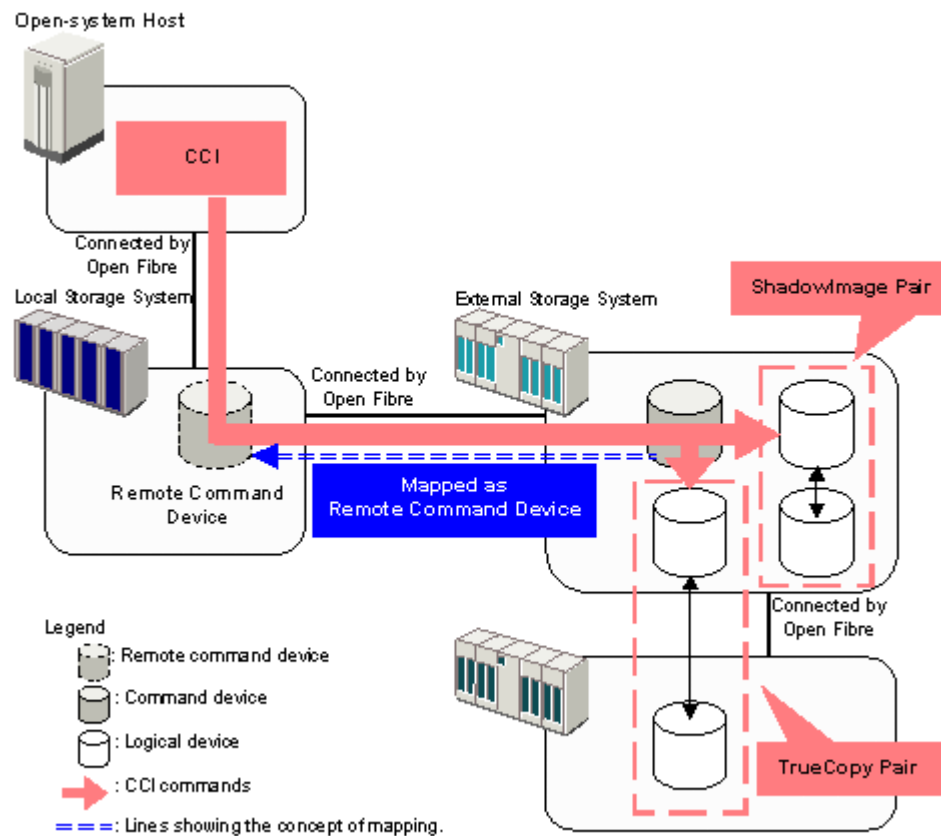

Figure B-1 Outline of remote command device

Storage systems supported for remote command devices

You can map a command device in one of the following external storage system as a remote command device in VSP G1000:

- VSP G1000
- Unified Storage VM

- Virtual Storage Platform
- Universal Storage Platform V
- Universal Storage Platform VM
- SANRISE Universal Storage Platform
- SANRISE Network Storage Controller
- Unified Storage
- Adaptable Modular Storage
- Workgroup Modular Storage
- SANRISE9900V series
- SANRISE9500V series
- TagmaStore Universal Storage Platform
- TagmaStore Network Storage Controller
- Lightning 9900V series
- Thunder 9500V series
- Virtual Storage Platform VX7
- VP9500
- H24000
- H20000
- SANRISE H12000
- SANRISE H10000
- SANRISE H1024/H128
- HP XP7 Storage
- P9500
- XP24000
- XP20000
- XP12000
- XP10000
- XP1024/XP128

Requirements

The following table shows requirements for mapping a command device as a remote command device.

Table B-1 Restrictions on remote command device

Item	Requirement
Emulation type	OPEN-V
Number of LDEVs in an external volume	1
Cache mode	Disable

Item	Requirement
Minimum capacity	96,000 Blocks (about 47 MB)
Maximum capacity	4TB
Maximum number of the available CCI instances per remote command device	16*
* Maximum number of available CCI instances may be less than 16, dependent upon the number of paths between a local storage system and an external storage system.	

Restrictions and other information

Before mapping a command device as a remote command device, note the following information.

- The remote command device cannot be identified by port discovery or volume discovery process that takes place during the mapping operation.
- When an external storage system (A) has a remote command device (B) (that is, when a command device in another external storage system (C) is mapped to this external storage system (A)), make sure that the remote command device (B) does not have the smallest LUN on the port in the external storage system (A).
- You cannot execute I/O to the remote command device.
- You cannot set command device disable on the remote command device.
- You cannot set command device security on the remote command device.
- Do not set the command device security on the external storage system side for the command device that is mapped as a remote command device.
- You cannot create CVs using the VLL function in the remote command device.
- Cache Residency Manager is not available on the remote command device.
- Command device information reported to the local host by the remote command device includes the following:
 - Serial number
 - Vendor
 - Device name. The name displayed for many individual storage system is listed in [Supported external systems path mode for external volumes on page 2-16](#).
- Errors can occur when operations are performed on the remote command device, even though the status of the remote command device is normal. In this case, check the status of the command device on the external storage system where the error actually exists.

Mapping a command device

To map a command device, select a command device that can be mapped and follow the procedure in [Mapping an external volume on page 4-5](#).

When mapped, the remote command device appears in the Device Manager - Storage Navigator **Mapped Volumes** window, **Device Name** column as follows:

Storage system	Displayed information in Device Name column
VSP G1000 Unified Storage VM Virtual Storage Platform Universal Storage Platform V Universal Storage Platform VM SANRISE Universal Storage Platform SANRISE Network Storage Controller SANRISE9900V series TagmaStore Universal Storage Platform TagmaStore Network Storage Controller Lightning 9900V series Virtual Storage Platform VX7 VP9500 H24000 H20000 SANRISE H12000 SANRISE H1024/H128 HP XP7 Storage XP24000 P9500 XP24000 XP20000 XP12000 XP10000 XP1024/XP128	Format: "Emulation Type" + "-CM" Example: OPEN V-CM
Unified Storage Adaptable Modular Storage Workgroup Modular Storage SANRISE9500V series Thunder 9500V series	DF600F-CM



Command Control Interface command reference

This chapter lists Command Control Interface (CCI) commands that correspond to the Actions you select in Device Manager - Storage Navigator.

- [Device Manager - Storage Navigator Action names and CCI commands](#)

Device Manager - Storage Navigator Action names and CCI commands

The following table compares Actions you take in Device Manager - Storage Navigator and corresponding CCI commands.

SN location	SN Action name	CCI command
External Storage	Add External Volumes	raidcom add external_grp
	Delete External Volumes	raidcom delete external_grp
	Disconnect External Storage Systems	raidcom disconnect external_grp
	Reconnect External Storage Systems	raidcom check_ext_storage external_grp
	Edit External Volumes	raidcom modify external_grp
	Assign MP Blade	raidcom modify external_grp
	Disconnect External Volumes	raidcom disconnect external_grp
	Reconnect External Volumes	raidcom check_ext_storage external_grp
	Disconnect External Paths	raidcom disconnect path
	Reconnect External Paths	raidcom check_ext_storage path
	Edit External Path Configuration	raidcom add path raidcom delete path



Universal Volume Manager GUI reference

This appendix describes Device Manager - Storage Navigator windows, dialog boxes, and fields related to Universal Volume Manager.

- [External Storage window](#)
- [Selected external storage system window](#)
- [Selected external path group window](#)
- [Add External Volumes wizard](#)
- [Edit Policies window](#)
- [Edit External Volumes wizard](#)
- [Edit External Path Configuration wizard](#)
- [Edit External WWNs wizard](#)
- [Delete External Volumes wizard](#)
- [Disconnect External Paths wizard](#)
- [Reconnect External Paths wizard](#)
- [Discover External Target Ports window](#)
- [Create External Path Group window](#)

- [Change Settings window](#)
- [View External LUN Properties window](#)
- [Reconnect External Storage Systems window](#)
- [Reconnect External Volumes window](#)
- [Disconnect External Storage Systems window](#)
- [Disconnect External Volumes window](#)
- [Assign MP Blade wizard](#)
- [External LDEV Properties window](#)
- [Discovery Result Detail window](#)

External Storage window

Use this window to view external storage systems.

You can perform these operations from the window:

- [Mapping an external volume on page 4-5](#)
- [Editing mapping policies for external volumes on page 5-4](#)
- [Disconnecting an external path on page 5-13](#)
- [Reconnecting an external path on page 5-14](#)

Information areas in this window:

- [Summary on page D-3](#)
- [External Storage Systems tab on page D-3](#)
- [External Paths tab on page D-5](#)

Summary

Displays summary information for external storage.

Item	Description
Number of External Storage Systems	Number of external storage systems in which mapped external volumes reside.
Number of External Paths	Number of external paths.
Number of External Volumes	Number of mapped external volumes.
External Volume Capacity	Total capacity of mapped external volumes.

External Storage Systems tab

Displays the external storage systems in which mapped external volumes reside.

Item	Description
	<ul style="list-style-type: none"> • Cache Destage: Writing of data from cache memory to the volume is in progress. • Warning: There are mapping paths whose status is not normal. You can check their status in the View External LUN Properties window. • Blockade: The mapping path is blocked. • Destage Failed: The writing of data from cache memory to the volume failed.
Number of External Path Groups	Number of external path groups in the external system.
Add External Volumes	When clicked, launches the Add External Volumes window.
Disconnect External Storage Systems	When clicked, launches the Disconnect External Storage Systems window.
Reconnect External Storage Systems	When clicked, launches the Reconnect External Storage Systems window.
Edit Policies*	When clicked, launches the Edit Policies window.
Export*	When clicked, allows you to save table information to a file.
* Appears when you click More Actions .	

External Paths tab

Displays the paths connecting mapped external volumes in the external system to VSP G1000.

Item	Description
	<ul style="list-style-type: none"> • Unknown: The status of the external path is not known. • Warning: There are external paths whose status is not normal. You can check their status in the View External LUN Properties window. • Blockade: The external path is blocked.
QDepth	Number of Read/Write commands that can be queued to the external volume. 8 is set by default. When Load Balance Mode is Extended Round-robin and the I/Os issued to the external volume are sequential, the number of Read/Write commands that can be queued at one time is the total of the QDepth values of all the external paths.
I/O Timeout (sec.)	Number of seconds that should pass before I/O to the external volume times out. 15 seconds is the default.
Path Blockade Watch(sec.)	Time that will elapse from the time that a path goes down to the time when the external volume is blocked. 10 seconds is the default.
Disconnect External Paths	When clicked, launches the Disconnect External Paths window.
Reconnect External Paths	When clicked, launches the Reconnect External Paths window.
Edit External WWNs	When clicked, launches the Edit External WWNs window.
Edit Policies*	When clicked, launches the Edit Policies window.
Export*	When clicked, allows you to save table information to a file.
* Appears when you click More Actions .	

Selected external storage system window

Use this window to view information about the selected external storage system.

You can perform these operations from the window:

- [Mapping an external volume on page 4-5](#)
- [Adding an external path to an existing path group on page 5-11](#)
- [Changing external path priority on page 5-12](#)
- [Removing, replacing an external path on page 5-17](#)
- [Editing external volume policies \(settings\) on page 5-2](#)
- Export table information to a file.

Information areas in this window:

- [Summary on page D-8](#)
- [External Path Groups tab on page D-9](#)

Item	Description
	<ul style="list-style-type: none"> • Cache Destage: Writing of data from cache memory to the volume is in progress. • Warning: There are mapping paths whose status is not normal. You can check their status in the View External LUN Properties window. • Blockade: The mapping path is blocked. • Destage Failed: The writing of data from cache memory to the volume failed.
Vendor / Model / Serial Number	Identifying information for the external system.
Number of External Path Groups	Number of external path groups in the external system.
Number of External Volumes	Number of mapped external volumes.
External Volume Capacity	Total capacity of mapped external volumes.

External Path Groups tab

Displays the external path groups in which external paths are grouped.

Item	Description
External Path Group ID	Name of the external path group. When the link is clicked, the list of the group's external paths displays.
Status	Status of external path groups. <ul style="list-style-type: none"> • Normal: There are no problems, the path group is usable. • Disconnect: The path group has been intentionally disconnected. • Checking: The system is checking the mapping path status. • Unknown: The status of the mapping path is not known. • Cache Destage: The writing of data from cache memory to the external volume is in progress. • Warning: There are mapping paths whose status is not normal. You can check their status in the View External LUN Properties window. • Blockade: The mapping path is blocked. • Destage Failed: The writing of data from cache memory to the volume is failed.
Top Path	Highest priority external path.
Port ID	Displays the external port of the local storage system.
External WWN	Displays the WWN of the external storage system. The external WWN shows the target port.

Item	Description
Number of External Paths	Number of external paths in the path group.
Number of External Volumes	Number of external volumes using the external path group.
Add External Volumes	When clicked, launches the Add External Volumes window.
Edit External Path Configuration	When clicked, launches the Edit External Path Configuration window.
Edit Policies	When clicked, launches the Edit Policies window.
Export	When clicked, allows you to save table information to a file.

Selected external path group window

Use this window to view the mapped external volumes using the external path, and view the external paths in the path group.

You can perform these operations from the window.

- [Mapping an external volume on page 4-5](#)
- Edit Cache Mode and Inflow Control settings for individual mapped volumes (see [Editing mapping policies for external volumes on page 5-4](#))
- View path status and external LUN information (see the Status description in the [External Storage Systems tab on page D-3](#) section.)
- [Deleting an external volume mapping on page 5-29](#)
- [Disconnecting a single mapped volume on page 5-22](#)
- [Reconnecting a single mapped volume on page 5-26](#)
- [Changing MP blade for external volume on page 5-5](#)
- [Editing external volume policies \(settings\) on page 5-2](#)
- Export table information to a file (see the Export button description in [External Storage Systems tab on page D-3](#) section.)

Information areas in this window:

- [Summary on page D-10](#)
- [Mapped Volumes tab on page D-11](#)
- [External Paths tab on page D-15](#)

Summary

Displays summary information about the selected external path group.

Item	Description
Status	Status of path groups.

Item	Description
	<ul style="list-style-type: none"> • Normal: There are no problems, the path group is usable. • Disconnect: The path group has been intentionally disconnected. • Checking: The system is checking the mapping path status. • Unknown: The status of the mapping path is not known. • Cache Destage: The writing of data from cache memory to the external volume is in progress. • Warning: There are mapping paths whose status is not normal. You can check their status in the View External LUN Properties window. • Blockade: The mapping path is blocked. • Destage Failed: The writing of data from cache memory to the volume is failed.
Vendor / Model / Serial Number	Identifying information for the external system.
Number of External Paths	Number of external paths in the external path group.
Number of External Volumes	Number of mapped external volumes using the external path group.
External Volume Capacity	Total capacity of mapped external volumes using the path group.

Mapped Volumes tab

Displays the external volumes mapped to the VSP G1000 using the selected path group.

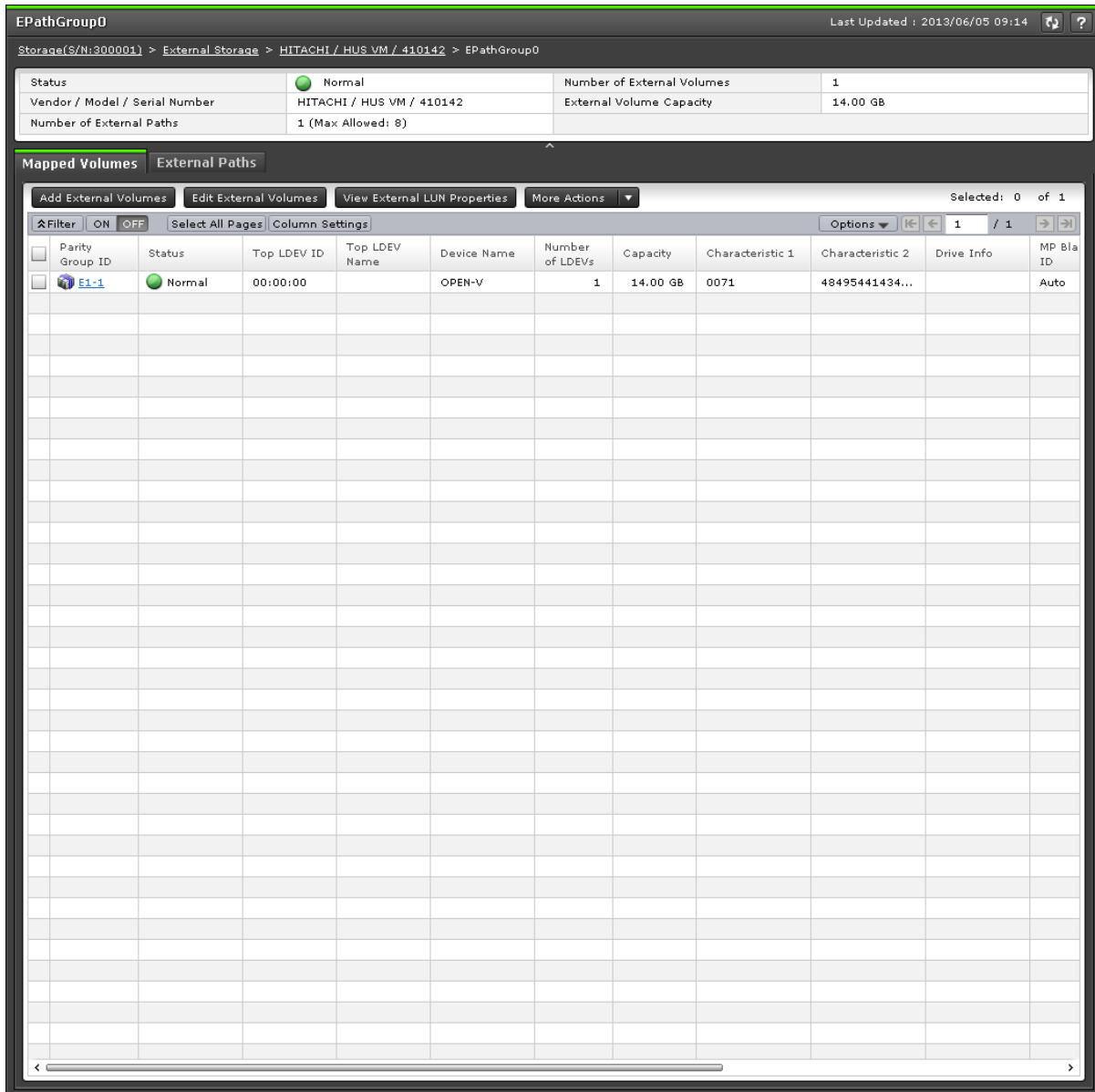

Item	Description
Parity Group ID	<p>Displays parity group numbers for the mapped external volumes. When the link is clicked, a list of LDEVs in the mapped volume and parity group displays.</p> <p>When the link is clicked, a list of LDEVs in the mapped volume and parity group displays.</p>
Status	<p>Status of the external volume</p> <ul style="list-style-type: none"> • Normal: There are no problems, the volume is usable. • Disconnect: The external system or one of its mapped volumes has been intentionally disconnected. • Checking: The system is checking the mapping path status • Unknown: The status of the mapping path is not known.

Item	Description
	<ul style="list-style-type: none"> • Cache Destage: Writing of data from cache memory to the volume is in progress. • Warning: There are mapping paths whose status is not normal. You can check their status in the View External LUN Properties window. • Blockade: The mapping path is blocked. • Destage Failed: The writing of data from cache memory to the volume failed.
Top LDEV ID	External volume's top LDEV ID.
Top LDEV Name	External volume's top LDEV name.
Device Name	Product ID of Standard Inquiry. This is the name defined by the standard body that controls SCSI. This name varies according to the storage system vendor. For example, for Hitachi enterprise storage, this field displays the emulation type.
Number of LDEVs	Number of LDEVs created in the external volume.
Capacity	Capacity of the external volume.
Characteristic 1	<p>Identification number of the external volume.</p> <p>The value is used by UVM to identify the LUN across multiple paths. The value is provided by the external system and may reflect internal numbering.</p>
Characteristic 2	Identification number of the external volume.
Drive Info	<p>Information about the external volume's drive type.</p> <p>SATA displays when the external volume is a SATA drive of following storage systems.</p> <ul style="list-style-type: none"> • Virtual Storage Platform • Universal Storage Platform V/VM • HUS/AMS/WMS • SMS • Thunder 9500V <p>SSD displays when the external volume is the SSD of following storage systems.</p> <ul style="list-style-type: none"> • Virtual Storage Platform G1000 • HUS VM Storage Platform • Virtual Storage Platform • Universal Storage Platform V/VM
MP Blade ID	MP blade IDs allocated to the external volume.
Path Mode	<p>Path mode for the external volume's external path.</p> <ul style="list-style-type: none"> • Single: Ordinarily, only one external path is used even if alternate paths are set. Alternate paths are available in case of failure. • Multi: Multiple paths are used at the same time. • ALUA: Like Multi, all paths are used; however, they are not used when connected to ports in Passive status.

Item	Description
	See External paths on page 2-14 for more information.
Path Mode on Profile ¹	<p>Displays the path mode on the profile information of the external storage system.</p> <ul style="list-style-type: none"> • Single: Ordinarily, only one external path is used even if alternate paths are set. • Multi: When alternate paths are set, external paths from several ports are used simultaneously with load balancing.
ALUA Settable ¹	<p>Displays whether ALUA can be set as the Path Mode in the external storage system.</p> <ul style="list-style-type: none"> • Enable: Enables ALUA Mode. • Disable: Disables ALUA Mode.
ALUA Permitted ¹	<p>Displays whether ALUA can be set as the Path Mode in the local storage system.</p> <ul style="list-style-type: none"> • Enable: ALUA Mode is used. • Disable: ALUA Mode is not used.
Load Balance Mode	<p>Displays I/O load balance system for external storage system.</p> <ul style="list-style-type: none"> • Normal Round-robin: Performs load balance in round-robin system. • Extended Round-robin: Load balance system is automatically switched for sequential I/O and random I/O. • Disable: Performs I/O operation with a single path, without load balance.
Cache Mode	<p>Write data from the host to the external system is propagated synchronously (Disable) or asynchronously (Enable).</p> <p>When nondisruptive migration is specified as the Attribute, the cache modes are displayed.</p> <ul style="list-style-type: none"> • Through: Transfers write and read requests from the host to the external storage system. The local system's cache is not used. • Write Sync: Reflects write data from the host to the external storage system synchronously. If read or write is performed while data is being written to the external storage system, the read or write operation waits until the ongoing write operation is completed. <p>While cache mode operations are in progress, status is reported for cache mode changes.</p> <ul style="list-style-type: none"> • (Changing): Transition to the displayed cache mode is in progress. • (Error): Transition to the displayed cache mode has failed and maintenance work is required.
Inflow Control	<p>Write operation to cache memory is limited (Enable) or continued (Disable) when the write operation to the external volume cannot be performed.</p>

Item	Description
Attribute	Displays the attribute of the attribute parity group. <ul style="list-style-type: none"> • nondisruptive migration: Parity group with the nondisruptive migration attribute • A blank displays if no attribute is set.
Add External Volumes	Displays the Add External Volumes window.
Edit External Volumes	Displays the Edit External Volumes window.
View External LUN Properties	View external system LUN information for the external volume, as well as external and mapping path information in the Displays the View External LUN Properties window.
Delete External Volumes ²	When clicked, launches the Delete External Volumes window.
Disconnect External Volumes ²	When clicked, launches the Disconnect External Volumes window.
Reconnect External Volumes ²	When clicked, launches the Reconnect External Volumes window.
Assign MP Blade ²	When clicked, launches the Assign MP Blade window.
Edit Policies ²	When clicked, launches the Edit Policies window.
Export ²	When clicked, allows you to save table information to a file.
Notes: <ol style="list-style-type: none"> 1. Does not appear by default. To display the item, change the setting in the Column Settings window of the table option. See the <i>Hitachi Virtual Storage Platform G1000 System Administrator Guide</i> for the details of the window. 2. Appears when you click More Actions. 	

External Paths tab

Displays the external paths within the selected path group.

Item	Description
	<ul style="list-style-type: none"> • Warning: There are external paths whose status is not normal. You can check their status in the View External LUN Properties window. • Blockade: The external path is blocked.
QDepth	<p>Number of Read/Write commands that can be queued to the external volume. 8 is set by default.</p> <p>When Load Balance Mode is Extended Round-robin and the I/Os issued to the external volume are sequential, the number of Read/Write commands that can be queued at one time is the total of the QDepth values of all the external paths.</p>
I/O Timeout (sec.)	Number of seconds that should pass before I/O to the external volume times out. 15 seconds is the default.
Path Blockade Watch(sec.)	Time that will elapse from the time that a path goes down to the time when the external volume is blocked. 10 seconds is the default.
Edit External Path Configuration	When clicked, launches the Edit External Path Configuration window.
Edit Policies	When clicked, launches the Edit Policies window.
Export	When clicked, allows you to save table information to a file.

Add External Volumes wizard

Use this wizard to connect external volumes to VSP G1000.

See [Mapping an external volume on page 4-5](#) for instructions.

Each window in the wizard is identified below the wizard title. The windows are:

- [Select External Path Group window on page D-17](#)
- [Add External Volumes window on page D-19](#)
- [Add External Volumes confirmation window on page D-25](#)

Select External Path Group window

Part of the Add External Volumes wizard, use this window to select and set parameters for an external path group.

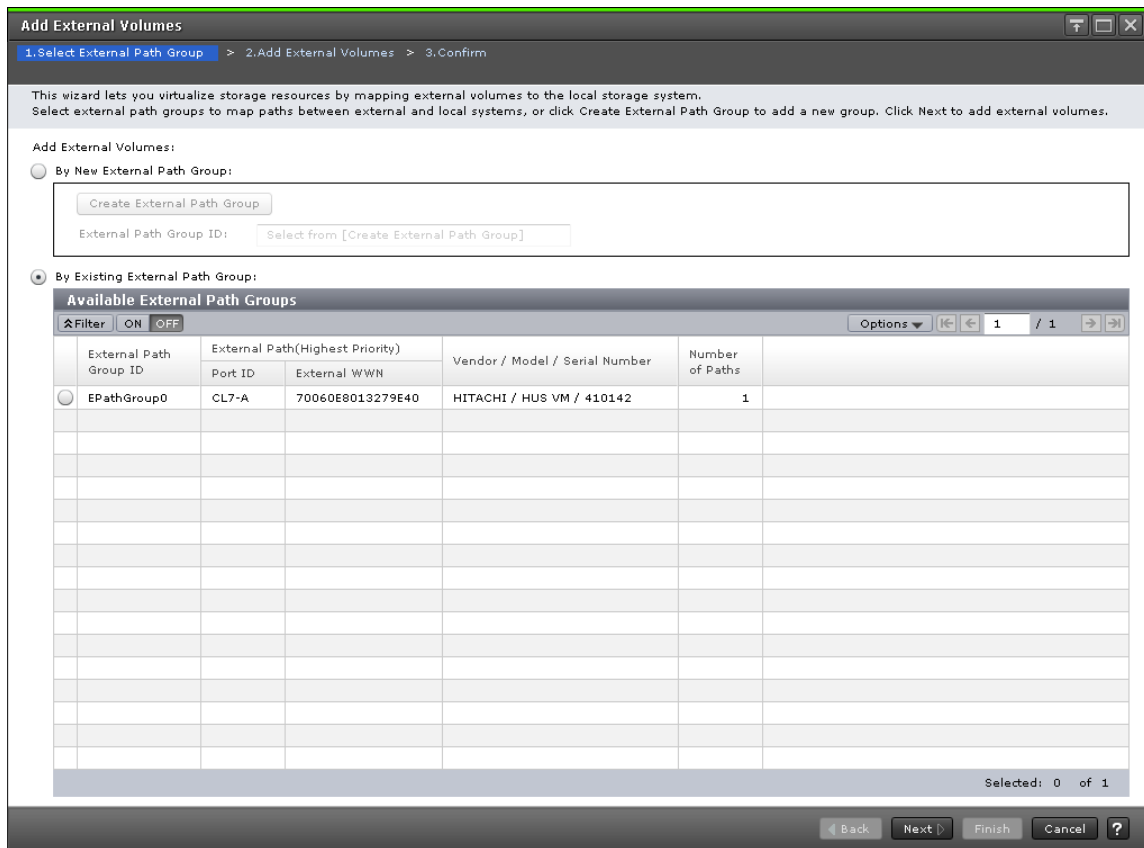

Item	Description
By New External Path Group.	Option for setting up a new external path group.
Create External Path Group	When clicked, launches the Create External Path Group window.
External Path Group ID	Number to identify the new external path group. The range can be from 0 to 63,231. Blank is the default.
By Existing External Path Group.	Option for using an existing external path group.
Available External Path Groups	External path groups for the ports assigned to the user.
External Path Group ID	Name of the external path group.
External Path (Highest Priority)	External path in the path group with the highest priority.
Port ID	Displays the external port of the local storage system.
External WWN	Displays the WWN of the external storage system. The external WWN shows the target port.
Vendor / Model / Serial Number	Identifying information for the external system.
Number of Paths	Number of external paths in the path group.

Add External Volumes window

Part of the **Add External Volumes** wizard, use this window to display discovered external volumes and to make related selections.

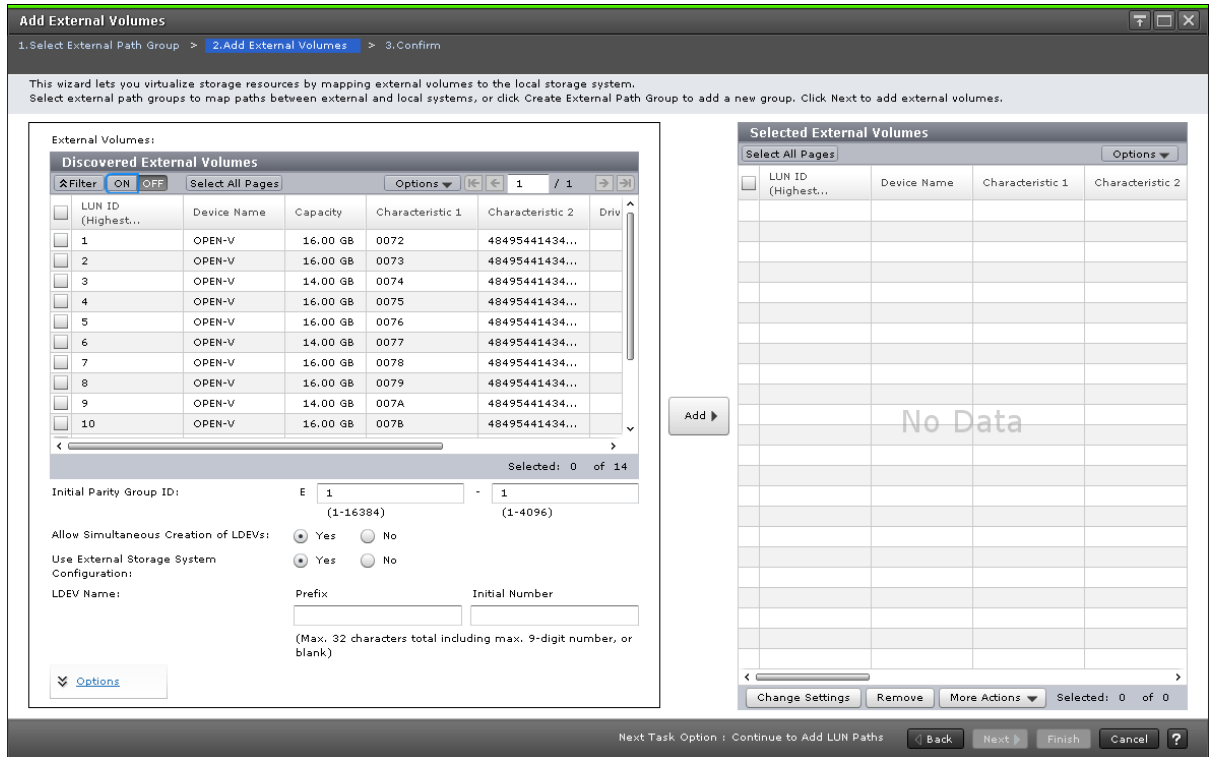

Item	Description
Discovered External Volumes	Volumes in the external system associated with the external port side of the external path and path group.
LUN ID(Highest Priority)	The external LUN with the highest priority. "?" indicates that an external volume is not found. In this case, confirm the connection with the external system, and then perform the operation again.
Device Name	Name of the storage system reported to the host by the external volume. The displayed name differs by vendor. For some Hitachi enterprise storage, this field displays emulation type.
Capacity	External volume capacity.
Characteristic 1	Identification number of the external volume. The value is used by UVM to identify the LUN across multiple paths. The value is provided by the external system and may reflect internal numbering.
Characteristic 2	Identification number of the external volume.
Drive Info	Information about the external volume's drive type. SATA displays when the external volume is a SATA drive of following storage systems. <ul style="list-style-type: none"> Virtual Storage Platform

Item	Description
	<ul style="list-style-type: none"> • Universal Storage Platform V/VM • HUS/AMS/WMS • SMS • Thunder 9500V <p>SSD displays when the external volume is the SSD of following storage systems.</p> <ul style="list-style-type: none"> • Hitachi Virtual Storage Platform G1000 • HUS VM Storage Platform • Virtual Storage Platform • Universal Storage Platform V/VM
Path Mode	<p>Displays operation mode of the external path.</p> <ul style="list-style-type: none"> • Single: Ordinarily, only one external path is used even if alternate paths are set, In Single mode, alternate paths are used only in case of maintenance work failure. • Multi: When alternate paths are set, external paths from several ports are simultaneously used with load balancing.
ALUA Settable	<p>Displays whether ALUA can be set as the Path Mode in the external storage system.</p> <ul style="list-style-type: none"> • Enable: Enables ALUA Mode. • Disable: Disables ALUA Mode.
Discovery Result	<p>Displays one of the following:</p> <ul style="list-style-type: none"> • Normal • An error code <p>When clicked, the link displays the Discovery Result Detail window with details of the search.</p>
Initial Parity Group ID	<p>An external volume group number and sequence number. Values range from 1 - 1 (default) to 16384 - 4096.</p>
Allow Simultaneous Creation of LDEVs	<p>LDEVs are automatically created in the internal volume when Yes is selected. If No is selected, you must create LDEVs manually.</p>
Use External Storage System Configuration	<p>If Yes is specified in "Allow Simultaneous Creation of LDEVs", the external volume's configuration for the LDEVs is used when Yes is selected. If No is selected, you must configure LDEVs manually.</p>
LDEV Name	<p>Requires a prefix character and initial number, 32 characters maximum (including the initial number).</p> <p>Numbering rule for Initial Number:</p> <p>1: total 9 numbers (1,2,3,...9)</p> <p>08: total 92 numbers (08,09,10,...99)</p> <p>23: total 77 numbers (23,24,25,...99)</p> <p>098: total 902 numbers (098,099,100...999)</p>

Item	Description
Options	Optional default settings for the external volume. Options can be affected by values entered in previous fields.
Initial LDEV ID	VSP G1000 searches from this number in ascending order and allocates the next available LDEV ID to the external volume. Ranges for each item: <ul style="list-style-type: none"> • LDKC: 00 • CU: From 00 (default) to FE. • DEV: The LDEV ID. From 00 (default) to FF. • Interval: Interval between LDEV IDs. From 0 (default) to 255.
View LDEV IDs	Shows used, available, and disabled LDEV IDs.
Initial SSID	SSID number. Range can be from 0004 (default) to FFFE.
View SSID	Shows current SSIDs. For information on the Edit SSIDs window, see the <i>Hitachi Virtual Storage Platform G1000 Provisioning Guide for Open Systems</i> or the <i>Hitachi Virtual Storage Platform G1000 Provisioning Guide for Mainframe Systems</i> .
Base Emulation Type	External system's emulation type. All supported emulation types except OPEN-L can be specified. See Editing external volume policies (settings) on page 5-2 for more information.
Number of LDEVs per External Volume	Number of LDEVs to be created in the local system when the volume is mapped. Depends on base emulation type.
Cache Partition	CLPR for accessing the external volume. The range can be from CLPR0 to CLPR31. The default is the value set in the Edit Policies window. See Editing external volume policies (settings) on page 5-2 for more information.
Cache Mode	<ul style="list-style-type: none"> • Enable: Write data from the host is propagated asynchronously • Disable: Write data from the host is propagated synchronously <p>Except the data written directly by the host, data (such as written by ShadowImage) will be propagated asynchronously regardless of the Cache Mode settings. If set to Disable, bind mode is not specified with Cache Residency Manager. The default is the value set in the Edit Policies window. See Cache use and external storage performance on page 2-6 for more information.</p>
Inflow Control	<ul style="list-style-type: none"> • Enable: Limits or prevents write data from being written to cache memory when the write operation cannot be performed. • Disable: Allows write data to be written to cache when the write operation cannot be performed.

Item	Description
	See Editing external volume policies (settings) on page 5-2 for more information.
Use ALUA as Path Mode	<p>Select whether ALUA is used as the Path Mode. The default is Enable if ALUA mode can be set as the Path Mode. Otherwise, the default is Disable. If the product name of an external storage system is displayed as (generic), the selected external volume or volumes is used by default.</p> <ul style="list-style-type: none"> • Enable: Enables ALUA mode. • Disable: Disables ALUA mode.
Load Balance Mode	<p>Select I/O load balance system for external storage system.</p> <ul style="list-style-type: none"> • Depend on the selected external volume(s): If Enable is set for ALUA Settable on the external volume, Normal Round-robin is set for Load Balance Mode automatically. If Disable is set for ALUA Settable, Disable is set for Load Balance Mode automatically. • Normal Round-robin: Performs load balance in round-robin system. • Extended Round-robin: Load balance system is automatically switched for sequential I/O and random I/O. • Disable: Performs I/O operation with a single path, without load balance. <p>The default is the value set in the Edit Policies window.</p> <p>If the product name of an external storage system is displayed as (generic), Depend on the selected external volume(s) is used by default.</p> <p>This item cannot be selected when the path mode of the external volume is Single or Disable is selected for Use ALUA as Path Mode.</p>
MP Blade	<p>MP blade for the external volume.</p> <ul style="list-style-type: none"> • Range is from MPB0 to MPB7. • Auto (default): Blade is automatically selected by the system. • Blade with lowest number is used when Auto cannot be selected.
Add	When clicked, moves selected volumes to the Selected External Volumes list.

Selected External Volumes

Displays selected external volumes.

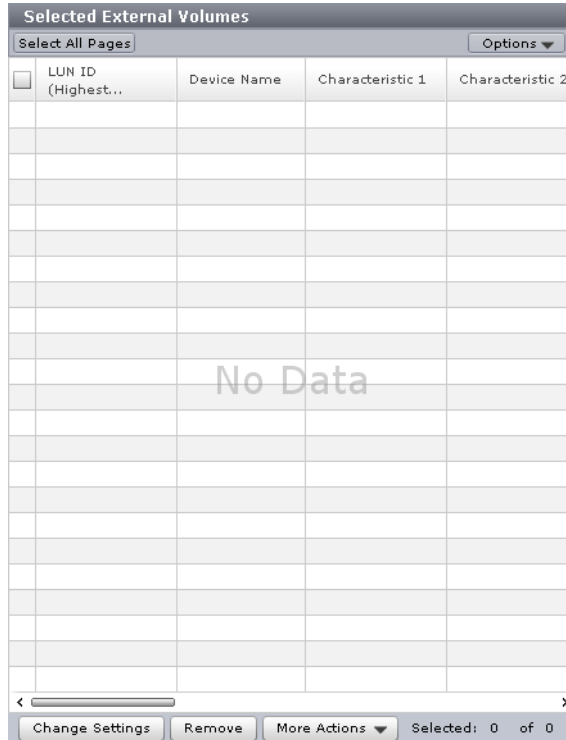

Item	Description
LUN ID(Highest Priority)	External volume's LUN with the highest priority.
Device Name	Name of the storage system reported to the host by the external volume. The displayed name differs by vendor. For some Hitachi enterprise storage, this field displays emulation type.
Characteristic 1	Identification number of the external volume. The value is used by UVM to identify the LUN across multiple paths. The value is provided by the external system and may reflect internal numbering.
Characteristic 2	External volume's identification number.
Drive Info	Information about the external volume's drive type. SATA displays when the external volume is a SATA drive of following storage systems. <ul style="list-style-type: none"> • Virtual Storage Platform • Universal Storage Platform V/VM • HUS/AMS/WMS • SMS • Thunder 9500V SSD displays when the external volume is the SSD of following storage systems. <ul style="list-style-type: none"> • Hitachi Virtual Storage Platform G1000 • HUS VM Storage Platform • Virtual Storage Platform • Universal Storage Platform V/VM

Item	Description
Parity Group ID	Parity group numbers.
Base Emulation Type	External volume's emulation type.
Top LDEV ID	External volume's top LDEV ID.
Top LDEV Name	External volume's top LDEV name.
Number of LDEVs	External volume's number of LDEVs.
Capacity	External volume's capacity.
SSID	SSIDs.
CLPR	CLPR used for accessing to the mapped external volume.
Cache Mode	<ul style="list-style-type: none"> • Enable: Write data from the host is propagated asynchronously • Disable: Write data from the host is propagated synchronously <p>See Cache use and external storage performance on page 2-6 for more information.</p>
Inflow Control	<ul style="list-style-type: none"> • Enable: Limits or prevents write data from being written to cache memory when the write operation cannot be performed. • Disable: Allows write data to be written to cache when the write operation cannot be performed. <p>See Editing external volume policies (settings) on page 5-2 for more information.</p>
Path Mode	<p>Displays operation mode of the external path.</p> <ul style="list-style-type: none"> • Single: Ordinarily, only one external path is used even if alternate paths are set, In Single mode, alternate paths are used only in case of maintenance work failure. • Multi: When alternate paths are set, external paths from several ports are simultaneously used with load balancing. • ALUA: When alternate paths are set, external paths from several ports are simultaneously used with load balancing. External paths connected to ports in Passive status are not used.
ALUA Permitted	<p>Displays whether ALUA can be set as the Path Mode in the local storage system.</p> <ul style="list-style-type: none"> • Enable: ALUA Mode is used. • Disable: ALUA Mode is not used.
Load Balance Mode	<p>Displays I/O load balance system for external storage system.</p> <ul style="list-style-type: none"> • Normal Round-robin: Performs load balance in round-robin system. • Extended Round-robin: Load balance system is automatically switched for sequential I/O and random I/O.

Item	Description
	<ul style="list-style-type: none"> Disable: Performs I/O operation with a single path, without load balance.
MP Blade ID	External volume's MP blade IDs.
Change Settings	When clicked, the Change Setting dialog box opens.
Remove	When clicked, removes external volumes from the Selected External Volumes table.
Edit SSIDs*	When clicked, the Edit SSIDs window opens and you can change the SSID of the selected external volume. For information on the Edit SSIDs window, see the <i>Hitachi Virtual Storage Platform G1000 Provisioning Guide for Open Systems</i> or the <i>Hitachi Virtual Storage Platform G1000 Provisioning Guide for Mainframe Systems</i> .
Path Detail*	When clicked, the External LUN Properties window opens and you can review the path details of the selected external volume.
LDEV Detail*	When clicked, the External LDEV Properties window opens and you can review the details of the LDEV to be created from the selected external volume.
* Appears when you click More Actions .	

Add External Volumes confirmation window

1. Select External Path Group > 2. Add External Volumes > 3. Confirm

Enter a name for the task. Confirm the settings in the list and click Apply to add task in Tasks queue for execution.

Task Name: (Max. 32 Characters)

Selected External Path Group		
External Path Group ID	Vendor / Model / Serial Number	
EPathGroup0	HITACHI / HUS VM / 410142	

Selected External Paths			
Priority	Port ID	External WWN	
1	CL7-A	70060E8013279E40	
Total: 1			

Selected External Volumes						
<input type="checkbox"/>	LUN ID (Highest...)	Device Name	Characteristic 1	Characteristic 2	Drive Info	Parity Group ID
<input type="checkbox"/>	1	OPEN-V	0072	48495441434...		E1-2
<input type="checkbox"/>	2	OPEN-V	0073	48495441434...		E1-3
<input type="checkbox"/>	3	OPEN-V	0074	48495441434...		E1-4
Total: 3						

Go to tasks window for status < Back Next > Apply Cancel ?

Item	Description
Task Name	Identifies the operation within the system when Apply is clicked. Allows you to track the status of the operation.
External Path Group ID	Name of the external path group.
Vendor / Model / Serial Number	Identifying information for the external system.
Priority	Priority of external paths.
Port ID	Displays the external port of the local storage system.
External WWN	Displays the WWN of the external storage system. The external WWN shows the target port.
LUN ID(Highest Priority)	The LUN which is connected to the external path with the highest priority.
Device Name	Name of the storage system reported to the host by the external volume. The displayed name differs by vendor. For some Hitachi enterprise storage, this field displays emulation type.
Capacity	External volume capacity.
Characteristic 1	Identification number of the external volume. The value is used by UVM to identify the LUN across multiple paths. The value is provided by the external system and may reflect internal numbering.
Characteristic 2	Identification number of the external volume.
Drive Info	Information about the external volume's drive type. SATA displays when the external volume is a SATA drive of following storage systems. <ul style="list-style-type: none"> • Virtual Storage Platform • Universal Storage Platform V/VM • HUS/AMS/WMS • SMS • Thunder 9500V SSD displays when the external volume is the SSD of following storage systems. <ul style="list-style-type: none"> • Hitachi Virtual Storage Platform G1000 • HUS VM Storage Platform • Virtual Storage Platform • Universal Storage Platform V/VM
Parity Group ID	Parity group numbers.
Base Emulation Type	External volume's emulation type.
Top LDEV ID	External volume's top LDEV ID.
Top LDEV Name	External volume's top LDEV name.
Number of LDEVs	External volume's number of LDEVs.
SSID	SSIDs.

Item	Description
CLPR	CLPR used for accessing to the mapped external volume.
Cache Mode	<ul style="list-style-type: none"> • Enable: Write data from the host is propagated asynchronously • Disable: Write data from the host is propagated synchronously See Cache use and external storage performance on page 2-6 for more information.
Inflow Control	<ul style="list-style-type: none"> • Enable: Limits or prevents write data from being written to cache memory when the write operation cannot be performed. • Disable: Allows write data to be written to cache when the write operation cannot be performed. See Editing external volume policies (settings) on page 5-2 for more information.
Path Mode	Displays operation mode of the external path. <ul style="list-style-type: none"> • Single: Ordinarily, only one external port is used even if alternate paths are set. In Single mode, alternate paths are used only in case of maintenance work failure. • Multi: When alternate paths are set, external paths from several ports are simultaneously used with load balancing. • ALUA: When alternate paths are set, external paths from several ports are simultaneously used with load balancing. External paths connected to ports in Passive status are not used.
ALUA Permitted	Displays whether ALUA can be set as the Path Mode in the local storage system. <ul style="list-style-type: none"> • Enable: ALUA Mode is used. • Disable: ALUA Mode is not used.
Load Balance Mode	Displays I/O load balance system for external storage system. <ul style="list-style-type: none"> • Normal Round-robin: Performs load balance in round-robin system. • Extended Round-robin: Load balance system is automatically switched for sequential I/O and random I/O. • Disable: Performs I/O operation with a single path, without load balance.
MP Blade ID	External volume's MP blade IDs.
LDEV Detail	Displays the External LDEV Properties window and you can review the details of the selected external volume.



Note: Information in this **Confirm** window assumes only a single task is executed. If multiple tasks are executed, the window displays all configuration items. For information on these items, return to the

configuration window by clicking **Back** and refer to the topic on each configuration window by clicking **Help**.

Edit Policies window

Use this window to change settings for mapped external volumes.

See [Editing external volume policies \(settings\) on page 5-2](#) for information.

The screenshot shows the 'Edit Policies' window with the following settings:

- Allow Simultaneous Creation of LDEVs: Yes No
- Use External Storage System Configuration: Yes No
- Base Emulation Type: Depend on the selected external volume(s)
- Number of LDEVs per External Volume: 1 (1)
- Cache Partition: 0:CLPRO
- Cache Mode: Enable Disable
- Inflow Control: Enable Disable
- Load Balance Mode: Normal Round-robin
- MP Blade: Auto

Buttons at the bottom: Apply, Cancel, ?

Item	Description
Allow Simultaneous Creation of LDEVs	LDEVs are automatically created in the internal volume when Yes is selected. If No is selected, you must create LDEVs manually.
Use External Storage System Configuration	If Yes is specified in "Allow Simultaneous Creation of LDEVs", the external volume's configuration for the LDEVs is used when Yes is selected. If No is selected, you must configure LDEVs manually.
Base Emulation Type	External system's emulation type. All supported emulation types except OPEN-L can be specified. See Editing external volume policies (settings) on page 5-2 for more information.
Number of LDEVs per External Volume	Number of LDEVs to be created in the local system when the volume is mapped. Depends on base emulation type.
Cache Partition	CLPR for accessing the external volume.

Item	Description
	See Editing external volume policies (settings) on page 5-2 for more information.
Cache Mode	<ul style="list-style-type: none"> • Enable: Write data from the host is propagated asynchronously • Disable: Write data from the host is propagated synchronously See Cache use and external storage performance on page 2-6 for more information.
Inflow Control	<ul style="list-style-type: none"> • Enable: Limits or prevents write data from being written to cache memory when the write operation cannot be performed. • Disable: Allows write data to be written to cache when the write operation cannot be performed. See Editing external volume policies (settings) on page 5-2 for more information.
Load Balance Mode	Select I/O load balance system for external storage system. <ul style="list-style-type: none"> • Normal Round-robin: Performs load balance in round-robin system. • Extended Round-robin: Load balance system is automatically switched for sequential I/O and random I/O. • Disable: Performs I/O operation with a single path, without load balance. The default is Normal Round-robin .
MP Blade	MP blade for the external volume. <ul style="list-style-type: none"> • Range is from MPB0 to MPB7. • Auto (default): Blade is automatically selected by the system. • Blade with lowest number is used when Auto cannot be selected.

Edit External Volumes wizard

Use this wizard to change settings for a mapped external volume.

The windows in the wizard are:

- [Edit External Volumes window on page D-30](#)
- [Edit External Volumes confirmation window on page D-31](#)

Edit External Volumes window

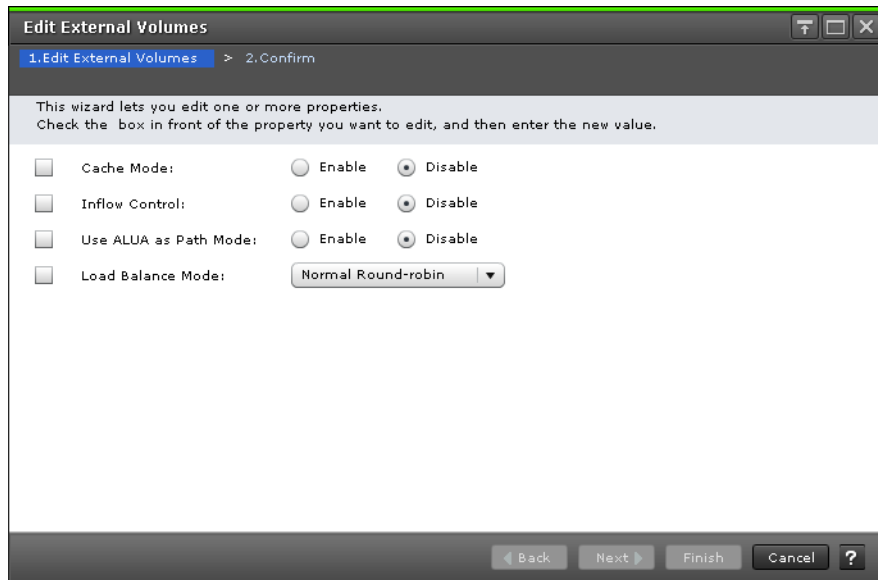

Item	Description
Cache Mode	<ul style="list-style-type: none"> • Enable: Write data from the host is propagated asynchronously. • Disable: Write data from the host is propagated synchronously. <p>See Cache use and external storage performance on page 2-6 for more information.</p>
Inflow Control	<ul style="list-style-type: none"> • Enable: Limits or prevents write data from being written to cache memory when the write operation cannot be performed. • Disable: Allows write data to be written to cache when the write operation cannot be performed. <p>See Editing external volume policies (settings) on page 5-2 for more information.</p>
Use ALUA as Path Mode	<p>Select whether ALUA is used as the Path Mode.</p> <ul style="list-style-type: none"> • Enable: Enables ALUA mode. • Disable: Disables ALUA mode. <p>The value that is set for the selected external volume is used as the default. If two or more external volumes with different values are selected, the item is placed in non-selected status. If the ALUA mode cannot be set for the selected external volume, Enable cannot be selected.</p>
Load Balance Mode	<p>Select I/O load balance system for external storage system.</p> <ul style="list-style-type: none"> • Normal Round-robin: Performs load balance in round-robin system. • Extended Round-robin: Load balance system is automatically switched for sequential I/O and random I/O.

Item	Description
	<ul style="list-style-type: none"> Disable: Performs I/O operation with a single path, without load balance. <p>The value that is set for the selected external volume is used as the default. If two or more external volumes with different values are selected, the item is placed in non-selected status.</p>

Edit External Volumes confirmation window

Item	Description
Parity Group ID	Displays parity group numbers.
Top LDEV ID	External volume's top LDEV ID.
Top LDEV Name	External volume's top LDEV name.
Cache Mode	<ul style="list-style-type: none"> Enable: Write data from the host is propagated asynchronously Disable: Write data from the host is propagated synchronously <p>When nondisruptive migration is specified as the Attribute, the cache modes are displayed.</p> <ul style="list-style-type: none"> Through: Transfers write and read requests from the host to the external storage system. The local system's cache is not used. Write Sync: Reflects write data from the host to the external storage system synchronously. If read or write is performed while data is being written to the external storage system, the read or write operation waits until the ongoing write operation is completed. <p>While cache mode operations are in progress, status is reported for cache mode changes.</p>

Item	Description
	<ul style="list-style-type: none"> • (Changing): Transition to the displayed cache mode is in progress. • (Error): Transition to the displayed cache mode has failed and maintenance work is required. <p>See Cache use and external storage performance on page 2-6 for more information.</p>
Inflow Control	<ul style="list-style-type: none"> • Enable: Limits or prevents write data from being written to cache memory when the write operation cannot be performed. • Disable: Allows write data to be written to cache when the write operation cannot be performed. <p>See Editing external volume policies (settings) on page 5-2 for more information.</p>
Path Mode	<p>Displays the external path of the external volume.</p> <ul style="list-style-type: none"> • Single: One external path is used, with alternate paths available in case of failure. • Multi: Multiple paths are used at the same time. • ALUA: Like Multi, all paths are used; however, they are not used when connected to ports in Passive status. For more information, see External paths on page 2-14.
ALUA Permitted	<p>Displays whether ALUA can be set as the Path Mode in the local storage system.</p> <ul style="list-style-type: none"> • Enable: ALUA Mode is used. • Disable: ALUA Mode is not used.
Load Balance Mode	<p>Displays I/O load balance system for external storage system.</p> <ul style="list-style-type: none"> • Normal Round-robin: Performs load balance in round-robin system. • Extended Round-robin: Load balance system is automatically switched for sequential I/O and random I/O. • Disable: Performs I/O operation with a single path, without load balance.

Edit External Path Configuration wizard

Use this wizard to add and remove external paths to a path group, and to raise and lower path priority.

See [Adding an external path to an existing path group on page 5-11](#) for instructions.

The windows in the wizard are:

- [Edit External Path Configuration window on page D-33](#)
- [Edit External Path Configuration confirmation window on page D-35](#)

Edit External Path Configuration window

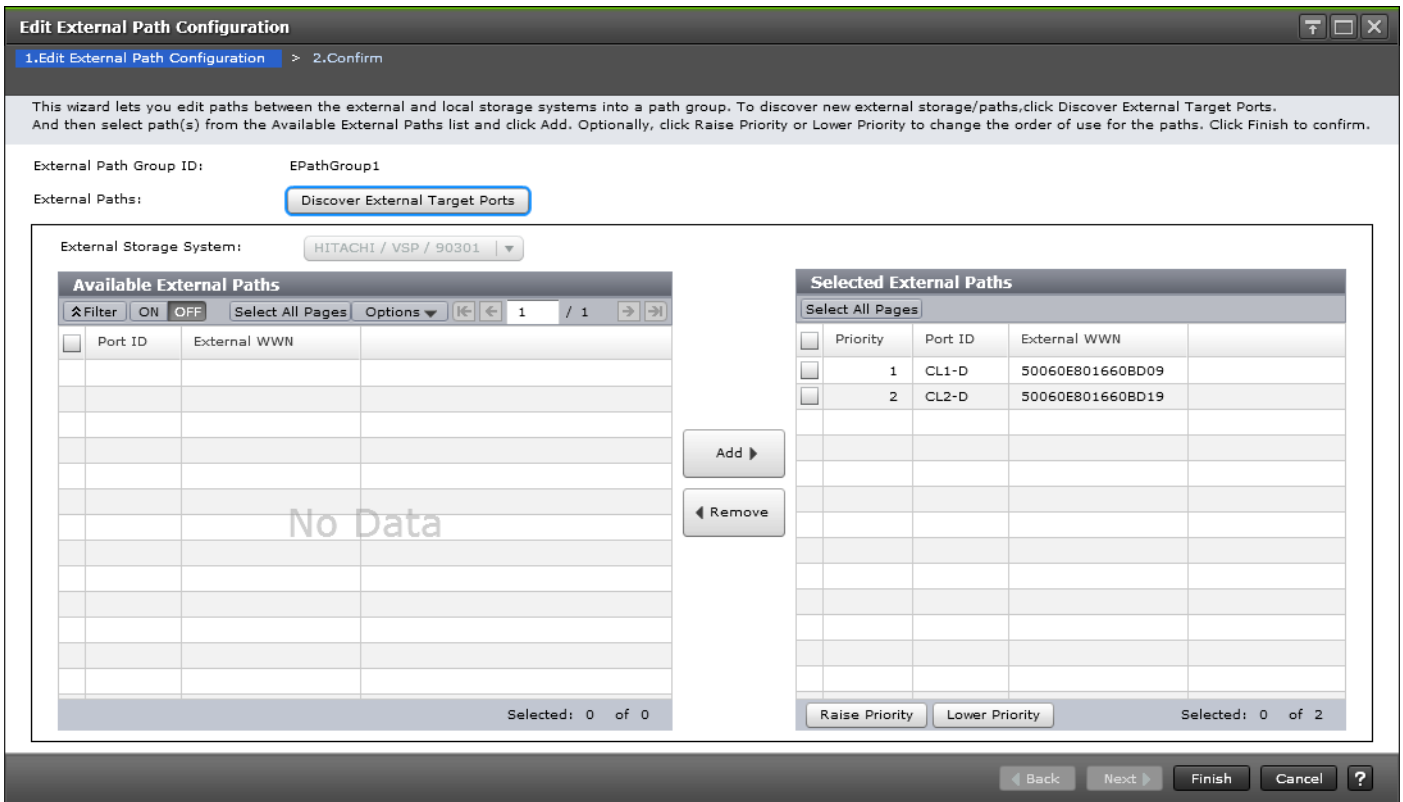

Only the external paths that are connected with the port assigned to the user are displayed.

Item	Description
External Path Group ID	Name of the external path group.
External Paths	External path information.
Discover External Target Ports	When clicked, opens the Discover External Target Ports window, which lists available external ports.
External Storage System	The external system selected (greyed out). If no system was selected, allows you to select the system from a list.
Available External Paths	
Port ID	Displays the external port of the local storage system.
External WWN	Displays the WWN of the external storage system. The external WWN shows the target port.
Add	When clicked, moves selected paths to the Selected External Paths list.

The following figure shows the **Selected External Paths** pane of the **Edit External Path Configuration** window.

Edit External Path Configuration confirmation window

Item	Description
Task Name	Identifies the operation within the system when Apply is clicked. Allows you to track the status of the operation.
External Path Group ID	Displays the name of the external path group.
Vendor / Model / Serial Number	Identifying information for the external system.
Priority	Priority of external paths.
Port ID	Displays the external port of the local storage system.
External WWN	Displays the WWN of the external storage system. The external WWN shows the target port.

Edit External WWNs wizard

Use this wizard to change the external system's WWN port setting.

See [Editing external WWN settings on page 5-9](#) for instructions.

The windows in the wizard are:

- [Edit External WWNs window on page D-36](#)
- [Edit External WWNs confirmation window on page D-37](#)

Edit External WWNs window

Item	Description
QDepth	Number of Read/Write commands that can be queued to the external volume. The numbers 2 through 128 can be entered. When two or more external paths with different values are selected, the field is blank. When Load Balance Mode is Extended Round-robin and the I/Os issued to the external volume are sequential, the number of Read/Write commands that can be queued at one time is the total of the QDepth values of all the external paths.
I/O Timeout (sec.)	Number of seconds that should pass before I/O to the external volume times out. The numbers 5 through 240 can be entered. When two or more external paths with different values are selected, the field is blank.
Path Blockade Watch (sec.)	Time that elapses from the time that a path goes down to the time when the external volume is blocked. The numbers 5 through 180 can be entered. When two or more external paths with different values are selected, the field is blank.



Caution: If you want to change multiple parameters for an external WWN more than once, wait until the currently applied task finishes, and then perform the next setting change. If you make a setting change for the next task before completing the last, the setting will be applied to the next task only. The result might be different from what you expected.

Edit External WWNs confirmation window

Item	Description
Port ID	Displays the external port of the local storage system.
External WWN	Displays the WWN of the external storage system. The external WWN shows the target port.
QDepth	Number of Read/Write commands that can be queued to the external volume. When Load Balance Mode is Extended Round-robin and the I/Os issued to the external volume are sequential, the number of Read/Write commands that can be queued at one time is the total of the QDepth values of all the external paths.
I/O Timeout (sec.)	Number of seconds that should pass before I/O to the external volume times out.
Path Blockade Watch(sec.)	Time that will elapse from the time that a path goes down to the time when the external volume is blocked.

Delete External Volumes wizard

Use this wizard to delete external volume mapping.

See [Deleting an external volume mapping on page 5-29](#) for instructions.

The windows in the wizard are:

- [Delete External Volumes window on page D-38](#)
- [Delete External Volumes confirmation window on page D-39](#)

Delete External Volumes confirmation window

Item	Description
Parity Group ID	Parity group numbers.
Top LDEV ID	External volume's top LDEV ID.
Top LDEV Name	External volume's top LDEV name.
Forcible Deletion	<p>Yes: The external volume will be forcibly deleted even if the connection to the external volume has not been disconnected.</p> <p>No: The external volume will be deleted after confirming that the connection to the external volume is disconnected.</p>

Disconnect External Paths wizard

Use this wizard to disconnect external paths.

See [Disconnecting an external path on page 5-13](#) for instructions.

The windows in the wizard are:

- [Disconnect External Paths window on page D-40](#)
- [Disconnect External Paths confirmation window on page D-40](#)

Disconnect External Paths window

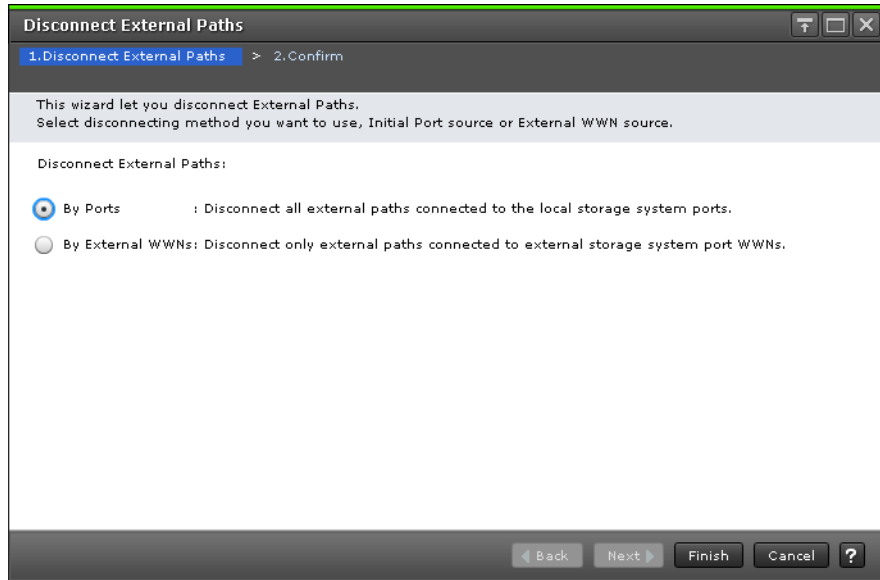

Item	Description
Disconnect External Paths	<ul style="list-style-type: none"> By Ports (default): Stops use of all the external paths connected to the specified port in the local system. By External WWNs: Stops use of all the external paths connected to the specified WWNs (ports) in the external system.

Disconnect External Paths confirmation window

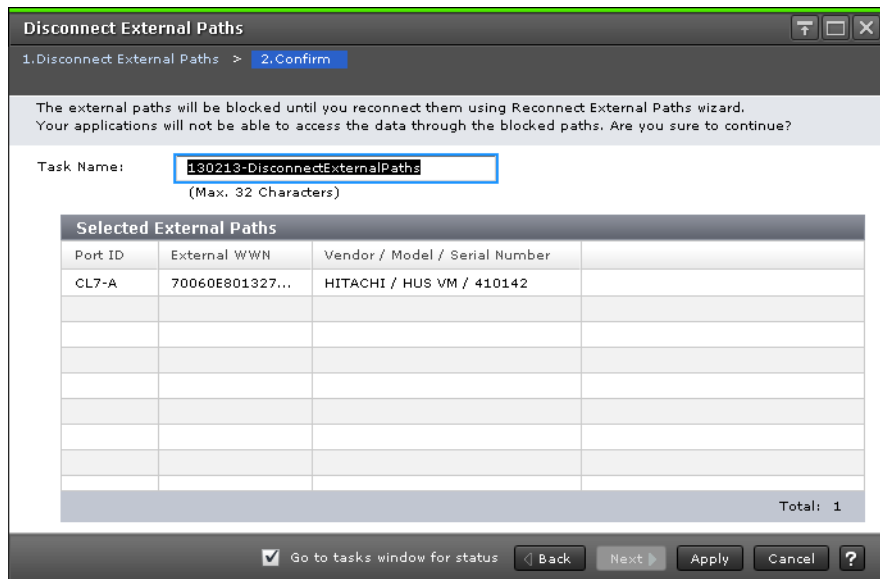

Item	Description
Port ID	Displays the external port of the local storage system.

Item	Description
External WWN	Displays the WWN of the external storage system. The external WWN shows the target port.
Vendor / Model / Serial Number	Identifying information for the external system.

Reconnect External Paths wizard

Use this wizard to reconnect external paths.

See [Reconnecting an external path on page 5-14](#) for instructions.

The windows in the wizard are:

- [Reconnect External Paths window on page D-41](#)
- [Reconnect External Paths confirmation window on page D-42](#)

Reconnect External Paths window

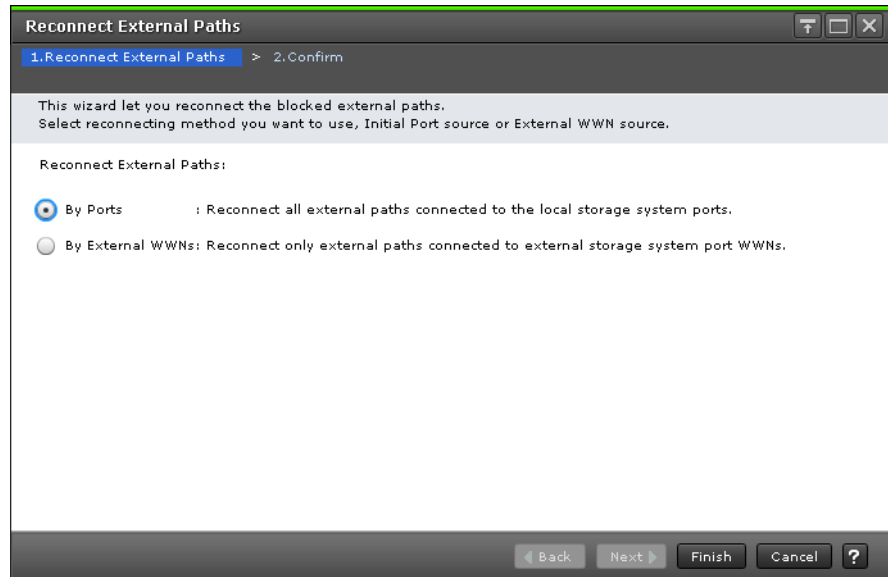

Item	Description
Reconnect External Paths	<ul style="list-style-type: none"> • By Ports (default): Reconnects all external paths connected to the specified port in the local system. • By External WWNs: Reconnects all external paths connected to the specified WWNs (ports) in the external system.

Reconnect External Paths confirmation window

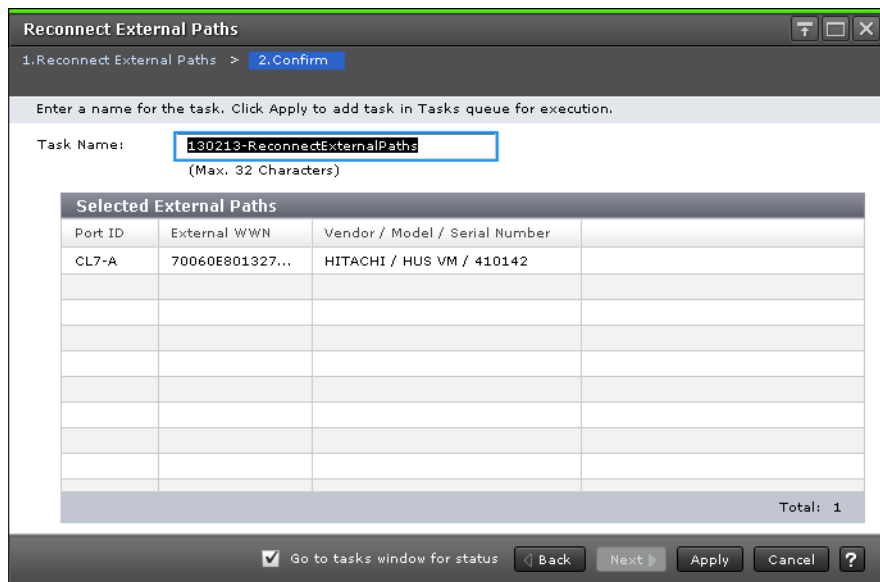

Selected External Paths table

Item	Description
Port ID	Displays the external port of the local storage system.
External WWN	Displays the WWN of the external storage system. The external WWN shows the target port.
Vendor / Model / Serial Number	Identifying information for the external system.

Discover External Target Ports window

Use this window to add or remove external ports for the external path.

This window is used in the following operations:

- [Mapping an external volume on page 4-5](#)
- [Adding an external path to an existing path group on page 5-11](#)

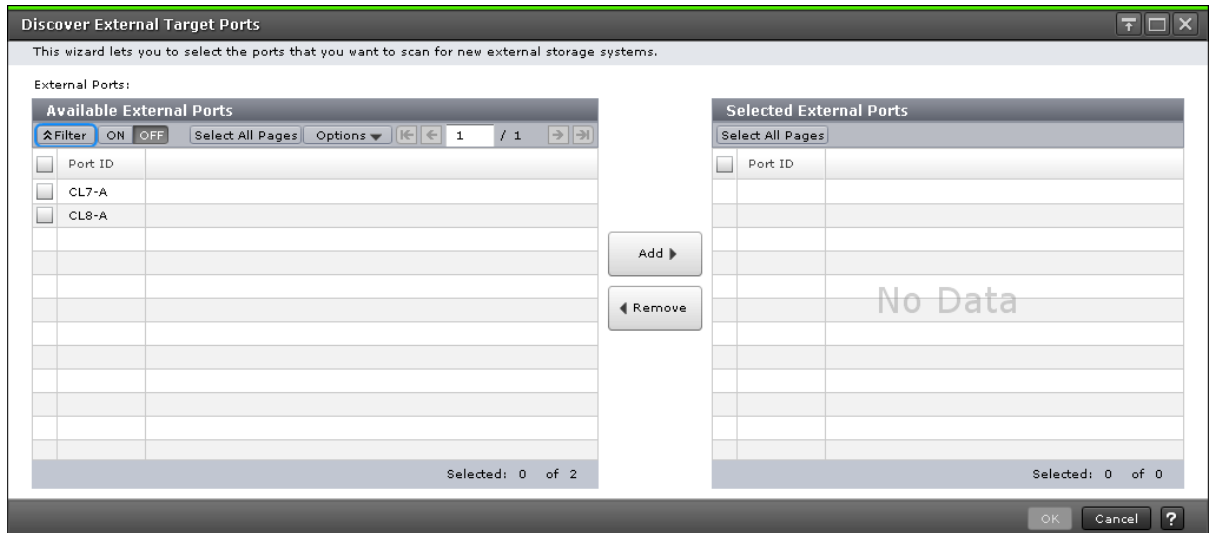

Only external ports assigned to the user display.

Item	Description
Available External Ports	
Port ID	Port number in the local system connecting to the external system.
Add	When clicked, moves selected paths to the Selected External Ports list.
Selected External Paths	
Remove	When clicked, removes the selected path from the Selected External Ports list.
Port ID	External system port number used in the external path.

Create External Path Group window

Use this window to create a new external path group.

This window is used in the operation, [Mapping an external volume on page 4-5](#).

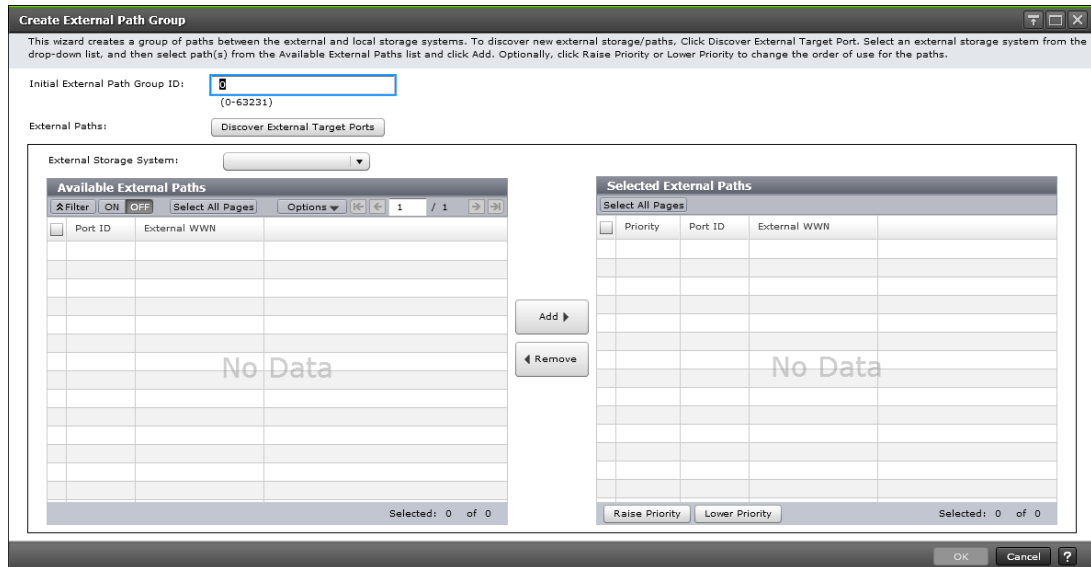

Only paths with ports assigned to the user can display.

Item	Description
Initial External Path Group ID	An initial ID for the path group. The storage system searches IDs in ascending order from this value and allocates an ID that can be used. The range can be from 0 to 63,231. 0 is the default.
Discover External Target Ports	When clicked, opens the Discover External Target Ports window.
External Storage System	The external system selected (greyed out). If no system was selected, allows you to select the system from a list.
Available External Paths	
Port ID	Displays the external port of the local storage system.
External WWN	Displays the WWN of the external storage system. The external WWN shows the target port.
Add	When clicked, moves selected paths to the Selected External Paths list.

The following figure shows the **Selected External Paths** pane of the **Create External Path Group** window.

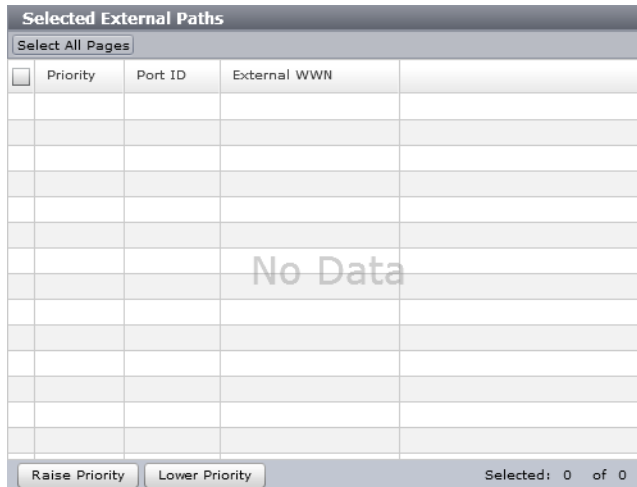

The following table provides descriptions of items in the **Selected External Paths** pane of the **Create External Path Group** window.

Item	Description
Selected External Paths (see preceding figure)	
Remove	When clicked, removes the selected path from the Selected External Paths list.
Priority	Priority of external paths.
Port ID	Displays the external port of the local storage system.
External WWN	Displays the WWN of the external storage system. The external WWN shows the target port.
Raise Priority	When clicked, raises the priority of the selected external path.
Lower Priority	When clicked, lowers the priority of the selected external path.

Change Settings window

Use this window to change the settings for selected external volumes.

This window is used in the operation, [Mapping an external volume on page 4-5](#).

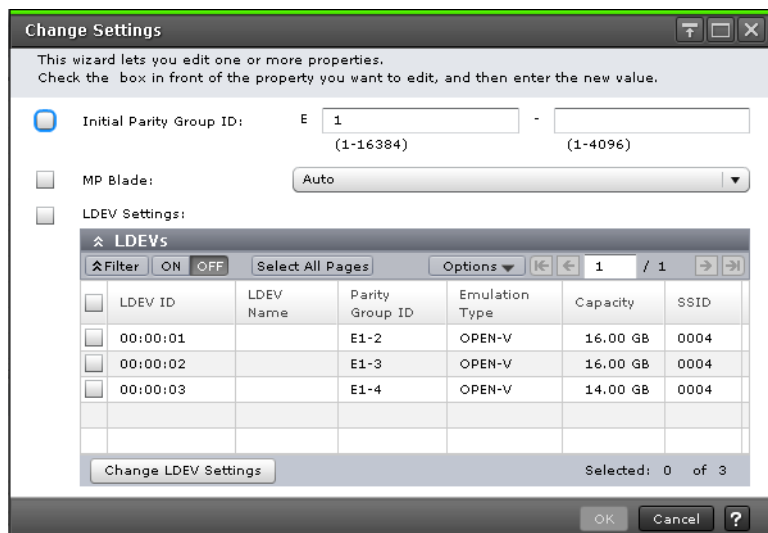

Item	Description
Initial Parity Group ID	An external volume group number and sequence number. Values range from 1 - 1 to 16384 - 4096. The default is the value set on the selected external volume. When two or more volumes with different values are selected, blank displays.
MP Blade	<ul style="list-style-type: none"> Range is from MPB0 to MPB7, but depends on the system configuration. Auto: You can select Auto when there are more than one MP blades whose auto assignment function is enabled. The default is the value set on the selected external volume. Blade with lowest number is used when Auto cannot be selected. When two or more volumes with different values are selected, blank displays.
LDEV Settings	If changes to LDEV settings are made, box must be checked to proceed.
LDEV ID	LDEV IDs allocated to the external volume.
LDEV Name	LDEV names.
Parity Group ID	Parity group numbers.
Emulation Type	LDEV emulation type.
Capacity	LDEV capacity.
SSID	SSIDs.
Resource Group Name (ID)	Name and ID of the resource group for the LDEV. ID is enclosed in parentheses.
Virtual Storage Machine	<ul style="list-style-type: none"> Model / Serial Number: Model and serial number of the virtual storage machine for the LDEV. Attribute: Virtual attribute of the LDEV. When the virtual attribute is not set, blank displays.

Item	Description
Change LDEV Settings	When clicked, opens Change LDEV Settings window.

View External LUN Properties window

Use this window to view settings and other details about external LUNs.

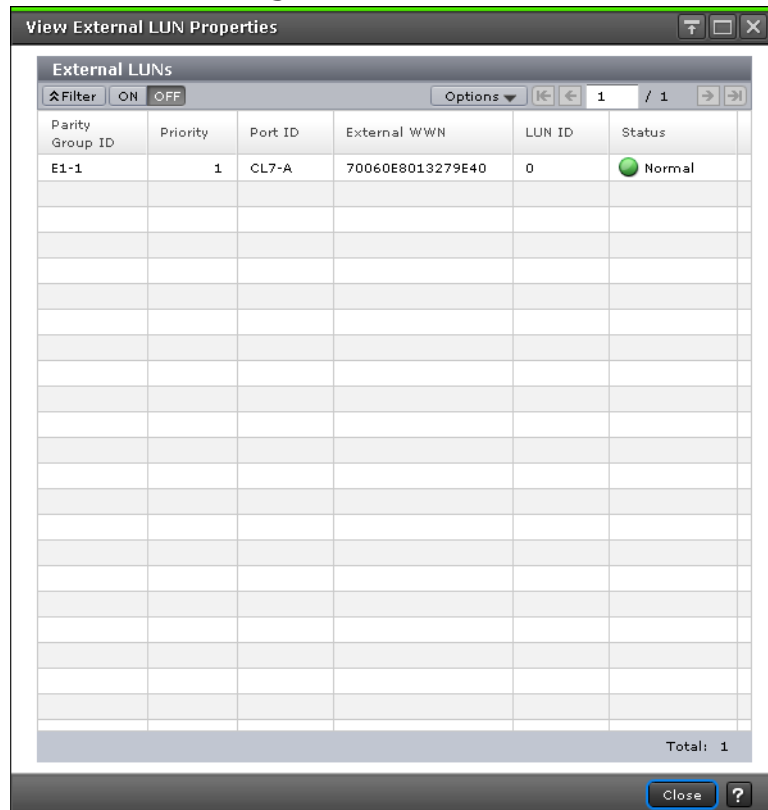

Item	Description
Parity Group ID	Parity group numbers.
Priority	Priority of external paths.
Port ID	Displays the external port of the local storage system.
External WWN	Displays the WWN of the external storage system. The external WWN shows the target port.
LUN ID	When the external path is connected to the selected external volume, the LUN ID displays.
Status	Status of external paths. <ul style="list-style-type: none"> • Unknown: The status of the mapping path is not known. • Checking: The system is checking the mapping path status. • Blockade: The mapping path is blocked. • Normal: There are no problems, the system is usable.

Item	Description
	<ul style="list-style-type: none"> • Disconnect: The external system or one of its mapped volumes has been intentionally disconnected. • External Device Setting Changed: An external system setting has been changed. For example, the path definition was deleted, or the external system itself was replaced by another device. • LDEV Size Reduced: The external volume's capacity was reduced. • Not Ready: The reply from the external system was NOT READY. • Illegal Request: The reply from the external system was ILLEGAL REQUEST. • Command Aborted: The reply from the external system was ABORTED COMMAND. • Busy: The external system is busy. • LDEV Reserved: The external system is reserved. • Response Error: The external system is blocked because of an abnormal reply. • Initiator Port: The port attribute of the external system has been changed to the initiator port. • Unknown Port: The port attribute of the external system is not known. • Cannot Detect Port: The path has been removed or the external system port cannot be found. • Timeout: Processing was retried because an abnormal reply was returned; however, processing has timed out. • Passive: The external system port is not active. Port status is normal but the port is not used for I/O. • Standby: The external system port is standing by. The port status is normal but cannot receive I/O. • Target Error: Port failures, such as controller blockade, are detected on the external system. • Unavailable: The reply from the external system was Unavailable. The external system demands to change the connected port. Once the status becomes Unavailable, the primary path is changed to an alternate path in Standby status. When the primary path is available, the status changes to Normal. • Backoff: The reply from the external system was Backoff. A temporary error has occurred in the external volume and the path is waiting for recovery. The primary path is not changed to the alternate path immediately. After recovery, the status changes to Normal. • Destage Failed: The writing of data from cache memory to the volume has failed.
Target Port Asymmetric Access State	<p>When the path mode is ALUA, the port state of the external storage system displays.</p> <ul style="list-style-type: none"> • Active/Optimized: The performance is in a good state. • Active/Non-Optimized: Data can be sent and received, but the performance is inferior to Active/Optimized. <p>A space displays in one of the following cases:</p> <ul style="list-style-type: none"> • The path mode is other than ALUA.

Item	Description
	<ul style="list-style-type: none"> Mapping of an external volume is not completed.

Reconnect External Storage Systems window

Use this window to reconnect the external storage system.

See [Reconnecting an external storage system and all mapped volumes on page 5-25](#) for instructions.

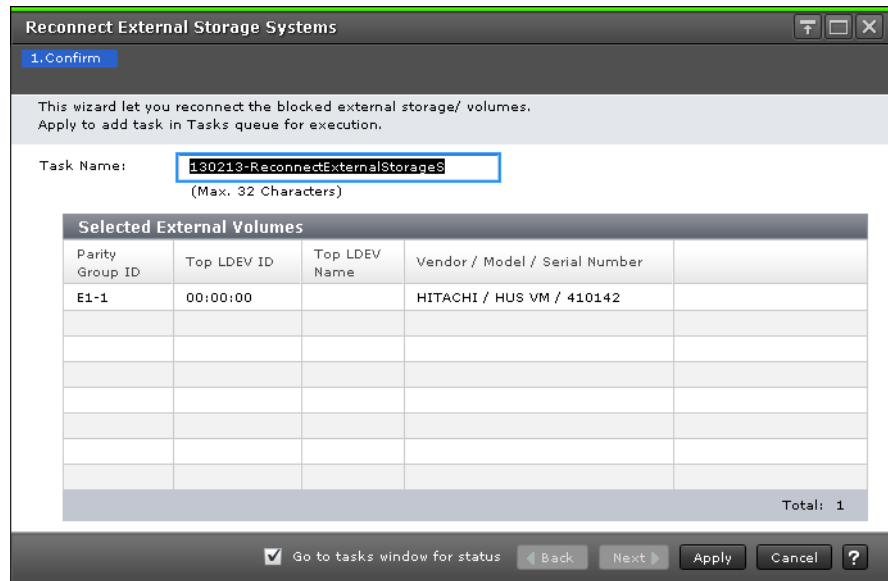

Item	Description
Parity Group ID	Parity group numbers.
Top LDEV ID	External volume's top LDEV ID. Blank displays when an LDEV is not created.
Top LDEV Name	External volume's top LDEV name. Blank displays when an LDEV is not created.
Vendor / Model / Serial Number	Identifying information for the external system.

Reconnect External Volumes window

Use this window to reconnect the external volume.

See [Reconnecting a single mapped volume on page 5-26](#) for instructions.

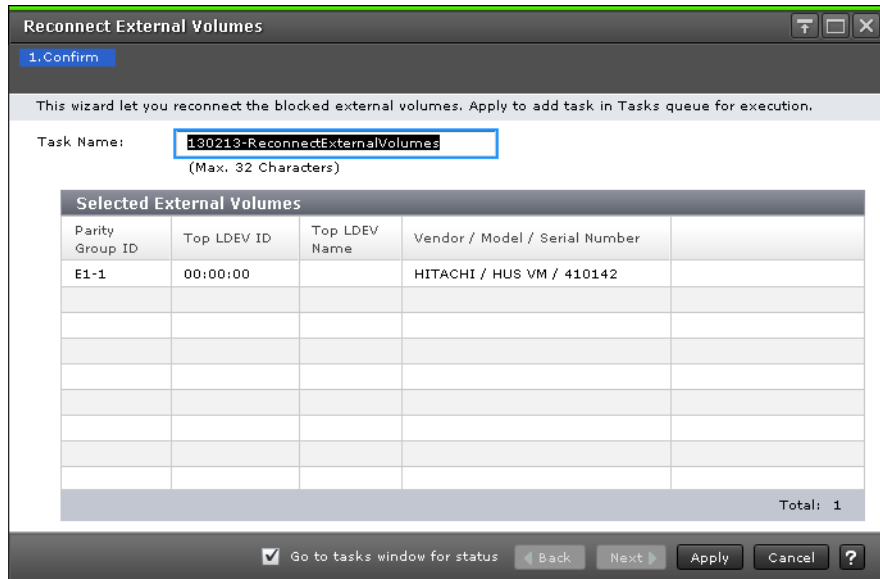

Item	Description
Parity Group ID	Parity group numbers.
Top LDEV ID	External volume's top LDEV ID. Blank displays when an LDEV is not created.
Top LDEV Name	External volume's top LDEV name. Blank displays when an LDEV is not created.
Vendor / Model / Serial Number	Identifying information for the external system.

Disconnect External Storage Systems window

Use this window to disconnect the storage system

See [Disconnecting an external storage system, all mapped volumes on page 5-21](#) for instructions.

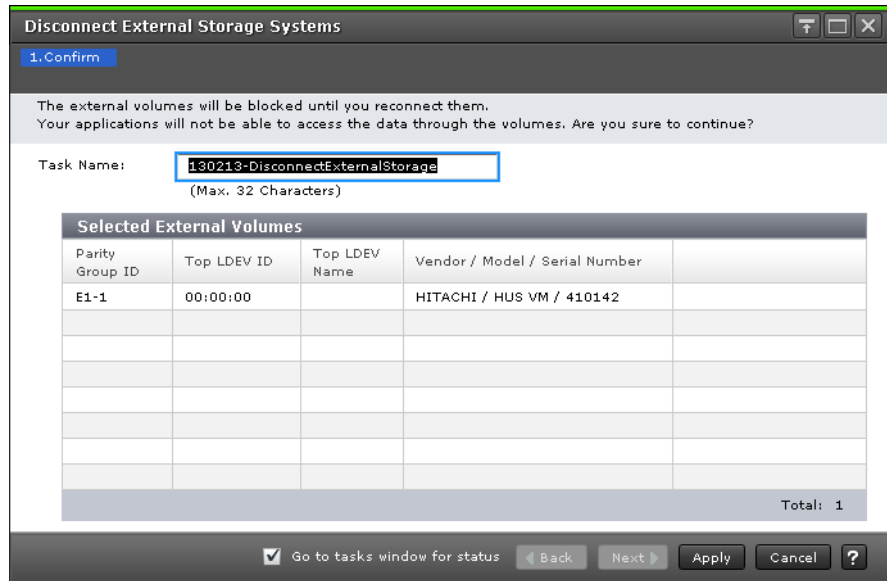

Item	Description
Parity Group ID	Parity group numbers.
Top LDEV ID	External volume's top LDEV ID. Blank displays when an LDEV is not created.
Top LDEV Name	External volume's top LDEV name. Blank displays when an LDEV is not created.
Vendor / Model / Serial Number	Identifying information for the external system.

Disconnect External Volumes window

Use this window to disconnect an external volume.

See [Disconnecting a single mapped volume on page 5-22](#) for instructions.

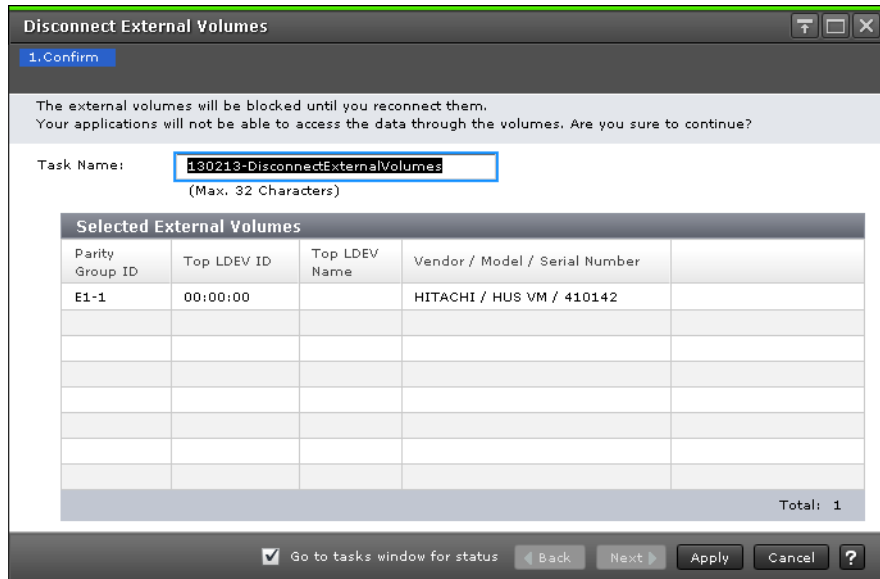

Item	Description
Parity Group ID	Parity group numbers.
Top LDEV ID	External volume's top LDEV ID. Blank displays when an LDEV is not created.
Top LDEV Name	External volume's top LDEV name. Blank displays when an LDEV is not created.
Vendor / Model / Serial Number	Identifying information for the external system.

Assign MP Blade wizard

Use this wizard to select an MP blade for the external volume.

See [Changing MP blade for external volume on page 5-5](#) for instructions.

The windows in this wizard are:

- [Assign MP Blade window on page D-53](#)
- [Assign MP Blade confirmation window on page D-53](#)

Assign MP Blade window

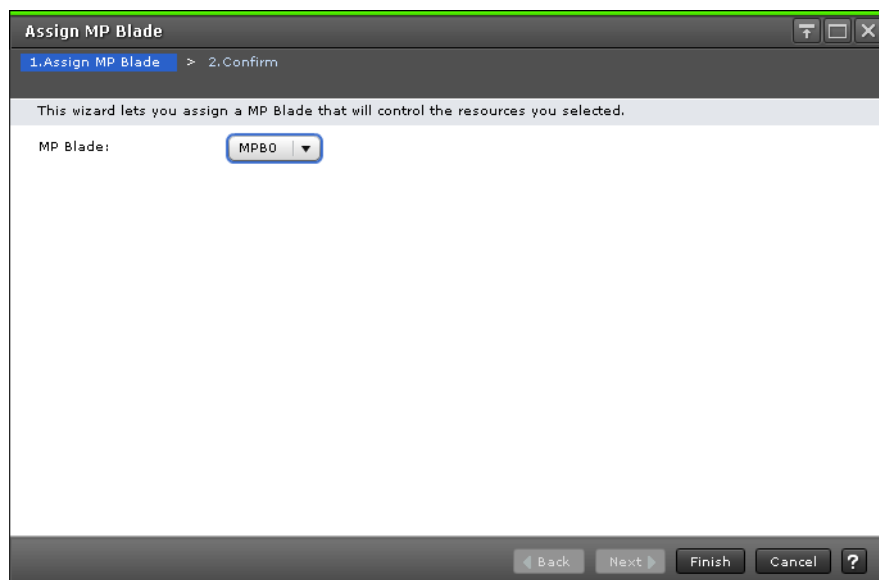

Item	Description
MP Blade	<p>MP blade for the external volume.</p> <ul style="list-style-type: none"> • Range is from MPB0 to MPB7. • The default is the value set on the selected external volume. When two or more volumes with different values are selected, blank displays. • Blade with lowest number is used when Auto cannot be selected.

Assign MP Blade confirmation window

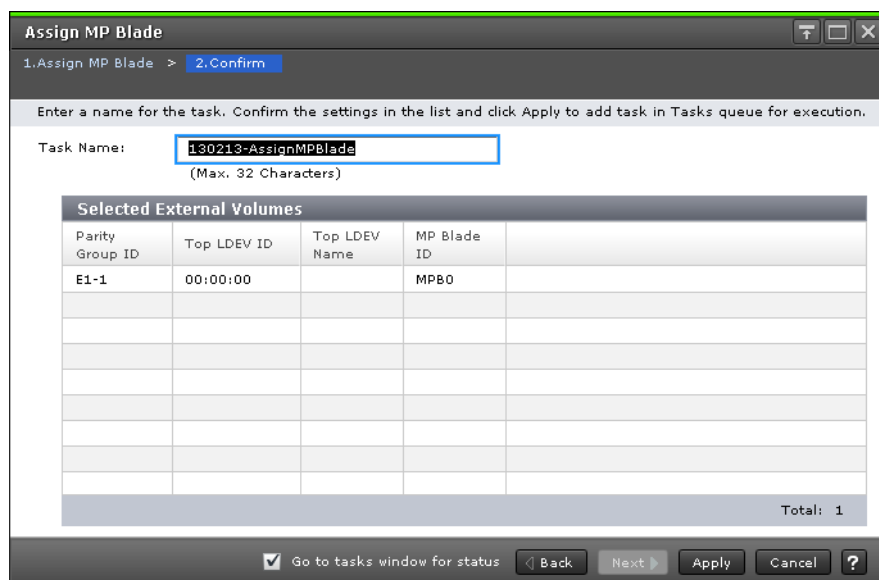

Item	Description
Parity Group ID	Parity group numbers.
Top LDEV ID	External volume's top LDEV ID. Blank displays when an LDEV is not created.
Top LDEV Name	External volume's top LDEV name. Blank displays when an LDEV is not created.
MP Blade ID	MP blade IDs allocated to the external volume.

External LDEV Properties window

Use this window to view settings for external LDEVs.

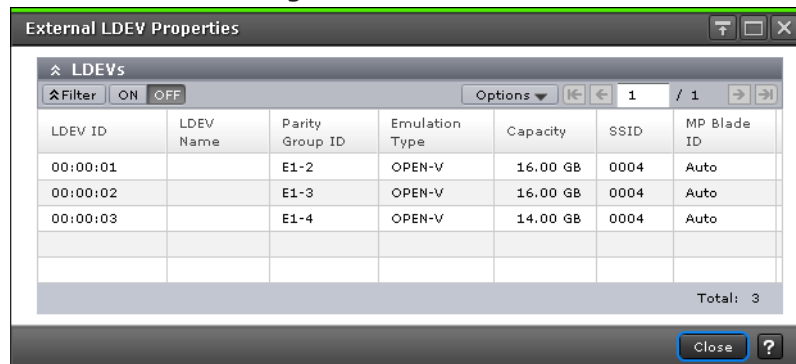

LDEVs table

Item	Description
LDEV ID	LDEV IDs allocated to the external volume.
LDEV Name	LDEV names.
Parity Group ID	Parity group numbers.
Emulation Type	LDEV's emulation type.
Capacity	LDEV's capacity.
SSID	LDEV's SSIDs.
MP Blade ID	MP blade IDs allocated to the LDEV.
Resource Group Name (ID)	Name and ID of the resource group for the LDEV. ID is enclosed in parentheses.
Virtual Storage Machine	<ul style="list-style-type: none"> Model / Serial Number: Model and serial number of the virtual storage machine for the LDEV. Attribute: Virtual attribute of the LDEV. When the virtual attribute is not set, blank displays.

Discovery Result Detail window

Use this window to view discover result settings and other details.

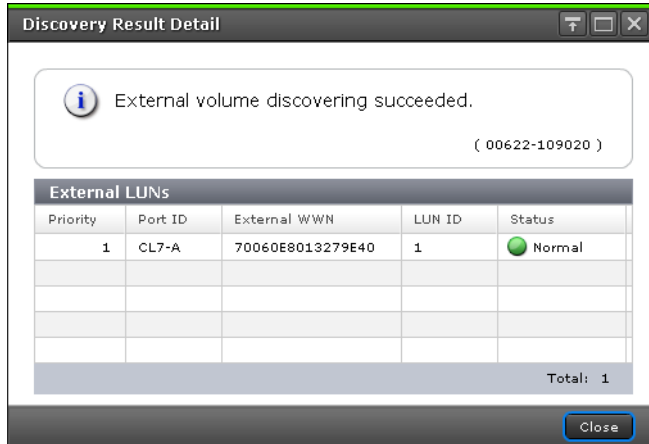

Item	Description
Priority	Priority of external paths.
Port ID	Displays the external port of the local storage system.
External WWN	Displays the WWN of the external storage system. The external WWN shows the target port.
LUN ID	When the external path is connected to the selected external volume, the LUN ID displays.
Status	Status of external paths. <ul style="list-style-type: none">• Unknown: The status of the mapping path is not known.• Normal: There are no problems, the system is usable.



Glossary

This glossary defines the special terms used in this document. Click the letter links below to navigate.

A

access attribute

The setting on a logical volume (mainframe or open-systems) that determines whether hosts can read and/or write to the volume.

alternate path

A secondary path (port, target ID, LUN) to a logical volume, in addition to the primary path, that is used as a backup in case the primary path fails.

ALUA

Asymmetric logical unit access

AMS

Hitachi Adaptable Modular Storage

APLB

active path load balancing

array

Another name for a storage system.

#	A	B	C	D	E	F	G	H	I	J	K	L	M	N	O	P	Q	R	S	T	U	V	W	X	Y	Z
---	-------------------	-------------------	-------------------	-------------------	-------------------	-------------------	-------------------	-------------------	-------------------	-------------------	-------------------	-------------------	-------------------	-------------------	-------------------	-------------------	-------------------	-------------------	-------------------	-------------------	-------------------	-------------------	-------------------	-------------------	-------------------	-------------------

B

bind mode

In bind mode the Cache Residency Manager extents are used to hold read and write data for specific extents on volumes. Data written to the Cache Residency Manager bind area is not destaged to the drives. For bind mode, all targeted read and write data is transferred at host data transfer speed.

blade

A computer module, generally a single circuit board, used mostly in servers.

C

cache logical partition (CLPR)

Consists of virtual cache memory that is set up to be allocated to different hosts in contention for cache memory.

capacity

The amount of data storage space available on a physical storage device.

CCI

Command Control Interface

CHA

channel adapter. Another name for a front-end director (FED).

channel path

The communication path between a channel and a control unit. A channel path consists of the physical channel path and the logical path.

CLI

command line interface

CLPR

cache logical partition

command device

A dedicated logical volume used only by Command Control Interface to interface with the storage system. Can be shared by several hosts.

custom volume (CV)

A customized (variable-sized) volume. The size is defined when Virtual LVI/Virtual LUN is used.

#	A	B	C	D	E	F	G	H	I	J	K	L	M	N	O	P	Q	R	S	T	U	V	W	X	Y	Z
---	-------------------	-------------------	-------------------	-------------------	-------------------	-------------------	-------------------	-------------------	-------------------	-------------------	-------------------	-------------------	-------------------	-------------------	-------------------	-------------------	-------------------	-------------------	-------------------	-------------------	-------------------	-------------------	-------------------	-------------------	-------------------	-------------------

CVS

custom volume size

D

device

A physical or logical unit with a specific function.

device emulation

Indicates the type of logical volume. Mainframe device emulation types provide logical volumes of fixed size, called logical volume images (LVIs), which contain EBCDIC data in CKD format. Typical mainframe device emulation types include 3390-9 and 3390-M. Open-systems device emulation types provide logical volumes of variable size, called logical units (LUs), that contain ASCII data in FBA format. The typical open-systems device emulation type is OPEN-V.

DP

Hitachi Dynamic Provisioning

DP-VOL

Dynamic Provisioning-virtual volume. A virtual volume with no memory space used by Dynamic Provisioning.

dynamic provisioning

An approach to managing storage. Instead of "reserving" a fixed amount of storage, it removes capacity from the available pool when data is actually written to disk. Dynamic provisioning is also referred to as thin provisioning.

E

emulation

The operation of the Hitachi RAID storage system to emulate the characteristics of a different storage system. For device emulation the mainframe host "sees" the logical devices on the RAID storage system as 3390-x devices. For controller emulation the mainframe host "sees" the control units (CUs) on the RAID storage system as 2105 or 2107 controllers.

ExG

external volume group

external port

A fibre-channel port that is configured to be connected to an external storage system for Universal Volume Manager operations.

#	A	B	C	D	E	F	G	H	I	J	K	L	M	N	O	P	Q	R	S	T	U	V	W	X	Y	Z
---	-------------------	-------------------	-------------------	-------------------	-------------------	-------------------	-------------------	-------------------	-------------------	-------------------	-------------------	-------------------	-------------------	-------------------	-------------------	-------------------	-------------------	-------------------	-------------------	-------------------	-------------------	-------------------	-------------------	-------------------	-------------------	-------------------

external volume

A logical volume with data that resides on drives which are physically located outside the Hitachi RAID storage system.

external volume group (ExG)

A set of mapped external volumes that is managed as a group. External volumes can be registered to external volume groups during the mapping process to enable simplified management of the external volumes.

F**failover**

The process of switching operations from the primary path or host to a secondary path or host when the primary path or host fails.

FCIP

fibre-channel internet protocol

H**HDS**

Hitachi Data Systems

host group

A group of hosts of the same operating system platform.

host mode

Operational modes that provide enhanced compatibility with supported host platforms. Used with fibre-channel ports on RAID storage systems.

host mode option

Additional options for fibre-channel ports on RAID storage systems. Provide enhanced functionality for host software and middleware.

I**initial copy**

A copy operation that copies all data on the primary volume of a copy pair to the secondary volume of the pair. An initial copy operation is performed when a copy pair is created.

#	A	B	C	D	E	F	G	H	I	J	K	L	M	N	O	P	Q	R	S	T	U	V	W	X	Y	Z
---	-------------------	-------------------	-------------------	-------------------	-------------------	-------------------	-------------------	-------------------	-------------------	-------------------	-------------------	-------------------	-------------------	-------------------	-------------------	-------------------	-------------------	-------------------	-------------------	-------------------	-------------------	-------------------	-------------------	-------------------	-------------------	-------------------

internal volume

A logical volume with data that resides on drives which are physically located within the storage system.

L**LDEV**

logical device

logical device (LDEV)

An individual logical data volume (on multiple drives in a RAID configuration) in the storage system. An LDEV may or may not contain any data and may or may not be defined to any hosts. Each LDEV has a unique identifier or "address" within the storage system composed of the logical disk controller (LDKC) number, control unit (CU) number, and LDEV number. The LDEV IDs within a storage system do not change. An LDEV formatted for use by open-systems hosts is called a logical unit (LU).

logical partition (LPAR)

A subset of a system's hardware resources that is virtualized as a separate system. For a storage system, logical partitioning can be applied to cache memory or storage capacity.

logical unit (LU)

A logical volume that is configured for use by open-systems hosts (for example, OPEN-V).

logical unit (LU) path

The path between an open-systems host and a logical unit.

logical volume

A logical device (LDEV), or a set of concatenated LDEVs in the case of LUSE, that has been defined to one or more hosts as a single data storage unit. A mainframe volume is called a logical volume image (LVI), and an open-systems volume is called a logical unit. (LU).

LU

logical unit

LUN

logical unit number

LUNM

Hitachi LUN Manager

LV

logical volume

#	A	B	C	D	E	F	G	H	I	J	K	L	M	N	O	P	Q	R	S	T	U	V	W	X	Y	Z
---	-------------------	-------------------	-------------------	-------------------	-------------------	-------------------	-------------------	-------------------	-------------------	-------------------	-------------------	-------------------	-------------------	-------------------	-------------------	-------------------	-------------------	-------------------	-------------------	-------------------	-------------------	-------------------	-------------------	-------------------	-------------------	-------------------

LVM

Logical Volume Manager; logical volume management.

M

multi-pathing

A performance and fault-tolerant technique that uses more than one physical connection between the storage system and host system. Also called multipath I/O.

N

NSC

Hitachi TagmaStore® Network Storage Controller

O

OEM

original equipment manufacturer

P

pair

Two logical volumes in a replication relationship in which one volume contains original data to be copied and the other volume contains the copy of the original data. The copy operations can be synchronous or asynchronous, and the pair volumes can be located in the same storage system (in-system replication) or in different storage systems (remote replication).

pair status

Indicates the condition of a copy pair. A pair must have a specific status for specific operations. When an operation completes, the status of the pair changes to the new status.

path mode

Mode that indicates how a path is used between local and external storage systems. The path modes are multi, single, and ALUA.

physical device

A data drive.

#	A	B	C	D	E	F	G	H	I	J	K	L	M	N	O	P	Q	R	S	T	U	V	W	X	Y	Z
---	-------------------	-------------------	-------------------	-------------------	-------------------	-------------------	-------------------	-------------------	-------------------	-------------------	-------------------	-------------------	-------------------	-------------------	-------------------	-------------------	-------------------	-------------------	-------------------	-------------------	-------------------	-------------------	-------------------	-------------------	-------------------	-------------------

pool

A set of volumes that is reserved for storing Thin Image data or Dynamic Provisioning write data.

pool volume (pool-VOL)

A logical volume that is reserved for storing snapshot data for Thin Image operations or write data for Dynamic Provisioning.

port attribute

Indicates the type of fibre-channel port: target, RCU target, or initiator.

primary volume (P-VOL)

The volume in a copy pair that contains the original data to be replicated. The data in the primary volume is duplicated synchronously or asynchronously on the secondary volume.

The following Hitachi products use the term P-VOL: ShadowImage, ShadowImage for Mainframe, TrueCopy, Universal Replicator, Universal Replicator for Mainframe, and High Availability Manager.

P-VOL

primary volume

R**VSP G1000**

Hitachi Virtual Storage Platform G1000

RAID

redundant array of inexpensive disks

RAID group

A redundant array of inexpensive drives (RAID) that have the same capacity and are treated as one group for data storage and recovery. A RAID group contains both user data and parity information, which allows the user data to be accessed in the event that one or more of the drives within the RAID group are not available. The RAID level of a RAID group determines the number of data drives and parity drives and how the data is "striped" across the drives. For RAID1, user data is duplicated within the RAID group, so there is no parity data for RAID1 RAID groups.

A RAID group can also be called an array group or a parity group.

RAID level

The type of RAID implementation. RAID levels include RAID0, RAID1, RAID2, RAID3, RAID4, RAID5 and RAID6.

#	A	B	C	D	E	F	G	H	I	J	K	L	M	N	O	P	Q	R	S	T	U	V	W	X	Y	Z
---	-------------------	-------------------	-------------------	-------------------	-------------------	-------------------	-------------------	-------------------	-------------------	-------------------	-------------------	-------------------	-------------------	-------------------	-------------------	-------------------	-------------------	-------------------	-------------------	-------------------	-------------------	-------------------	-------------------	-------------------	-------------------	-------------------

remote control unit (RCU)

A storage system at a secondary or remote site that is configured to receive remote I/Os from one or more storage systems at the primary or main site.

remote copy

Another name for remote replication.

remote replication

Data replication configuration in which the storage system that contains the original data is at a local site and the storage system that contains the copy of the original data is at a remote site. TrueCopy and Universal Replicator provide remote replication.

S**SATA**

serial Advanced Technology Attachment

secondary volume

The volume in a copy pair that is the copy of the original data on the primary volume (P-VOL). The following Hitachi products use the term "secondary volume": ShadowImage, TrueCopy, Universal Replicator.

service information message (SIM)

SIMs are generated by a RAID storage system when it detects an error or service requirement. SIMs are reported to hosts and displayed on Storage Navigator.

snapshot

A point-in-time copy of a data volume in a storage system.

SNMP

simple network management protocol

SOM

system option mode (SOM)

SSD

solid-state drive. Another name for a flash drive.

SSID

storage subsystem ID. SSIDs are used for reporting information from the CU to the mainframe operating system. Each group of 64 or 256 volumes requires one SSID, so there are one or four SSIDs per CU image. The user-specified SSIDs are assigned during storage system installation and must be unique to all connected host operating environments.

#	A	B	C	D	E	F	G	H	I	J	K	L	M	N	O	P	Q	R	S	T	U	V	W	X	Y	Z
---	-------------------	-------------------	-------------------	-------------------	-------------------	-------------------	-------------------	-------------------	-------------------	-------------------	-------------------	-------------------	-------------------	-------------------	-------------------	-------------------	-------------------	-------------------	-------------------	-------------------	-------------------	-------------------	-------------------	-------------------	-------------------	-------------------

S-VOL

secondary volume

system option mode (SOM)

Additional operational parameters for the Unified Storage VM storage systems that enable the storage system to be tailored to unique customer operating requirements. SOMs are set on the service processor.

T

TagmaStore USP

Hitachi TagmaStore® Universal Storage Platform

target port

A fibre-channel port that is configured to receive and process host I/Os.

TC

Hitachi TrueCopy®

U

UR

Hitachi Universal Replicator

URz

Hitachi Universal Replicator for Mainframe

USP VM

Hitachi Universal Storage Platform VM

USP V/VM

Hitachi Universal Storage Platform V/VM

UVM

Hitachi Universal Volume Manager

V

virtual device (VDEV)

A group of logical devices (LDEVs) in a RAID group. A VDEV typically consists of some fixed volumes (FVs) and some free space. The number of fixed volumes is determined by the RAID level and device emulation type.

#	A	B	C	D	E	F	G	H	I	J	K	L	M	N	O	P	Q	R	S	T	U	V	W	X	Y	Z
---	-------------------	-------------------	-------------------	-------------------	-------------------	-------------------	-------------------	-------------------	-------------------	-------------------	-------------------	-------------------	-------------------	-------------------	-------------------	-------------------	-------------------	-------------------	-------------------	-------------------	-------------------	-------------------	-------------------	-------------------	-------------------	-------------------

Virtual LUN volume

A custom-size volume with a size defined when Virtual LUN is used. Also called a custom volume (CV).

virtual volume

A storage system volume, also referred to as V-VOL, that has no physical memory space. V-VOLs are used as secondary volumes for Thin Image. VOLs that are used for Dynamic Provisioning, Dynamic Provisioning for Mainframe, Dynamic Tiering, or Dynamic Tiering for Mainframe are also called DP-VOLs.

VLL

Virtual LUN

volume

A logical device (LDEV) that has been defined to one or more hosts as a single data storage unit. A mainframe volume is called a logical volume image (LVI). An open-systems volume is called a logical unit (LU).

V-VOL

virtual volume

W**WMS**

Hitachi Workgroup Modular Storage

WWN

worldwide name

#	A	B	C	D	E	F	G	H	I	J	K	L	M	N	O	P	Q	R	S	T	U	V	W	X	Y	Z
---	-------------------	-------------------	-------------------	-------------------	-------------------	-------------------	-------------------	-------------------	-------------------	-------------------	-------------------	-------------------	-------------------	-------------------	-------------------	-------------------	-------------------	-------------------	-------------------	-------------------	-------------------	-------------------	-------------------	-------------------	-------------------	-------------------

Index

A

accessing data in an external volume 2-5
Add External Volume wizard D-17
adding an external path 5-11
alternate paths 2-14

C

Cache Mode info 5-3
Cache Mode setting 4-10
Cache Residency Manager 3-2
capacity 2-8
customer support xiii

D

deleting volume mapping 5-29
destaging data 5-3
disconnecting an external path 5-13
disconnecting an external volume 5-22
disconnecting external volumes 5-21
Dynamic Provisioning 3-3

E

edit settings for one ext. volume 5-5
editing external volume policies 5-4
emulation type
 and LDEV capacity listing 2-10
external paths
 adding 5-11
 detaching a channel adapter 5-17
 disconnecting 5-13

monitoring 5-2
planning 2-14
reconnecting 5-14
removing and replacing 5-17
status, troubleshooting 6-4
supported configurations 2-20

External Storage

mapping external volumes 4-5

External Storage window D-3

external systems

abbreviation in Stor. Nav. 2-17
disconnecting 5-21
listing for remote command devices B-2
path modes for 2-16
planning 2-4
powering off, on 5-31
supported A-1

external volume groups, planning 2-8

external volumes

adjusting capacity 2-12
deleting mapping for 5-29
disconnecting all 5-21
disconnecting one 5-22
editing policies 5-4
mapping procedure 4-5
monitoring 5-2
planning for 2-5
reconnecting all 5-25
reconnecting one 5-26

F

FICON channels 2-7

I

Inflow Control info 5-3
Inflow Control setting 4-10
interfaces 1-3
internal volume, external volume overview 1-4

L

LDEVs in mapped volumes 1-5
local system
 powering off, on 5-31
 recognizing from external system 4-13
LUN Manager 3-4

M

mainframe volumes, planning for 2-7
management LU 2-6
mapped volume, preparing to use 4-11
mapping a command device B-5
MIH 2-7
Multi path mode 2-15

P

pairs, adjusting capacity for 2-12
path errors, specific external systems 6-6
path mode 2-14
path mode, listing per system 2-16
path priority, raising and lowering 5-12
Performance Monitor 3-4
planning
 external paths 2-14
 external volumes 2-5
 mainframe external volumes 2-7
 Open system external volumes 2-8
 volume capacity 2-8
 workflow 2-2
port attributes, local system settings 4-2
port discovery, troubleshooting 6-12
ports, setup for external system 4-4
priority, raising and lowering 4-8, 5-12
Processor Blade setting 4-11
processor blade, changing 5-5
product version x

R

RAID considerations 2-3
reconnecting external path 5-14
reconnecting external systems and volumes 5-25
remote command devices B-2
restrictions, remote command devices B-3

S

Single path mode 2-14
SNMP Agent 3-5
software supported 3-1
spreadsheets 1-4
supported external systems A-1
system requirements 2-2

T

technical support 6-2
Thin Image 3-2
Thin Provisioning 3-3
Transaction Processing Facility 2-5
troubleshooting 6-2
TrueCopy 3-4

U

Universal Replicator 3-4
Universal Volume Manager
 components 1-2
 how it works 1-4
 internal, external volumes 1-4
 planning workflow 2-2
 requirements 2-2
 setup 4-2
 using spreadsheets 1-4
 volume capacity requirements 2-8

V

Virtual LUN/Virtual LVI 3-5
volume discovery, troubleshooting 6-12

W

WWN, editing settings 5-9

Hitachi Data Systems

Corporate Headquarters

2845 Lafayette Street
Santa Clara, California 95050-2639
U.S.A.

www.hds.com

Regional Contact Information

Americas

+1 408 970 1000

info@hds.com

Europe, Middle East, and Africa

+44 (0)1753 618000

info.emea@hds.com

Asia Pacific

+852 3189 7900

hds.marketing.apac@hds.com



MK-92RD8024-04